

## LED Current Controller with Line Regulation Compensation

### Description

The **XR46110** is an LED current controller with line regulation compensation for operating over a wide alternative current (AC) voltage source range. It can drive an external N-channel power MOSFET to regulate the current flowing through a high voltage (HV) LED string.

The application of the XR46110 is configured in series with an LED string, working as a constant current sink with linear type overvoltage protection (OVP), linear type over temperature protection (OTP), and line regulation compensation. It is suitable for applications with a rectified AC voltage source.

The PCB design can be very compact to meet various shape requirements. It is especially suitable for replacing incandescent light bulb and linear type fluorescent lamps.

### Typical Application

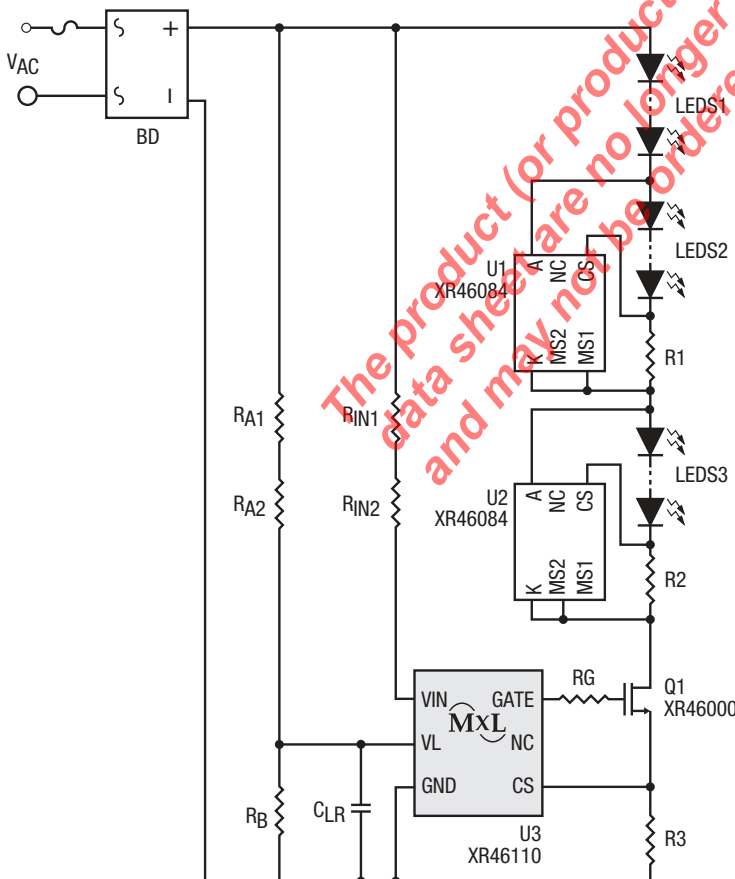

Figure 1. Typical Application

### FEATURES

- Device
  - 6V to 78V chip supply voltage range
  - Excellent system power regulation in  $\pm 10\%$  AC mains fluctuation
  - Over temperature protection
  - Overvoltage protection
  - Single board LED lighting solution available
  - 2mm x 2mm TDFN-6 package
- System
  - All solid state components
  - No electrolytic capacitor required
  - Scalable architecture allows optimization of performance vs. cost
  - Driver-on-board and chip-on-board design solution available which minimize process flow and assembly cost
  - High PF and low THD performance
  - Flexible PCB layout options

### APPLICATIONS

- LED Lighting Applications
  - Downlight
  - High bay
  - Specialty
  - Architectural

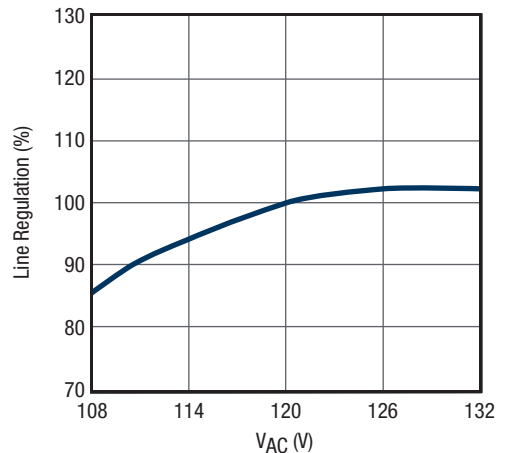

Figure 2. Line Regulation

## Absolute Maximum Ratings

Stresses beyond the limits listed below may cause permanent damage to the device. Exposure to any Absolute Maximum Rating condition for extended periods may affect device reliability and lifetime.

### Sustaining voltage

VIN, GATE to GND ..... -0.3V to 85V

GATE to CS ..... -0.3V to 7V

VL to GND..... -0.3V to 7V

CS to GND ..... -0.3V to 1V

VIN input current..... 3mA

Maximum junction temperature,  $T_J$ ..... 150°C

Storage temperature range ..... -55°C to 150°C

Lead temperature (soldering, 10 seconds)..... 260°C

ESD Rating (HBM - Human Body Model)..... 2kV

### NOTES:

1. All voltages are with respect to ground. Currents are positive into, negative out of the specified terminal.
2. All parameters having Min/Max specifications are guaranteed. Typical values are for reference purpose only.
3. Unless otherwise noted, all tests are pulsed tests at the specified temperature, therefore:  $T_J = T_C = T_A$ .

## Operating Conditions

Input voltage

VIN.....6V to  $V_{INClamp}$

Junction temperature range,  $T_J$ ..... -40°C to 125°C

**The product (or products) mentioned in this data sheet are no longer being manufactured and may not be ordered (OBS)**

## Electrical Characteristics

Unless otherwise noted, typical values are at  $T_A = 25^\circ\text{C}$ .

Symbol	Parameter	Conditions	Min	Typ	Max	Units
$V_{IN_{MIN}}$	Minimum VIN supply voltage		6			V
$I_{IN}$	VIN supply current	VIN = 6V to 73V		0.3		mA
$V_{IN_{Clamp}}$	VIN overvoltage clamp	When VIN > $V_{IN_{Clamp}}$ , $I_{IN}$ will increase to > 1mA to clamp VIN at $V_{IN_{Clamp}}$	73	76	80	V
$V_{CS}$	CS voltage	VIN = 15V and 75V, $V_{VL} = 1.75\text{V}$	244	250	256	mV
$\Delta V_{LR1}$	CS voltage line regulation vs. $V_{VL}^{(1)}$	VIN = 15V and VIN = 75V, $V_{VL} = 1.57\text{V}$ to 1.75V	-0.31	-0.28	-0.25	mV/mV
$\Delta V_{LR2}$		VIN = 15V and VIN = 75V, $V_{VL} = 1.75\text{V}$ to 2.10V	-0.27	-0.24	-0.21	
$\Delta V_{LR3}$		VIN = 15V and VIN = 75V, $V_{VL} = 2.10\text{V}$ to 2.28V	-0.33	-0.3	-0.27	
$V_{CS,Clamp}$	Maximum $V_{CS}$ clamp	VL under voltage protection, $V_{VL} < 1.45\text{V}$	310	323	336	mV
$V_{Gate}$	Gate voltage	Gate to CS		5.4		V
$I_{SOURCE}$	GATE source current <sup>(2)</sup>	$V_{Gate} - GND = 3\text{V}$ , $V_{VL} = 1.75\text{V}$ , $V_{CS} = 200\text{mV}$		40		$\mu\text{A}$
$I_{SINK}$	GATE sink current <sup>(2)</sup>	$V_{Gate} - GND = 3\text{V}$ , $V_{VL} = 1.75\text{V}$ , $V_{CS} = 500\text{mV}$		4.2		mA
$T_{TP}$	Thermal protection trip temperature <sup>(2)</sup>	When $T_J$ is higher than $T_{TP}$ , $V_{CS}$ decreases linearly	135	145		$^\circ\text{C}$
$\Delta V_{CS}/\Delta T_J$	Thermal protection mode $V_{CS}$ decreasing slope <sup>(2)</sup>	$T_J > T_{TP}$		-1.1		$\%/^\circ\text{C}$

### NOTES:

1. The CS voltage line regulation is defined as:

$$\Delta V_{LR1} = \frac{\Delta V_{CS}}{\Delta V_{VL}} = \frac{V_{CS}(V_{VL} = 1.75\text{V}) - V_{CS}(V_{VL} = 1.57\text{V})}{1.75\text{V} - 1.57\text{V}}$$

$$\Delta V_{LR2} = \frac{\Delta V_{CS}}{\Delta V_{VL}} = \frac{V_{CS}(V_{VL} = 2.10\text{V}) - V_{CS}(V_{VL} = 1.75\text{V})}{2.10\text{V} - 1.75\text{V}}$$

$$\Delta V_{LR3} = \frac{\Delta V_{CS}}{\Delta V_{VL}} = \frac{V_{CS}(V_{VL} = 2.28\text{V}) - V_{CS}(V_{VL} = 2.10\text{V})}{2.28\text{V} - 2.10\text{V}}$$

2. Guarantee by design, not by production test.

The product (or products) mentioned in this data sheet are no longer being manufactured and may not be ordered (OBS)

## Pin Configuration

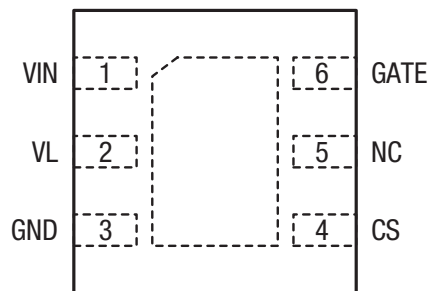

2mm x 2mm TDFN-6, Top View

## Pin Functions

Pin Number	Pin Name	Description
1	VIN	Power supply pin.
2	VL	Line regulation sense pin. The reference voltage is adjusted according to VL to provide the line regulation compensation and to provide overvoltage protection.
3	GND	Ground pin.
4	CS	Current sense pin. Connect a sense resistor, $R_{CS}$ , between this pin and the GND pin. The peak current is set by: $I_{OUT} = \frac{V_{CS}}{R_{CS}}$
5	NC	No connection.
6	GATE	External HV NMOS gate driving pin. Limited to 5.5V maximum.
Exposed Thermal Pad (EP)		Exposed thermal pad of the chip. Use this pad to enhance the power dissipation capability. The thermal conductivity will be improved if a copper foil on PCB is soldered with the thermal pad. It is recommended to connect the exposed thermal pad to the GND pin.

The product (or products) mentioned in this data sheet are no longer being manufactured and may not be ordered (OBS)

Functional Block Diagram

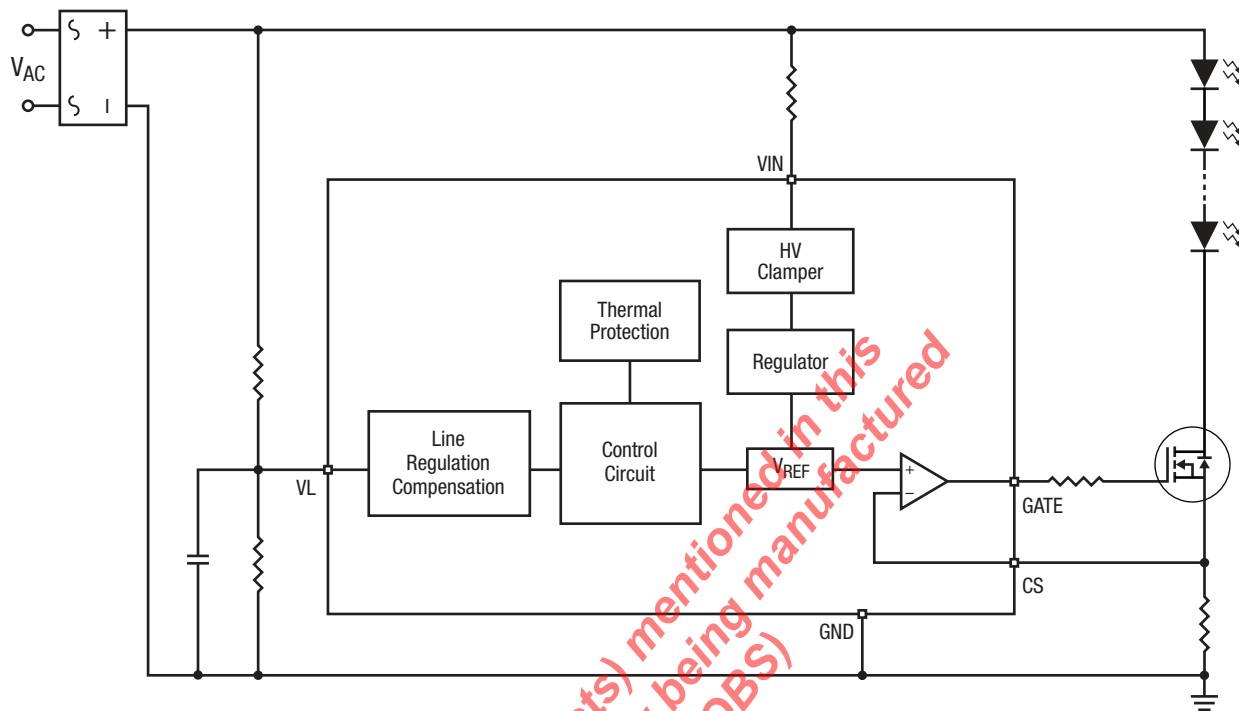

Figure 3. Functional Block Diagram

The product (or products) mentioned in this data sheet are no longer being manufactured and may not be ordered (OBS)

Applications Information

Typical Application Circuit

The XR46110 can work with XR46083 or XR46084 to support one or more steps fundamental driving structure, balance driving structure, low flicker driving structure, and phase cut dimmable driving structure. Two examples are shown in below.

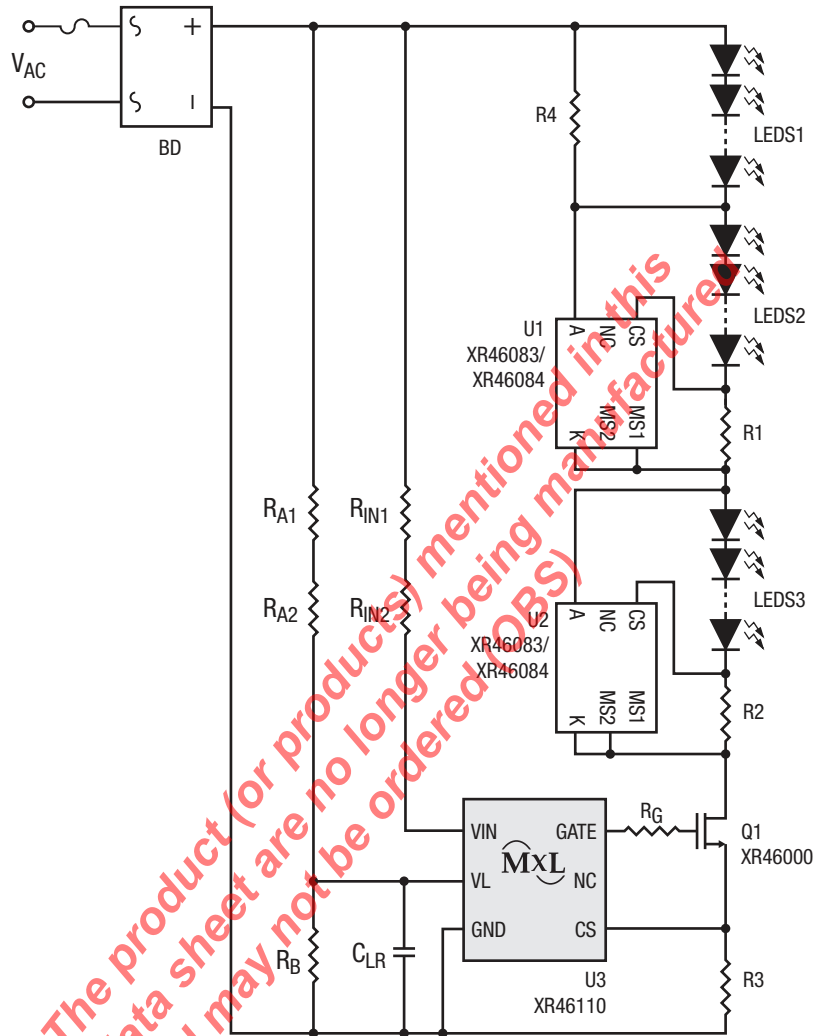

Figure 4. Fundamental 3-Step Structure

Applications Information (Continued)

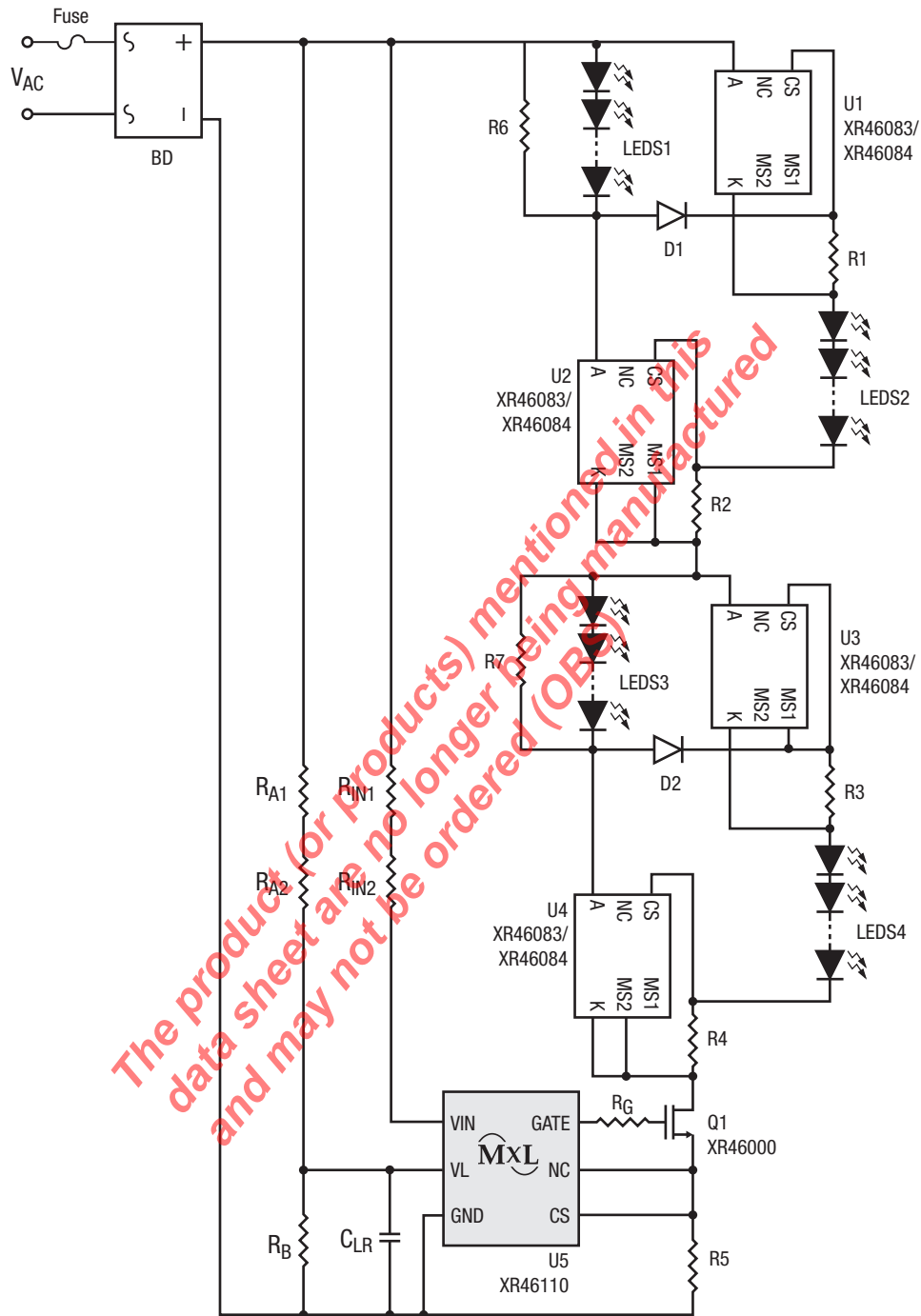

Figure 5. Balance 3-Step Structure

For a discussion regarding the basic circuit operation of MaxLinear's AC Step drivers, see XR46083 Application Notes.

## Applications Information (Continued)

### Linear Type Thermal Protection

When the junction temperature  $T_J$  rises to the Thermal Protection Trip Temperature  $T_{TP}$  (typically  $145^\circ\text{C}$ ), the current sense voltage  $V_{CS}$  starts to decrease linearly at a slope of  $-1.1\%/^\circ\text{C}$ . The LED driving current decreases proportionally with the  $V_{CS}$  voltage. The system will function normally during the thermal protection mode with the lower driving current, but the power dissipation of the system will decrease until thermal equilibrium is reached.

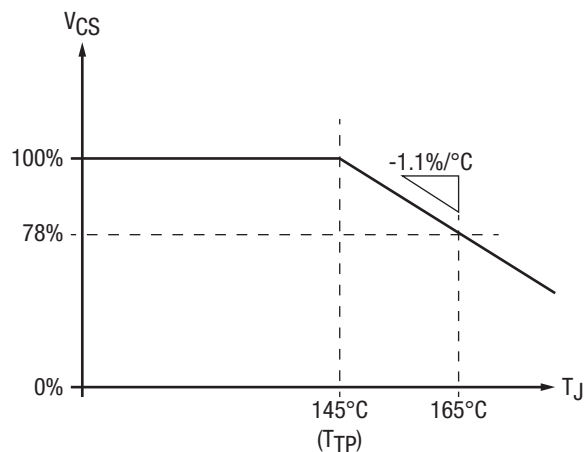

Figure 6.  $V_{CS}$  vs.  $T_J$

### Line Regulation Compensation

When there is variation in line voltage ( $V_{AC}$ ), the power of the lamp will also change if the LED driving current is kept unchanged. In order to provide good line regulation when  $V_{AC}$  varies within a  $\pm 20\%$  range, the average of the rectified  $V_{AC}$  is sensed by the VL pin to provide compensation in order to attempt to keep the power of the lamp at the same level.

The peak LED driving current is adjusted as the voltage level  $V_{VL}$  at the VL pin is changed. Based on the design, the LED driving current will be lower when  $V_{AC}$  is higher than the nominal value, and the LED driving current will be higher when  $V_{AC}$  is lower than the nominal value. The system power can then be maintained at approximately the same level. During power on, the driving current may be slightly higher for a few cycles until steady state is reached.

With the compensation function, the XR46110 provides excellent power line regulation over a  $\pm 20\%$  VAC variation range, as shown in below.

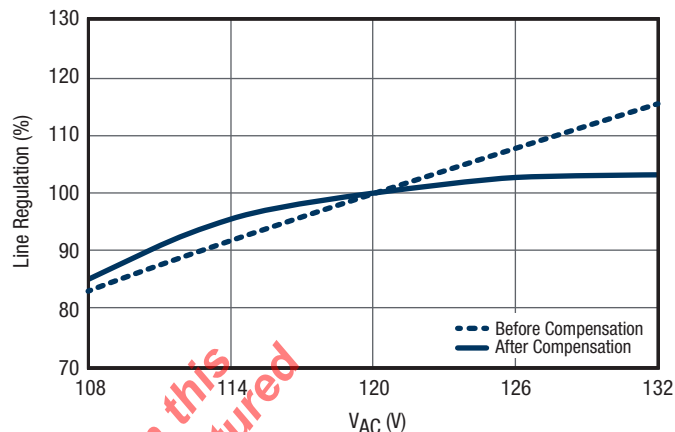

Figure 7. Power Line Regulation Compensation

### Layout Suggestion

The exposed thermal pad under the chip is used to enhance the power dissipation capability. The thermal conductivity will be improved if a copper foil on PCB soldered with the thermal pad can be as large as possible. It is strongly recommended to connect the GND pin to the exposed thermal pad.

The external HV NMOS is recommended to be placed close to the chip. The current sense resistor connected between the CS pin and GND pin should be placed as close as to the CS pin and GND pin, as the example in below.

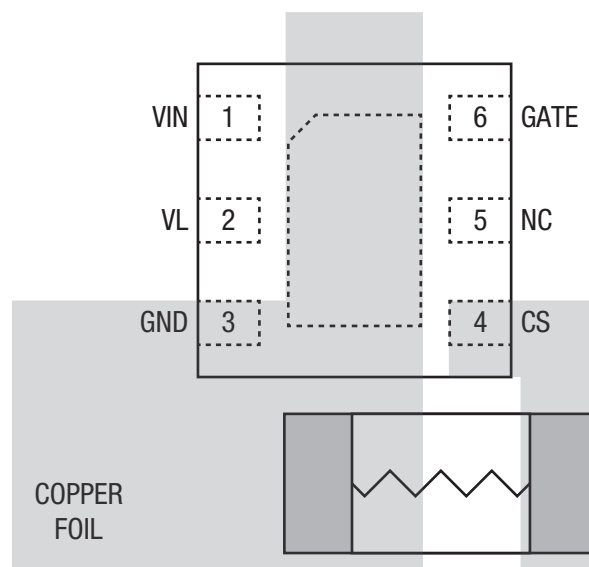
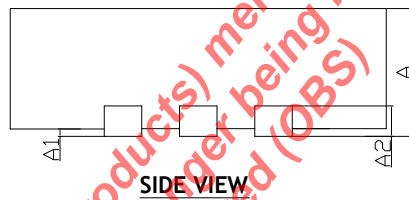
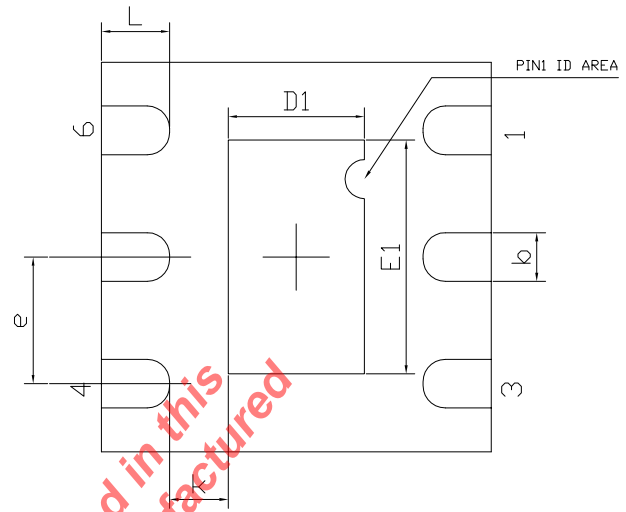
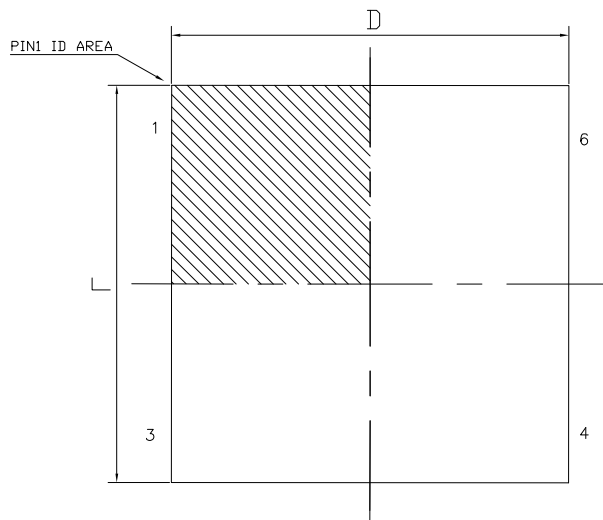

Figure 8. Layout



## Mechanical Dimensions



DIM SYMBOL	MIN	NOM	MAX
A	0.700	0.750	0.800
A1	0.000	—	0.050
A2	0.203Ref		
b	0.200	0.250	0.300
D	2.00 BSC		
E	2.00 BSC		
e	0.650 BSC		
D1	0.600	0.700	0.800
E1	1.100	1.200	1.300
L	0.274	0.350	0.426
K	0.200	—	—
N	6		

### TERMINAL DETAILS

- ALL DIMENSIONS ARE IN MILLIMETERS, ANGLES ARE IN DEGREES.
- DIMENSIONS AND TOLERANCE PER JEDEC MO-229.

Drawing No.: POD-00000072

Revision: B

Recommended Land Pattern and Stencil

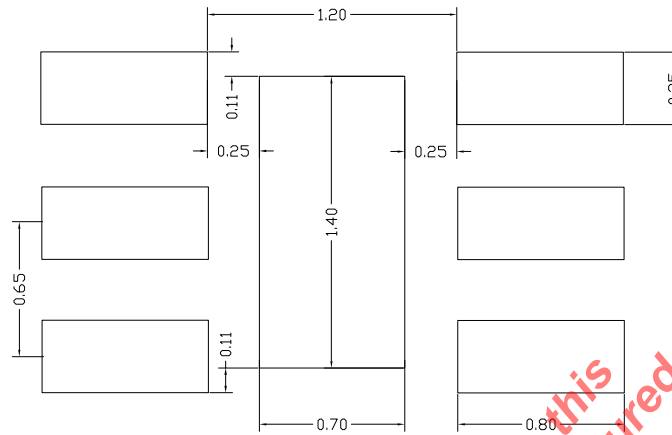

TYPICAL RECOMMENDED LAND PATTERN

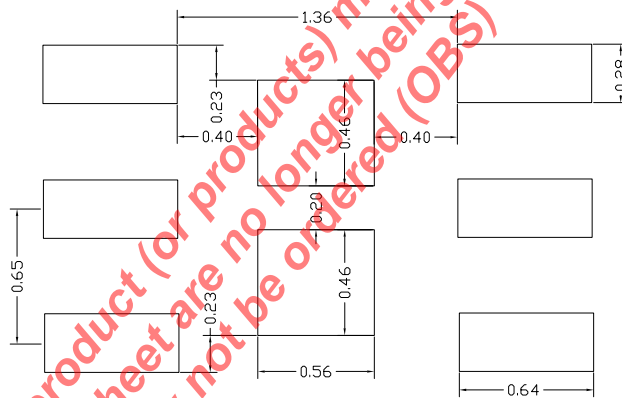

TYPICAL RECOMMENDED STENCIL

The product (or products) mentioned in this data sheet are no longer being manufactured and may not be ordered (OBS)

Drawing No.: POD-0000072

Revision: B

Ordering Information<sup>(1)</sup>

Part Number	Operating Temperature Range	Lead-Free	Package	Packaging Method
XR46110IHBTR	-40°C ≤ T <sub>J</sub> ≤ 125°C	Yes <sup>(2)</sup>	TDFN6 2x2	Tape and Reel

**NOTE:**

1. Refer to [www.exar.com/XR46110](http://www.exar.com/XR46110) for most up-to-date Ordering Information.
2. Visit [www.exar.com](http://www.exar.com) for additional information on Environmental Rating.

## Revision History

Revision	Date	Description
1.0	Jul 2015	First release.
1A	Oct 2016	Change to new datasheet format and update Package Description.
1B	Mar 2017	Add ESD, clarified operating temperature, add CS voltage line regulation min/max, update GATE source and sink current test method.
1C	Aug 2018	Update to MaxLinear logo. Update format.

The product (or products) mentioned in this data sheet are no longer being manufactured and may not be ordered (OBS)

**Corporate Headquarters:**

5966 La Place Court  
Suite 100  
Carlsbad, CA 92008  
Tel.: +1 (760) 692-0711  
Fax: +1 (760) 444-8598  
[www.maxlinear.com](http://www.maxlinear.com)

**High Performance Analog:**

1060 Rincon Circle  
San Jose, CA 95131  
Tel.: +1 (669) 265-6100  
Fax: +1 (669) 265-6101  
[www.exar.com](http://www.exar.com)

The content of this document is furnished for informational use only, is subject to change without notice, and should not be construed as a commitment by MaxLinear, Inc.. MaxLinear, Inc. assumes no responsibility or liability for any errors or inaccuracies that may appear in the informational content contained in this guide. Complying with all applicable copyright laws is the responsibility of the user. Without limiting the rights under copyright, no part of this document may be reproduced into, stored in, or introduced into a retrieval system, or transmitted in any form or by any means (electronic, mechanical, photocopying, recording, or otherwise), or for any purpose, without the express written permission of MaxLinear, Inc.

MaxLinear, Inc. does not recommend the use of any of its products in life support applications where the failure or malfunction of the product can reasonably be expected to cause failure of the life support system or to significantly affect its safety or effectiveness. Products are not authorized for use in such applications unless MaxLinear, Inc. receives, in writing, assurances to its satisfaction that: (a) the risk of injury or damage has been minimized; (b) the user assumes all such risks; (c) potential liability of MaxLinear, Inc. is adequately protected under the circumstances.

MaxLinear, Inc. may have patents, patent applications, trademarks, copyrights, or other intellectual property rights covering subject matter in this document. Except as expressly provided in any written license agreement from MaxLinear, Inc., the furnishing of this document does not give you any license to these patents, trademarks, copyrights, or other intellectual property.

Company and product names may be registered trademarks or trademarks of the respective owners with which they are associated.

© 2016 - 2018 MaxLinear, Inc. All rights reserved