

## GENERAL DESCRIPTION

The SP6669 is a synchronous current mode PWM step down (buck) converter capable of delivering up to 800mA of current. It features a pulse skip mode (PSM) for light load efficiency and a LDO mode for 100% duty cycle.

With a 2.5V to 6.0V input voltage range and a 1.5MHz switching frequency, the SP6669 allows the use of small surface mount inductors and capacitors ideal for battery powered portable applications. The internal synchronous switch increases efficiency and eliminates the need for an external Schottky diode. Low output voltages are easily supported with the 0.6V feedback reference voltage.

Built-in over temperature and output over voltage lock-out protections insure safe operations under abnormal operating conditions.

The SP6669 is offered in a RoHS compliant, "green"/halogen free 5-pin SOT23 package.

## APPLICATIONS

- **Portable Equipment**
- **Battery Operated Equipment**
- **Audio-Video Equipment**
- **Networking & Telecom Equipment**

## FEATURES

- **Guaranteed 800mA Output Current**
  - Input Voltage: 2.5V to 6.0V
- **1.5MHz PWM Current Mode Control**
  - 100% Duty Cycle LDO Mode Operations
  - Achieves 97% Efficiency
- **0.6V 2% Accurate Reference**
- **Excellent Line/Load Transient Response**
- **18µA Quiescent Current**
- **Over Temperature Protection**
- **RoHS Compliant "Green"/Halogen Free 5-Pin SOT23 Package**

## TYPICAL APPLICATION DIAGRAM

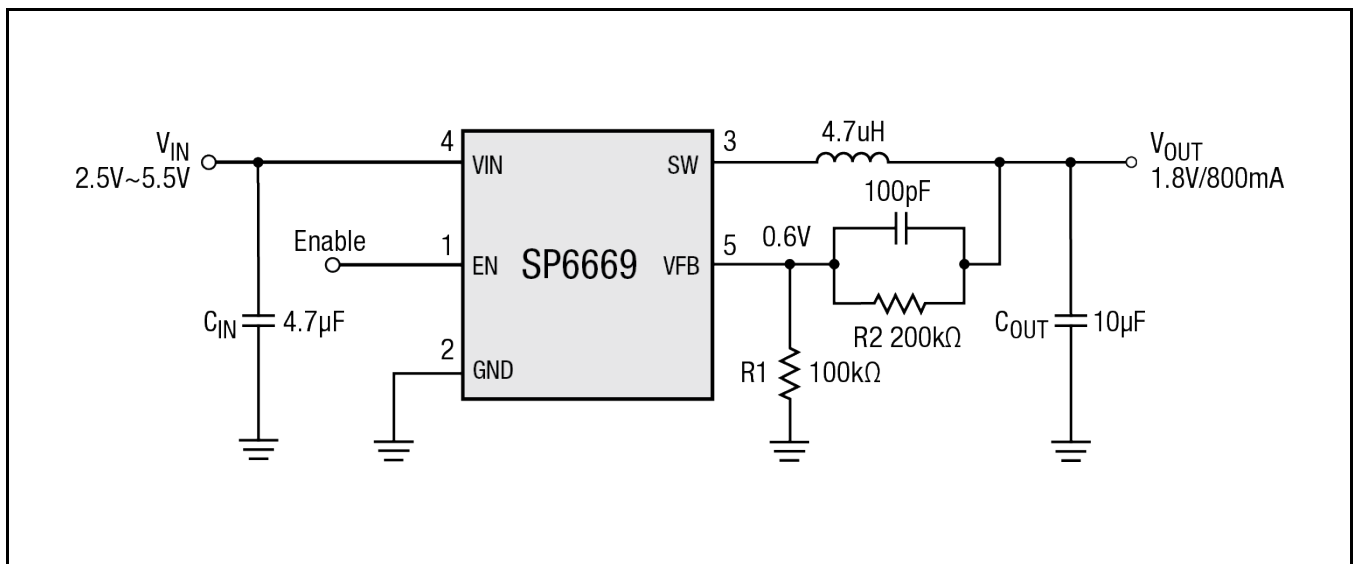

Fig. 1: SP6669 Application Diagram (Adj. version shown)

## 800mA 1.5MHz Synchronous Step Down Converter

### ABSOLUTE MAXIMUM RATINGS

These are stress ratings only and functional operation of the device at these ratings or any other above those indicated in the operation sections of the specifications below is not implied. Exposure to absolute maximum rating conditions for extended periods of time may affect reliability.

Input Voltage  $V_{IN}$ ..... -0.3V to 6.6V  
 Enable  $V_{FB}$  Voltage..... -0.3V to  $V_{IN}$   
 SW Voltage..... -0.3V to ( $V_{IN}+0.3V$ )  
 Peak Switch Sink/Source Current ..... 1.3A  
 Junction Temperature ..... 150°C  
 Storage Temperature..... -65°C to 150°C  
 Lead Temperature (Soldering, 10 sec) ..... 260°C  
 ESD Rating (HBM - Human Body Model) ..... 2kV  
 ESD Rating (CDM - Charged Device Model).....500V

### OPERATING RATINGS

Input Voltage Range  $V_{IN}$ .....2.5V to 6.0V  
 Operating Temperature Range..... -40°C to 85°C  
 Operating Junction Temperature<sup>1</sup> .....125°C  
 Thermal Resistance  $\theta_{JA}$  ..... 134.5°C/W  
 Thermal Resistance  $\theta_{JC}$ ..... 81°C/W

Note 1:  $T_J$  is a function of the ambient temperature  $T_A$  and power dissipation  $P_D$  ( $T_J = T_A + P_D \times \theta_{JA}$ ).

### ELECTRICAL SPECIFICATIONS

Specifications with standard type are for an Operating Junction Temperature of  $T_J = 25^\circ\text{C}$  only; limits applying over the full Operating Junction Temperature range are denoted by a "•". Minimum and Maximum limits are guaranteed through test, design, or statistical correlation. Typical values represent the most likely parametric norm at  $T_A = 25^\circ\text{C}$ , and are provided for reference purposes only. Unless otherwise indicated,  $V_{IN} = 3.6V$ .

Parameter	Min.	Typ.	Max.	Units	Conditions
Feedback Current $I_{VFB}$			±30	nA	
Regulated Feedback Voltage $V_{FB}$	0.588	0.600	0.612	V	•
Reference Voltage Line Regulation $\Delta V_{FB}$			0.4	%/V	• $V_{IN}=2.5V$ to 5.5V
Output Over-Voltage Lockout $\Delta V_{OVL}$	20	50	80	mV	$\Delta V_{OVL} = V_{OVL} - V_{FB}$ (Adj.)
Output Voltage Line Regulation $\Delta V_{OUT}$			0.6	%/V	• $V_{IN}=2.5V$ to 5.5V
Peak Inductor Current $I_{PK}$	1.2	2.3		A	$V_{IN}=3V$ , $V_{FB}=0.5V$
Output Voltage Load Regulation $V_{LOADREG}$		0.5		%	
Quiescent Current <sup>1</sup> $I_Q$		18		µA	$V_{FB}=0.65V$
Shutdown Current $I_{SHUTDOWN}$		0.1	1	µA	$V_{EN}=0V$ , $V_{IN}=4.2V$
Oscillator Frequency $f_{OSC}$	1.2	1.5	1.8	MHz	• $V_{FB}=0.6V$
		750		kHz	• $V_{FB}=0V$ or $V_{OUT}=0V$
RDS(ON) of PMOS $R_{PFET}$		0.24		Ω	$I_{SW}=100mA$
RDS(ON) of NMOS $R_{NFET}$		0.24		Ω	$I_{SW}=100mA$
SW Leakage $I_{LSW}$			±1	µA	$V_{EN}=0V$ , $V_{SW}=0V$ or 5V, $V_{IN}=5V$
Enable Threshold $V_{EN}$			1.2	V	•
Shutdown Threshold $V_{EN}$	0.4			V	•
EN Leakage Current $I_{EN}$			±1	µA	•

Note 1: The dynamic quiescent current is higher due to the gate charge being delivered at the switching frequency.

**BLOCK DIAGRAM**

Fig. 2: SP6669 Block Diagram

**PIN ASSIGNMENT**

Fig. 3: SP6669 Pin Assignment

**PIN DESCRIPTION**

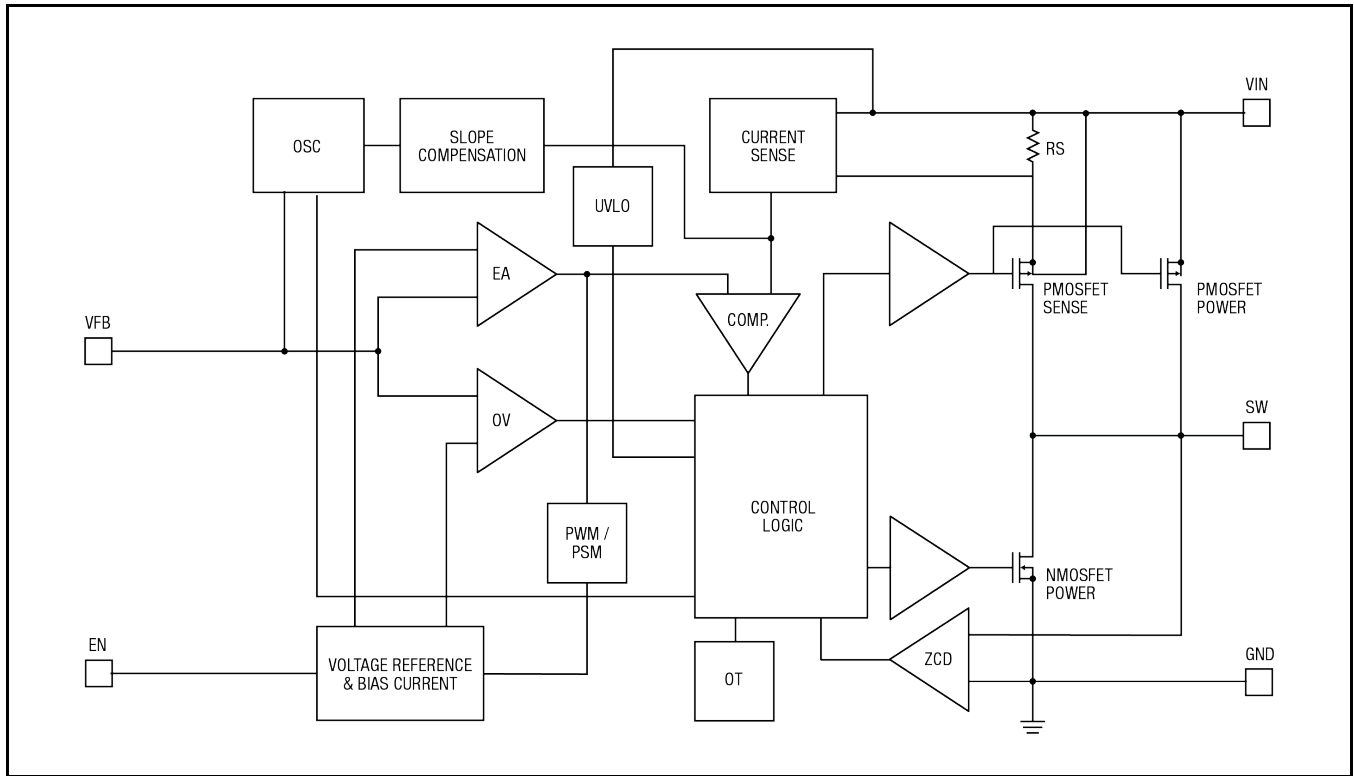
Name	Pin Number	Description
EN	1	Enable Pin. Do not leave the pin floating. $V_{EN} < 0.4V$ : Shutdown mode $V_{EN} > 1.2V$ : Device enabled
GND	2	Ground Signal
SW	3	Switching Node
VIN	4	Power Supply Pin. Must be decoupled to ground with a 4.7 $\mu$ F or greater ceramic capacitor.
VFB	5	Feedback Input Pin. Connect VFB to the center point of the resistor divider.

**ORDERING INFORMATION**

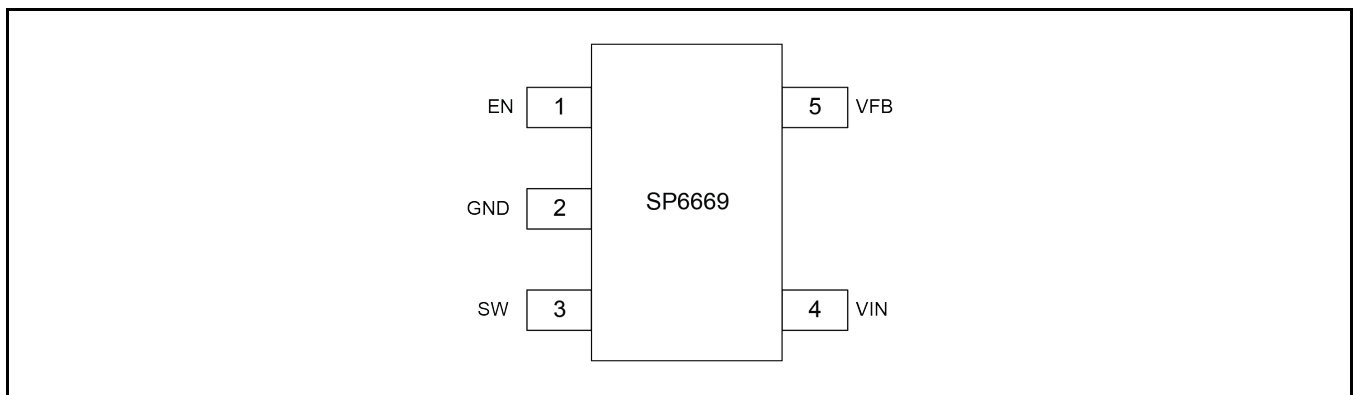
Part Number	Operating Temperature Range	Package	Packing Method	Lead-free
SP6669AEK-L/TRR3	$-40^{\circ}C \leq T_A \leq +85^{\circ}C$	SOT23-5	Tape & Reel	Yes
SP6669EB	SP6669 Evaluation Board			

Note: for most up-to-date ordering information and additional information on environmental rating, go to [www.maxlinear.com/SP6669](http://www.maxlinear.com/SP6669)

Note that the SP6669 series is packaged in Tape and Reel with a reverse part orientation as per the following diagram

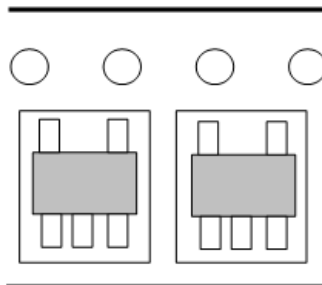

# 800mA 1.5MHz Synchronous Step Down Converter

## TYPICAL PERFORMANCE CHARACTERISTICS

All data taken at  $V_{IN} = 2.7V$  to  $5.5V$ ,  $T_J = T_A = 25^\circ C$ , unless otherwise specified - Schematic and BOM from Application Information section of this datasheet.

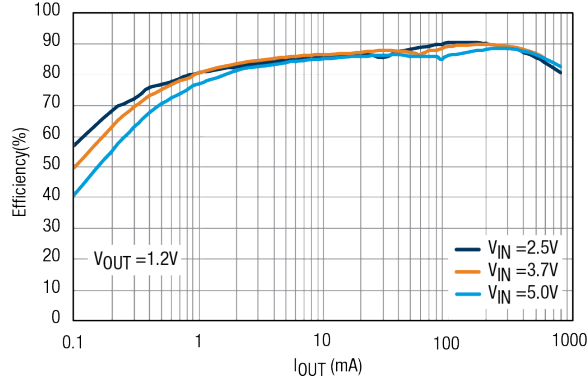

Fig. 4: Efficiency vs Output Current  $V_{OUT} = 1.2V$

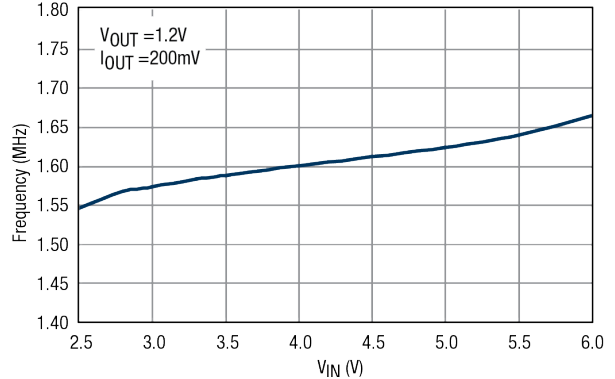

Fig. 5: Oscillator Frequency vs. Input Voltage

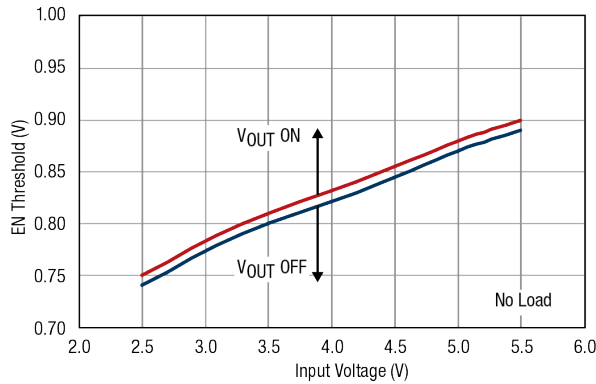

Fig. 6: EN Pin Threshold vs. Input Voltage

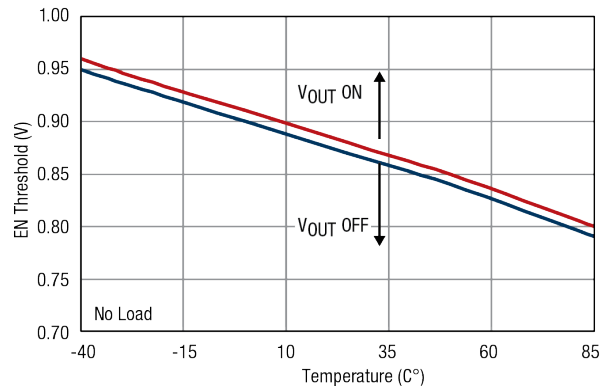

Fig. 7: EN Pin Threshold vs. Temperature

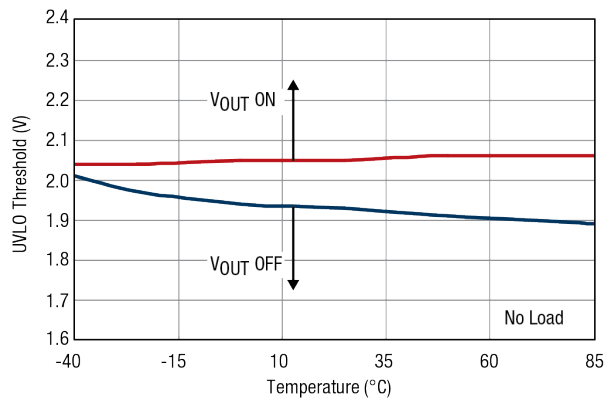

Fig. 8: UVLO Threshold vs. Temperature

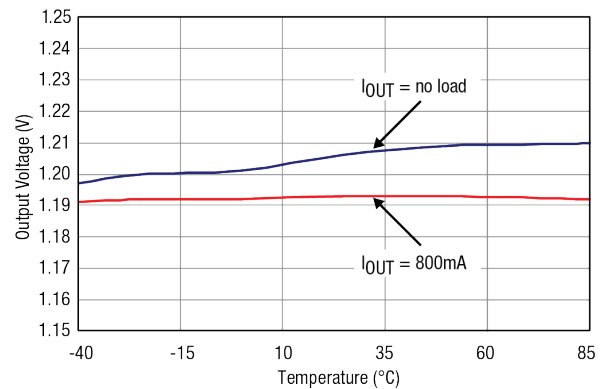

Fig. 9: Output Voltage vs Temperature

# 800mA 1.5MHz Synchronous Step Down Converter

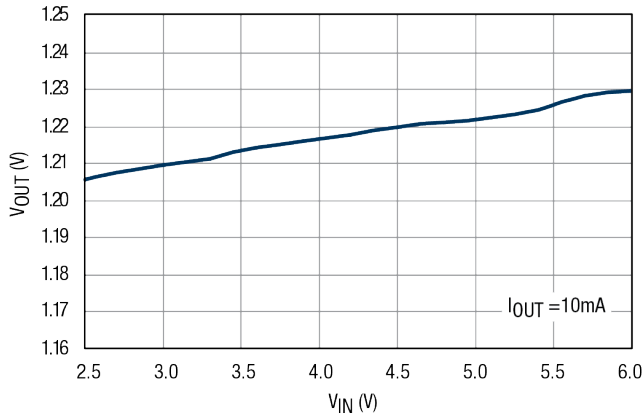

Fig. 10: Line Regulation

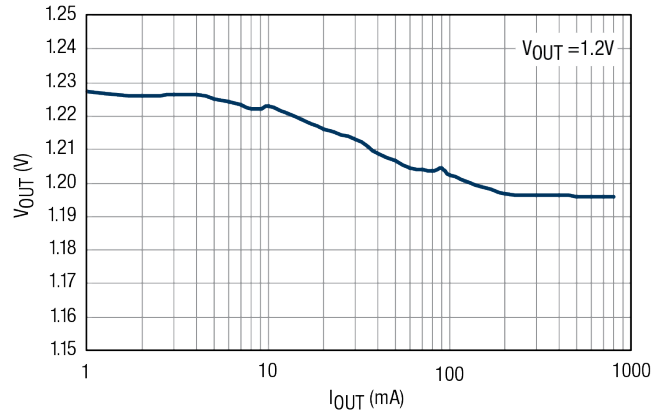

Fig. 11: Load Regulation

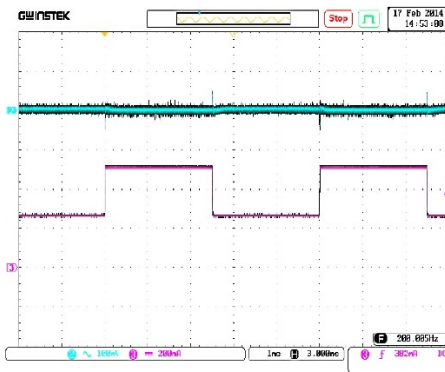

Fig. 12: Load Transient Response, Iout 250mA to 500mA, Vout = 1.2V

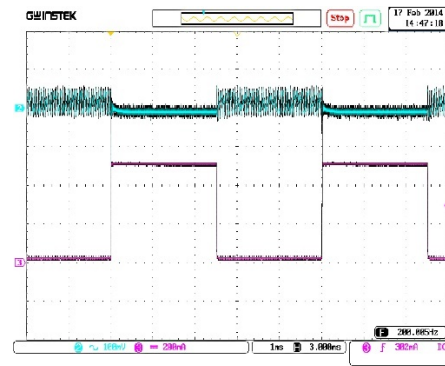

Fig. 13: Load Transient Response, Iout 10mA to 500mA, Vout = 1.2V

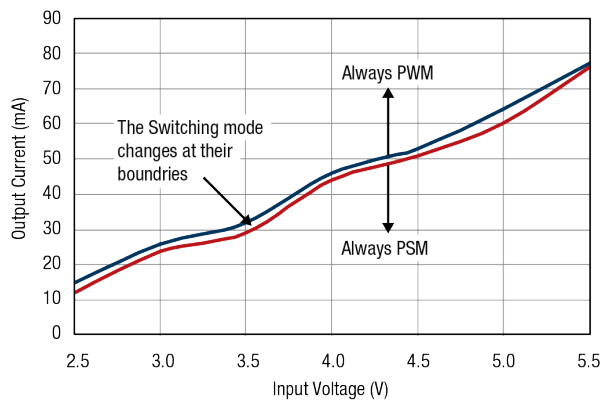

Fig. 14: PSM / PWM Boundaries

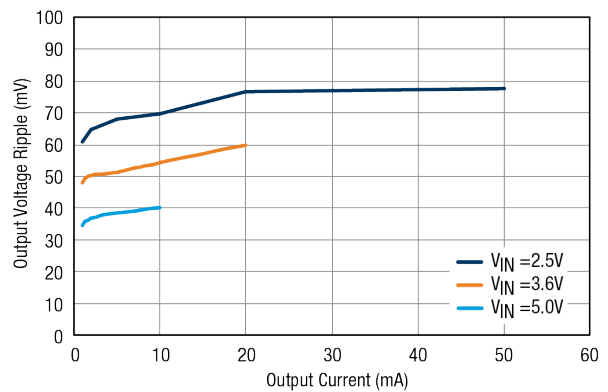

Fig. 15: Output Voltage Ripple vs Output Current

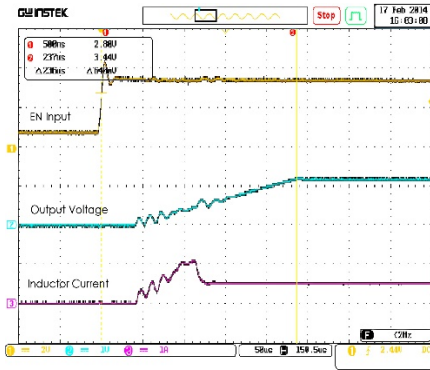

Fig. 16: Power-ON from EN Pin

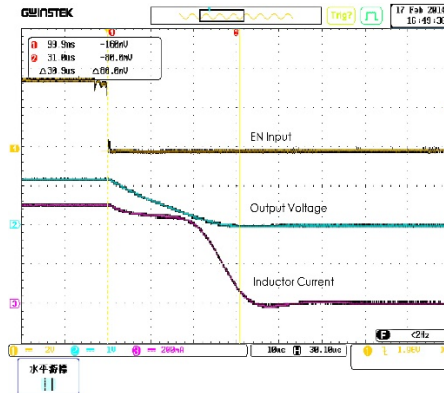

Fig. 17: Power-OFF from EN Pin

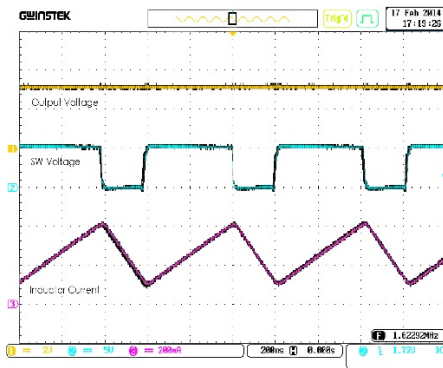

Fig. 18: PWM Operation

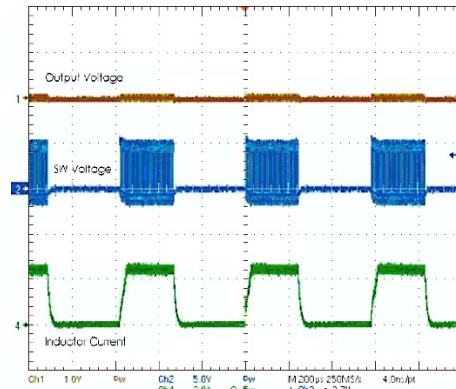

Fig. 19: Short Circuit Response

## THEORY OF OPERATION

### APPLICATIONS

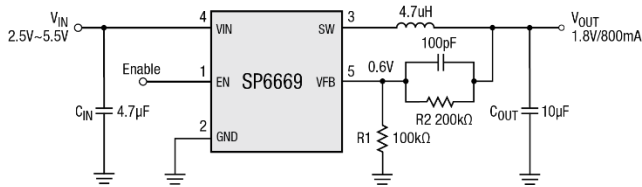

Fig. 20: Typical Application Circuit

### INDUCTOR SELECTION

Inductor ripple current and core saturation are two factors considered to select the inductor value.

$$\text{Eq. 1: } \Delta I_L = \frac{1}{f \cdot L} V_{OUT} \left( 1 - \frac{V_{OUT}}{V_{IN}} \right)$$

Equation 1 shows the inductor ripple current as a function of the frequency, inductance,  $V_{IN}$  and  $V_{OUT}$ . It is recommended to set the ripple current between 30% to 40% of the maximum load current. A low ESR inductor is preferred.

### C<sub>IN</sub> AND C<sub>OUT</sub> SELECTION

A low ESR input capacitor can prevent large voltage transients at  $V_{IN}$ . The RMS current rating of the input capacitor is required to be larger than  $I_{RMS}$  calculated by:

$$\text{Eq. 2: } I_{RMS} \cong I_{OMAX} \frac{\sqrt{V_{OUT}(V_{IN} - V_{OUT})}}{V_{IN}}$$

The ESR rating of the capacitor is an important parameter to select  $C_{OUT}$ . The output ripple  $V_{OUT}$  is determined by:

$$\text{Eq. 3: } \Delta V_{OUT} \cong \Delta I_L \left( ESR + \frac{1}{8 \cdot f \cdot C_{OUT}} \right)$$

Higher values, lower cost ceramic capacitors are now available in smaller sizes. These capacitors have high ripple currents, high voltage ratings and low ESR that makes them ideal for switching regulator applications. As  $C_{OUT}$  does not affect the internal control loop

stability, its value can be optimized to balance very low output ripple and circuit size. It is recommended to use an X5R or X7R rated capacitors which have the best temperature and voltage characteristics of all the ceramics for a given value and size.

### SETTING OUTPUT VOLTAGE

The output voltage is determined by:

$$\text{Eq. 4: } V_{OUT} = 0.6V \cdot \left( 1 + \frac{R_2}{R_1} \right)$$

### THERMAL CONSIDERATIONS

Although the SP6669 has an on board over temperature circuitry, the total power dissipation it can support is based on the package thermal capabilities. The formula to ensure safe operation is given in note 1.

### PCB LAYOUT

The following PCB layout guidelines should be taken into account to ensure proper operation and performance of the SP6669:

- 1- The GND, SW and  $V_{IN}$  traces should be kept short, direct and wide.
- 2-  $V_{FB}$  pin must be connected directly to the feedback resistors. The resistor divider network must be connected in parallel to the  $C_{OUT}$  capacitor.
- 3- The input capacitor  $C_{IN}$  must be kept as close as possible to the  $V_{IN}$  pin.
- 4- The SW and  $V_{FB}$  nodes should be kept as separate as possible to minimize possible effects from the high frequency and voltage swings of the SW node.
- 5- The ground plates of  $C_{IN}$  and  $C_{OUT}$  should be kept as close as possible.



**OUTPUT VOLTAGE RIPPLE FOR  $V_{IN}$  CLOSE TO  $V_{OUT}$** 

When the input voltage  $V_{IN}$  is close to the output voltage  $V_{OUT}$ , the SP6669 transitions smoothly from the switching PWM converter mode into a LDO mode. The following diagram shows the output voltage ripple versus the input voltage for a 3.3V output setting and a 200mA current load.

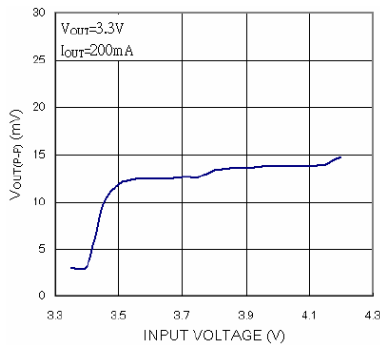

Fig. 20:  $V_{OUT}$  Ripple Voltage for  $V_{IN}$  decreasing close to  $V_{OUT}$

**DESIGN EXAMPLE**

In a single Lithium-Ion battery powered application, the  $V_{IN}$  range is about 2.7V to 4.2V. The desired output voltage is 1.8V.

The inductor value needed can be calculated using the following equation

$$L = \frac{1}{f \cdot \Delta I_L} V_{OUT} \left( 1 - \frac{V_{OUT}}{V_{IN}} \right)$$

Substituting  $V_{OUT}=1.8V$ ,  $V_{IN}=4.2V$ ,  $\Delta I_L=180mA$  to 240mA (30% to 40%) and  $f=1.3MHz$  gives

$$L = 2.86\mu H \text{ to } 3.81\mu H$$

A 3.3 $\mu H$  inductor can be chosen with this application. An inductor of greater value with less equivalent series resistance would provide better efficiency. The CIN capacitor requires an RMS current rating of at least  $I_{LOAD(MAX)}/2$  and low ESR. In most cases, a ceramic capacitor will satisfy this requirement.

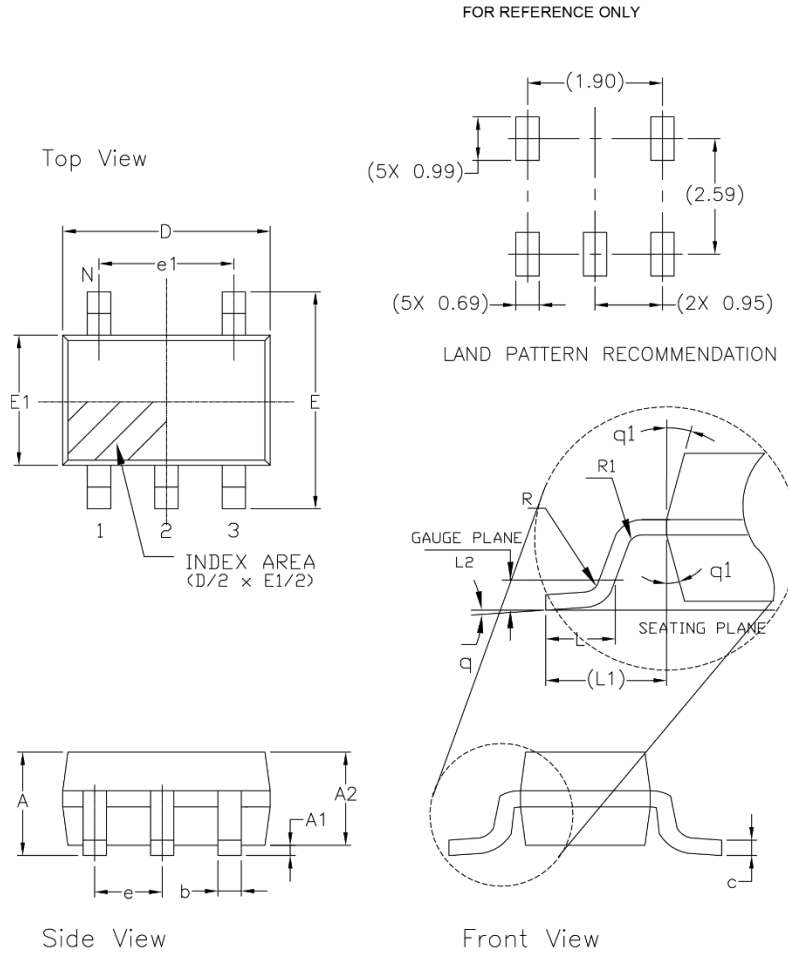
**MECHANICAL DIMENSIONS**
**5-PIN SOT23**

SYMBOLS	DIMENSIONS IN MM (Control Unit)			DIMENSIONS IN INCH (Reference Unit)		
	MIN	NOM	MAX	MIN	NOM	MAX
A	—	—	1.45	—	—	0.057
A1	0.00	—	0.15	0.000	—	0.006
A2	0.90	1.15	1.30	0.036	0.045	0.051
b	0.30	—	0.50	0.012	—	0.020
c	0.08	—	0.22	0.003	—	0.009
D	2.90 BSC			0.115 BSC		
E	2.80 BSC			0.111 BSC		
E1	1.60 BSC			0.063 BSC		
e	0.95 BSC			0.038 BSC		
e1	1.90 BSC			0.075 BSC		
L	0.30	0.45	0.60	0.012	0.018	0.024
L1	0.60 REF			0.024 REF		
L2	0.25 BSC			0.010 BSC		
R	0.10	—	—	0.004	—	—
R1	0.10	—	0.25	0.004	—	0.010
q	0°	4°	8°	0°	4°	8°
q1	5°	10°	15°	5°	10°	15°
N	5			5		

Drawing No: POD-00000025  
Revision: B

**REVISION HISTORY**

Revision	Date	Description
2.0.0	07/15/2011	Reformat of datasheet Updated package specification
2.1.0	02/07/2012	Updated Typical Application schematics and Design example
2.2.0	11/08/2012	Reformat of datasheet (New logo) Updated Absolute Maximum Ratings, Lead Temperature (Soldering, 10 sec) to 260°C
2.2.1	05/13/2016	Reformat of datasheet (New logo) Changed oscillator frequency unit
3.0.0	12/07/2017	Updated $I_{OUT}$ , $V_{IN}$ range, thermal resistance, $\Delta V_{OUT}$ , $V_{FB}$ temperature condition, $I_{PK}$ , $I_Q$ , $f_{OSC}$ , $R_{DS(ON)}$ , package drawing (now Mechanical Dimensions), format and Ordering Information. Added PSM and new graphs. Updated to MaxLinear logo. Removed fixed voltage options. New graphs.
4.0.0	01/07/2020	Updated $I_{OUT}$ , $V_{IN}$ range and $V_{IN}$ absolute max, $I_Q$ , $I_{PK}$ , $R_{DS(ON)}$ . Updated graphs. Updated ESD rating.
5.0.0	07/26/2021	Updated $I_{OUT}$ , $V_{IN}$ range and $V_{IN}$ absolute max, $I_Q$ , $I_{PK}$ , $R_{DS(ON)}$ . Updated graphs. Updated ESD rating. PCN 19011A (Addendum) cancels rev 4.0.0, therefore rev 5.0.0 is the same as rev 3.0.0.

**Corporate Headquarters:**

5966 La Place Court  
Suite 100  
Carlsbad, CA 92008  
Tel.: +1 (760) 692-0711  
Fax: +1 (760) 444-8598  
[www.maxlinear.com](http://www.maxlinear.com)

The content of this document is furnished for informational use only, is subject to change without notice, and should not be construed as a commitment by MaxLinear, Inc.. MaxLinear, Inc. assumes no responsibility or liability for any errors or inaccuracies that may appear in the informational content contained in this guide. Complying with all applicable copyright laws is the responsibility of the user. Without limiting the rights under copyright, no part of this document may be reproduced into, stored in, or introduced into a retrieval system, or transmitted in any form or by any means (electronic, mechanical, photocopying, recording, or otherwise), or for any purpose, without the express written permission of MaxLinear, Inc.

MaxLinear, Inc. does not recommend the use of any of its products in life support applications where the failure or malfunction of the product can reasonably be expected to cause failure of the life support system or to significantly affect its safety or effectiveness. Products are not authorized for use in such applications unless MaxLinear, Inc. receives, in writing, assurances to its satisfaction that: (a) the risk of injury or damage has been minimized; (b) the user assumes all such risks; (c) potential liability of MaxLinear, Inc. is adequately protected under the circumstances.

MaxLinear, Inc. may have patents, patent applications, trademarks, copyrights, or other intellectual property rights covering subject matter in this document. Except as expressly provided in any written license agreement from MaxLinear, Inc., the furnishing of this document does not give you any license to these patents, trademarks, copyrights, or other intellectual property.

MaxLinear, the MaxLinear logo, any MaxLinear trademarks (MxL, Full-Spectrum Capture, FSC, G.now, AirPHY, Puma, and AnyWAN), and the MaxLinear logo on the products sold are all property of MaxLinear, Inc. or one of MaxLinear's subsidiaries in the U.S.A. and other countries. All rights reserved. Other company trademarks and product names appearing herein are the property of their respective owners.

© 2021 MaxLinear, Inc. All rights reserved.