



# GSW125

Ethernet Switch

## 4-Port Gigabit Ethernet Switch with 2 Integrated Gigabit Ethernet PHYs

GSW125 (GSW125-AQM-T)

## Data Sheet

Revision 1.3, 2023-01-19  
Reference ID 620247

## Legal Notice

The content of this document is furnished for informational use only, is subject to change without notice, and should not be construed as a commitment by MaxLinear, Inc. MaxLinear, Inc. assumes no responsibility or liability for any errors or inaccuracies that may appear in the informational content contained in this guide. Complying with all applicable copyright laws is the responsibility of the user. Without limiting the rights under copyright, no part of this document may be reproduced into, stored in, or introduced into a retrieval system, or transmitted in any form or by any means (electronic, mechanical, photocopying, recording, or otherwise), or for any purpose, without the express written permission of MaxLinear, Inc.

MaxLinear, Inc. does not recommend the use of any of its products in life support applications where the failure or malfunction of the product can reasonably be expected to cause failure of the life support system or to significantly affect its safety or effectiveness. Products are not authorized for use in such applications unless MaxLinear, Inc. receives, in writing, assurances to its satisfaction that: (a) the risk of injury or damage has been minimized; (b) the user assumes all such risks; (c) potential liability of MaxLinear, Inc. is adequately protected under the circumstances.

MaxLinear, Inc. may have patents, patent applications, trademarks, copyrights, or other intellectual property rights covering subject matter in this document. Except as expressly provided in any written license agreement from MaxLinear, Inc., the furnishing of this document does not give you any license to these patents, trademarks, copyrights, or other intellectual property.

MaxLinear, the MaxLinear logo, any MaxLinear trademarks (MxL, Full-Spectrum Capture, FSC, G.now, AirPHY, Puma, and AnyWAN), and the MaxLinear logo on the products sold are all property of MaxLinear, Inc. or one of MaxLinear's subsidiaries in the U.S.A. and other countries. All rights reserved.

\*Other company trademarks and product names appearing herein are the property of their respective owners.

© 2023 MaxLinear, Inc. All rights reserved.

MaxLinear, Inc.  
5966 La Place Court, Suite 100  
Carlsbad, CA 92008  
Tel.: +1 (760) 692-0711  
Fax: +1 (760) 444-8598  
[www.maxlinear.com](http://www.maxlinear.com)

## Revision History

**Current:** Revision 1.3, 2023-01-19

**Previous:** Revision 1.2, 2022-04-01

| Page | Major changes since previous revision  |
|------|--|
| 1    | Updated the Cover Page.  |
| 13   | Updated <a href="#">Section 1.1, Features</a> .  |
| 20   | Updated <a href="#">Section 1.3, Block Diagram</a> .   |
| 25   | Updated <a href="#">Table 5, Ethernet Media Independent Interface Signals</a> .              |
| 27   | Updated <a href="#">Table 6, LED Interface Signals</a> .                                     |
| 32   | Updated <a href="#">Table 9, Power Supply Pins</a> .   |
| 42   | Updated <a href="#">Section 3.2.5, SPI Slave Access</a> .                                    |
| 68   | Added <a href="#">Section 3.6.3, RMI Configuration</a> .                                     |
| 138  | Updated <a href="#">xMII Interface 5 Configuration Register</a> .                            |
| 215  | Removed external PHY interrupts from <a href="#">IM0 Interrupt Status Register</a> .         |
| 215  | Removed external PHY interrupts from <a href="#">IM0 EINT0 Interrupt Enable Register</a> .   |
| 216  | Removed external PHY interrupts from <a href="#">IM0 EINT1 Interrupt Enable Register</a> .   |
| 274  | Updated <a href="#">PHYID2</a> reset value in <a href="#">Table 60, Registers Overview</a> . |
| 274  | Updated reset value in the <a href="#">PHY Identifier 2</a> register.                        |
| 334  | Added <a href="#">Section 5.5.7, RMI Interface Timing Characteristics</a> .                  |
|      |  |

## Table of Contents

|          |   |    |
|----------|---|----|
|          | <b>Table of Contents</b> .....                          | 4  |
|          | <b>List of Figures</b> .....                            | 8  |
|          | <b>List of Tables</b> .....                             | 10 |
| <b>1</b> | <b>Product Overview</b> .....                           | 12 |
| 1.1      | Features .....  | 13 |
| 1.2      | Applications .....                                      | 17 |
| 1.3      | Block Diagram .....                                     | 20 |
| <b>2</b> | <b>External Signals</b> .....                           | 21 |
| 2.1      | Logic Symbol .....                                      | 21 |
| 2.2      | External Signal Description .....                       | 22 |
| 2.2.1    | Pin Diagram .....                                       | 22 |
| 2.2.2    | Abbreviations .....                                     | 23 |
| 2.2.3    | Input/Output Signals .....                              | 24 |
| 2.2.3.1  | Ethernet Media Interface .....                          | 24 |
| 2.2.3.2  | SGMII Interface .....                                   | 25 |
| 2.2.3.3  | Ethernet Media Independent Interface .....              | 25 |
| 2.2.3.4  | LED/UART/JTAG Interface .....                           | 26 |
| 2.2.3.5  | Management Interfaces .....                             | 29 |
| 2.2.3.6  | Miscellaneous Signals .....                             | 31 |
| 2.2.3.7  | Power Supply .....                                      | 32 |
| <b>3</b> | <b>Functional Description</b> .....                     | 33 |
| 3.1      | Clock and Reset .....                                   | 33 |
| 3.1.1    | Clock Generation Unit .....                             | 33 |
| 3.1.2    | General Purpose Clock Output .....                      | 33 |
| 3.1.3    | Reset Generation Unit .....                             | 33 |
| 3.1.4    | Power Up Sequence .....                                 | 33 |
| 3.2      | Management Interface Functional Description .....       | 34 |
| 3.2.1    | Management Interface Subsystem Features .....           | 34 |
| 3.2.2    | MDIO Master Module .....                                | 35 |
| 3.2.3    | MDIO Slave Module .....                                 | 38 |
| 3.2.4    | SPI Master Module .....                                 | 41 |
| 3.2.5    | SPI Slave Access .....                                  | 42 |
| 3.2.6    | UART Access .....                                       | 43 |
| 3.2.7    | Boot Loader Description .....                           | 44 |
| 3.2.8    | Packet Insertion and Extraction .....                   | 55 |
| 3.3      | LED Controller Function Description .....               | 57 |
| 3.3.1    | LED .....   | 57 |
| 3.3.2    | LED Display .....                                       | 57 |
| 3.3.3    | LED Brightness Control .....                            | 59 |
| 3.4      | General Purpose Input Output Function Description ..... | 61 |
| 3.5      | Gigabit Ethernet PHY Functional Description .....       | 63 |
| 3.5.1    | Features .....  | 63 |
| 3.5.2    | Functional Description .....                            | 63 |
| 3.5.2.1  | Twisted-Pair Interface .....                            | 63 |
| 3.5.2.2  | Auto-Negotiation (ANEG) .....                           | 64 |
| 3.5.2.3  | Auto-Downspeed .....                                    | 64 |
| 3.5.2.4  | Auto-Crossover and Polarity-Reversal Correction .....   | 65 |

|           |  |    |
|-----------|--|----|
| 3.5.2.5   | Transformerless Ethernet (TLE)                   | 65 |
| 3.5.2.6   | Configuration and Control via MDIO               | 66 |
| 3.5.2.7   | Power Management                                 | 66 |
| 3.5.2.7.1 | Power Down Modes                                 | 66 |
| 3.5.2.7.2 | Sleep Mode                                       | 66 |
| 3.5.2.7.3 | Scan Mode  | 66 |
| 3.5.2.7.4 | Ping Mode  | 66 |
| 3.5.2.7.5 | Normal Mode                                      | 67 |
| 3.5.2.7.6 | Low-Power Idle Mode: Energy-Efficient Ethernet   | 67 |
| 3.6       | Reduced Media-Independent Interface              | 68 |
| 3.6.1     | Features   | 68 |
| 3.6.2     | Functional Description                           | 68 |
| 3.6.3     | RMII Configuration                               | 68 |
| 3.7       | SGMII Interface Function Description             | 69 |
| 3.7.1     | Features   | 69 |
| 3.7.2     | Functional Description                           | 69 |
| 3.7.2.1   | Typical Applications                             | 69 |
| 3.7.2.1.1 | Interface to an External MAC                     | 69 |
| 3.7.2.1.2 | Interface to an External 1000BASE-T Ethernet PHY | 69 |
| 3.7.2.1.3 | Interface to an External 1000BASE-X Ethernet PHY | 70 |
| 3.7.2.2   | Modes of Operation                               | 70 |
| 3.7.2.3   | Test Features, Status and Enabling               | 71 |
| 3.7.2.3.1 | PMA/PMD Loops                                    | 71 |
| 3.7.2.3.2 | PCS Loops  | 71 |
| 3.8       | Switch Fabric Functional Description             | 72 |
| 3.8.1     | Overview   | 72 |
| 3.8.2     | Ethernet Bridging                                | 73 |
| 3.8.2.1   | Parsing  | 73 |
| 3.8.2.2   | MAC Bridging Table                               | 73 |
| 3.8.2.3   | MAC Based Forwarding                             | 74 |
| 3.8.2.4   | Dynamic Source MAC Address Learning and Aging    | 74 |
| 3.8.2.5   | Layer 2 Security                                 | 76 |
| 3.8.2.6   | Spanning Tree Protocol Support                   | 78 |
| 3.8.2.7   | Reserved MAC Addresses                           | 78 |
| 3.8.2.8   | Flow Control Function                            | 79 |
| 3.8.2.9   | Port Trunking Functions                          | 79 |
| 3.8.2.10  | Gigabit Media Access Control (GMAC) Functions    | 80 |
| 3.8.3     | VLAN Functions                                   | 82 |
| 3.8.3.1   | VLAN Association                                 | 82 |
| 3.8.3.2   | VLAN QinQ  | 82 |
| 3.8.3.3   | Supported Frame Format                           | 83 |
| 3.8.3.4   | Double VLAN Tag Function                         | 83 |
| 3.8.3.5   | Filtering Identifier Assignment                  | 83 |
| 3.8.3.6   | VLAN Filtering                                   | 84 |
| 3.8.3.7   | VLAN Tagging and Untagging                       | 85 |
| 3.8.3.8   | Transparent VLAN Mode                            | 85 |
| 3.8.3.9   | VLAN Security Mode                               | 86 |
| 3.8.3.10  | Reserved VLAN Groups                             | 86 |
| 3.8.3.11  | VLAN Translation                                 | 87 |
| 3.8.3.12  | VLAN Priority Code Point                         | 87 |
| 3.8.3.13  | Port Based VLAN Examples                         | 88 |

|          |  |            |
|----------|--|------------|
| 3.8.3.14 | Single Tag Based VLAN Examples                         | 88         |
| 3.8.3.15 | Double Tag Based VLAN Examples                         | 89         |
| 3.8.4    | Multicast Forwarding Functions                         | 91         |
| 3.8.4.1  | Layer-2 Multicast Forwarding                           | 92         |
| 3.8.4.2  | Layer-3 Multicast Forwarding                           | 92         |
| 3.8.4.3  | IGMP and MLD Snooping                                  | 92         |
| 3.8.5    | Quality of Service Functions                           | 96         |
| 3.8.5.1  | Class of Service Assignment                            | 96         |
| 3.8.5.2  | Remarking Function                                     | 98         |
| 3.8.5.3  | Queue Mapping  | 104        |
| 3.8.5.4  | Rate Metering  | 104        |
| 3.8.5.5  | Rate Shaping   | 106        |
| 3.8.5.6  | Queue Scheduling                                       | 107        |
| 3.8.5.7  | Congestion Management                                  | 107        |
| 3.8.5.8  | Ingress Port Congestion Based Flow Control             | 108        |
| 3.8.5.9  | Overview of the Resource Protection Mechanism          | 109        |
| 3.8.5.10 | Storm Control  | 111        |
| 3.8.6    | Flow Classification Function                           | 112        |
| 3.8.7    | Operation, Administration, and Management Functions    | 115        |
| 3.8.7.1  | Monitoring Counters                                    | 115        |
| 3.8.7.2  | Port Mirroring   | 119        |
| 3.8.7.3  | Wake-on-LAN Functionality                              | 120        |
| 3.8.7.4  | Time Stamp Functionality                               | 121        |
| 3.8.7.5  | Special Tag Functionality                              | 122        |
| <b>4</b> | <b>Registers</b>                                       | <b>127</b> |
| 4.1      | Top Level PDI Registers                                | 127        |
| 4.1.1    | GPHY Shell Registers                                   | 131        |
| 4.1.2    | R(G)MII Registers                                      | 138        |
| 4.1.3    | MDIO Master Registers                                  | 150        |
| 4.1.4    | MDIO Slave Registers                                   | 167        |
| 4.1.5    | SPI Master Registers                                   | 169        |
| 4.1.6    | SPI Slave Registers                                    | 178        |
| 4.1.7    | UART Registers   | 179        |
| 4.1.8    | Clock Generation Unit Registers                        | 183        |
| 4.1.9    | Reset Control Unit Registers                           | 197        |
| 4.1.10   | GPIO Registers   | 207        |
| 4.1.11   | ICU Registers  | 215        |
| 4.1.12   | LED Registers  | 219        |
| 4.2      | SGMII_Registers  | 223        |
| 4.2.1    | SGMII_TBI: TBI Submodule Register File                 | 226        |
| 4.2.2    | SGMII_PCS: SGMII PCS Register File                     | 243        |
| 4.2.3    | SGMII_PHY: SGMII_PHY Registers                         | 250        |
| 4.2.4    | SGMII_MACRO_REGISTERS: SGMII_MACRO Registers           | 265        |
| 4.3      | PHY MDIO Registers                                     | 268        |
| 4.3.1    | STD: Standard Management Registers                     | 270        |
| 4.3.2    | PHY: PHY-Specific Management Registers                 | 288        |
| 4.4      | PHY MMD Registers                                      | 306        |
| 4.4.1    | PMAPMD: Standard PMAPMD Registers for MMD=0x01         | 308        |
| 4.4.2    | EEE: Standard EEE Registers for MMD=0x03               | 309        |
| 4.4.3    | ANEG: Standard Auto-Negotiation Registers for MMD=0x07 | 312        |
| 4.4.4    | INTERNAL: Internal Address Space (MMD=0x1F)            | 314        |

|           |  |     |
|-----------|--|-----|
| <b>5</b>  | <b>Electrical Characteristics</b>            | 325 |
| 5.1       | Absolute Maximum Ratings                     | 325 |
| 5.2       | Operating Range                              | 326 |
| 5.3       | Power Consumption                            | 327 |
| 5.4       | DC Characteristics                           | 328 |
| 5.4.1     | Digital Interfaces                           | 328 |
| 5.4.1.1   | GPIO Interfaces                              | 328 |
| 5.4.1.2   | RGMIITransmit Interface                      | 328 |
| 5.4.1.3   | RGMIIReceive Interface                       | 329 |
| 5.5       | AC Characteristics                           | 330 |
| 5.5.1     | Reset  | 330 |
| 5.5.2     | Power Supply                                 | 331 |
| 5.5.3     | Input Clock                                  | 331 |
| 5.5.4     | Output Clock                                 | 331 |
| 5.5.5     | MDIO Interface                               | 332 |
| 5.5.6     | SMDIO Interface                              | 333 |
| 5.5.7     | RMII Interface Timing Characteristics        | 334 |
| 5.5.8     | RGMIITiming Characteristics                  | 335 |
| 5.5.8.1   | RGMIITransmit Interface                      | 335 |
| 5.5.8.2   | SGMIITransmit Interface                      | 336 |
| 5.5.8.2.1 | Transmit Timing Characteristics              | 336 |
| 5.5.8.2.2 | Receive Timing Characteristics               | 337 |
| 5.5.9     | Test Interface                               | 338 |
| 5.5.10    | Crystal Specification                        | 339 |
| 5.5.11    | Transformers (Magnetics)                     | 339 |
| <b>6</b>  | <b>Package Outline</b>                       | 341 |
| 6.1       | PG-MRQFN-105 Package                         | 341 |
| 6.2       | Chip Identification and Ordering Information | 343 |
|           | <b>Standards References</b>                  | 344 |

## List of Figures

|           |   |     |
|-----------|---|-----|
| Figure 1  | Standalone Desktop Switch with an Optional Brightness Sensor . . . . .          | 17  |
| Figure 2  | Standalone Desktop Switch with an Optional Brightness Control Switch . . . . .  | 18  |
| Figure 3  | Home Gateway . . . . .  | 19  |
| Figure 4  | Block Diagram . . . . .   | 20  |
| Figure 5  | GSW125 Logic Symbol . . . . .   | 21  |
| Figure 6  | Pin Layout . . . . .  | 22  |
| Figure 7  | Auto-polling FSM - Port Loop . . . . .  | 36  |
| Figure 8  | Auto Polling FSM - Main Loop . . . . .  | 37  |
| Figure 9  | MDIO Proxy in Switching Mode . . . . .  | 39  |
| Figure 10 | SPI Slave Access . . . . .  | 42  |
| Figure 11 | LED Display Mode . . . . .  | 57  |
| Figure 12 | Pin Strapping on Dual Color LED . . . . .                                       | 58  |
| Figure 13 | Pin Strapping on Single Color LED . . . . .                                     | 58  |
| Figure 14 | LED Brightness Control By Controlling LED Output Enable/Disable . . . . .       | 59  |
| Figure 15 | Direct 2 Level LED Control Enable on System Board (with Pull-Up) . . . . .      | 60  |
| Figure 16 | Light Sensing System . . . . .  | 61  |
| Figure 17 | General Port Structure . . . . .  | 62  |
| Figure 18 | Twisted-Pair Interface of GPHY IP Including Transformer and RJ45 Plug . . . . . | 64  |
| Figure 19 | External Circuitry for the Transformerless Ethernet Application . . . . .       | 65  |
| Figure 20 | State Diagram for Power-Down Mode Management . . . . .                          | 66  |
| Figure 21 | EEE Low-Power Idle Sequence . . . . .   | 67  |
| Figure 22 | Test Loops in the GSW125 . . . . .  | 71  |
| Figure 23 | Packet Flow Diagram . . . . .   | 72  |
| Figure 24 | MAC Bridge Table Entry Formats . . . . .  | 74  |
| Figure 25 | Port Trunking Function . . . . .  | 79  |
| Figure 26 | Supported Frame Formats when STAG is enabled . . . . .                          | 83  |
| Figure 27 | Supported Frame Formats when STAG is disabled . . . . .                         | 83  |
| Figure 28 | Port-based VLAN Example . . . . .   | 88  |
| Figure 29 | Tag-based VLAN Example . . . . .  | 89  |
| Figure 30 | Double Tag and Port based VLAN Example . . . . .                                | 90  |
| Figure 31 | Traffic Class Assignment . . . . .  | 97  |
| Figure 32 | PCP/DSCP /DEI Remarking . . . . .   | 98  |
| Figure 33 | DSCP Remarking Flow Diagram . . . . .   | 99  |
| Figure 34 | Drop Precedence Remarking Flow Diagram . . . . .                                | 100 |
| Figure 35 | STAG PCP Remarking Flow Diagram . . . . .                                       | 101 |
| Figure 36 | STAG DEI Remarking Flow Diagram . . . . .                                       | 102 |
| Figure 37 | CTAG PCP Remarking Flow Diagram . . . . .                                       | 103 |
| Figure 38 | Metering Algorithm . . . . .  | 105 |
| Figure 39 | Drop Precedence Thresholds . . . . .  | 108 |
| Figure 40 | Traffic Flow Table . . . . .  | 112 |
| Figure 41 | Port Mirroring Examples – Ingress Monitoring . . . . .                          | 119 |
| Figure 42 | Port Mirroring Examples – Egress Monitoring . . . . .                           | 119 |
| Figure 43 | Typical Magic Packet Data Structure . . . . .                                   | 120 |
| Figure 44 | Magic Packet Data Structure – Password Protection . . . . .                     | 121 |
| Figure 45 | Time Stamp Event Location in the Frame . . . . .                                | 121 |
| Figure 46 | Special Tag Location in the Frame . . . . .                                     | 122 |
| Figure 47 | Timing Diagram for the GSW125 Reset Sequence . . . . .                          | 330 |
| Figure 48 | Timing Diagram for the MDIO Interface . . . . .                                 | 332 |
| Figure 49 | Timing Diagram for the SMDIO Interface . . . . .                                | 333 |



---

**List of Figures**

|           |   |     |
|-----------|---|-----|
| Figure 50 | Transmit/Receive Timing Diagram of the RMII.....                            | 334 |
| Figure 51 | Timing Diagram of the RGMII.....  | 335 |
| Figure 52 | Transmit Timing Diagram of the SGMII (Shows Alternating Data Sequence)..... | 336 |
| Figure 53 | Receive Timing Diagram of the SGMII (Alternating Data Input Sequence).....  | 337 |
| Figure 54 | Test Interface Timing.....  | 338 |
| Figure 55 | Schematic of a Transformer with CMC on Line.....                            | 339 |
| Figure 56 | Schematic of a Transformer with CMC on PHY Side.....                        | 340 |
| Figure 57 | MRQFN 8 mm x 8 mm Package Outline.....                                      | 341 |
| Figure 58 | MRQFN 8 mm x 8 mm Package Dimensions.....                                   | 342 |
| Figure 59 | Example of Chip Marking.....  | 343 |

## List of Tables

|          |   |     |
|----------|---|-----|
| Table 1  | Abbreviations for Pin Type  | 23  |
| Table 2  | Abbreviations for Buffer Type   | 23  |
| Table 3  | Ethernet Media Interface Signals  | 24  |
| Table 4  | SGMII Interface Signals   | 25  |
| Table 5  | Ethernet Media Independent Interface Signals                                      | 25  |
| Table 6  | LED Interface Signals   | 26  |
| Table 7  | Management Interface Signals  | 29  |
| Table 8  | Miscellaneous Signals   | 31  |
| Table 9  | Power Supply Pins   | 32  |
| Table 10 | Default Master MDIO Address Assignment  | 35  |
| Table 11 | Registers Configuration for Self-start Mode: Standalone Unmanaged Switch Sub-Mode | 44  |
| Table 12 | Registers Configuration for Self-start Mode: Managed Switch Sub-Mode              | 46  |
| Table 13 | LED Status VS LED Mode  | 48  |
| Table 14 | EEPROM Type Record  | 49  |
| Table 15 | Configuration Content Record: Incremental Access Format                           | 50  |
| Table 16 | Configuration Content Record: Single Access without Write Enable Format           | 50  |
| Table 17 | Configuration Content Record: Single Write Access with Write Enable Format        | 51  |
| Table 18 | Configuration Content Record: Run Self-start Mode Configuration Format            | 52  |
| Table 19 | Configuration Content Record: Wait Until True Format                              | 52  |
| Table 20 | Configuration Content Record: Conditional Jump Access Format                      | 52  |
| Table 21 | EEPROM Content Format   | 53  |
| Table 22 | Functional Mode Pin Strapping   | 53  |
| Table 23 | Pin Strapping Description   | 54  |
| Table 24 | SUBTYPE Mode Configuration  | 54  |
| Table 25 | Bit Rates   | 70  |
| Table 26 | MAC Learning Disable and MAC Learning Limitation Description                      | 77  |
| Table 27 | Port Settings   | 89  |
| Table 28 | CTAG VLAN Membership Table  | 89  |
| Table 29 | Traffic Flow Table  | 89  |
| Table 30 | Multicast Forwarding Decision   | 91  |
| Table 31 | Multicast Host Messages   | 93  |
| Table 32 | Multicast Router Messages   | 93  |
| Table 33 | Typical IGMP/MLD Control Packets Forwarding Destination                           | 94  |
| Table 34 | IGMP/MLD Messages   | 95  |
| Table 35 | Typical IGMP/MLD Messages Forwarding Destination                                  | 95  |
| Table 36 | Resource Protection Options   | 110 |
| Table 37 | Standard RMON Counters  | 115 |
| Table 38 | Special Tag Ingress Format  | 122 |
| Table 39 | Port Map Coding   | 123 |
| Table 40 | Traffic Class Map Coding  | 123 |
| Table 41 | Special Tag Egress External Format (with Ethertype)                               | 124 |
| Table 42 | Special Tag Egress Internal Format (without Ethertype)                            | 125 |
| Table 43 | Error Codes   | 126 |
| Table 44 | Registers Overview  | 127 |
| Table 45 | Register Access Types   | 130 |
| Table 46 | Similar Registers   | 131 |
| Table 47 | Similar Registers   | 132 |
| Table 48 | Similar Registers   | 133 |
| Table 49 | Similar Registers   | 134 |

**List of Tables**

|          |   |     |
|----------|---|-----|
| Table 50 | Similar Registers   | 135 |
| Table 51 | Similar Registers   | 136 |
| Table 52 | Similar Registers   | 137 |
| Table 53 | Similar Registers   | 160 |
| Table 54 | Similar Registers   | 166 |
| Table 55 | Similar Registers   | 192 |
| Table 56 | Registers Address Space   | 223 |
| Table 57 | Registers Overview  | 223 |
| Table 58 | Register Access Types   | 225 |
| Table 59 | Registers Address Space   | 268 |
| Table 60 | Registers Overview  | 268 |
| Table 61 | Register Access Types   | 269 |
| Table 62 | Registers Address Space   | 306 |
| Table 63 | Registers Overview  | 306 |
| Table 64 | Register Access Types   | 307 |
| Table 65 | Similar Registers   | 318 |
| Table 66 | Similar Registers   | 319 |
| Table 67 | Similar Registers   | 322 |
| Table 68 | Similar Registers   | 323 |
| Table 69 | Absolute Limit Ratings  | 325 |
| Table 70 | Operating Range   | 326 |
| Table 71 | Power Consumption   | 327 |
| Table 72 | DC Characteristics of the GPIO Interfaces (VDDP=3.3V)             | 328 |
| Table 73 | DC Characteristics of the Transmit RGMII Interface                | 328 |
| Table 74 | DC Characteristics of the Receive RGMII Interface                 | 329 |
| Table 75 | AC Characteristics of the HRSTN Pin                               | 330 |
| Table 76 | AC Characteristics of the Power Supply                            | 331 |
| Table 77 | AC Characteristics of Input Clock on XTAL1 pin                    | 331 |
| Table 78 | AC Characteristics of Output Clock on GPC pin                     | 331 |
| Table 79 | Timing Characteristics of the MDIO Interface                      | 332 |
| Table 80 | Timing Characteristics of the SMDIO Interface                     | 333 |
| Table 81 | Timing Characteristics of the RMII at 100 Mbit/s                  | 334 |
| Table 82 | Timing Characteristics of the RGMII                               | 336 |
| Table 83 | Transmit Timing Characteristics of the SGMII                      | 337 |
| Table 84 | Receive Timing Characteristics of the SGMII                       | 337 |
| Table 85 | Test Interface Clock  | 338 |
| Table 86 | JTAG Timing   | 338 |
| Table 87 | Specification of the Crystal                                      | 339 |
| Table 88 | Electrical Characteristics for Supported Transformers (Magnetics) | 340 |
| Table 89 | JEDEC Thermal Resistance PG-MRQFN-105 Package Parameters          | 341 |
| Table 90 | Chip Marking Pattern  | 343 |
| Table 91 | Product Naming  | 343 |

## 1 Product Overview

MaxLinear's Ethernet Switch GSW125 is a highly integrated, low-power, non-blocking four-port Gigabit Ethernet Switch with two tri-speed Ethernet PHYs, one four-speed SGMII interface, and one tri-speed RGMII interface. Switch ports 2 and 3 are unused. GSW125 uses a very small package, 8 mm x 8 mm, to minimize PCB size. There is one package variant available. For package details, see [Package Outline](#).

Each Gigabit Ethernet (GbE) PHY supports 10BASE-Te, 100BASE-TX, and 1000BASE-T standards and is characterized by low power consumption. Support of Energy-Efficient Ethernet allows for even further reduction in idle mode power consumption. Power saving at the system level is also possible with the Wake-on-LAN feature. A low-EMI line driver with integrated termination facilitates a simplified PCB design.

The 5th port of the GSW125 supports a four-speed (10/100/1000/2500 Mbps) SGMII interface to connect to an external PHY, SFP stick, or the MAC of an external chip.

The 6th port of the GSW125 supports a tri-speed (10/100/1000 Mbps) RGMII interface to connect to an external PHY or the MAC of an external chip.

The GSW125 is configurable via pin strapping, MDIO interface, UART interface, SPI interface, or optionally by connecting an external EEPROM.

In addition, the 7th 802.3 Gigabit Ethernet MAC is integrated for packet insertion and extraction. This allows an external controller to transmit and receive Ethernet packets via the management interface.

The GSW125 supports up to three LEDs per GbE PHY. Smart LED brightness control logic is integrated for power saving. LED brightness is either adjusted by a push button or varies dynamically depending on the intensity of the light measured by an external light sensor.

The 128 KB embedded packet storage SRAM is integrated and 9 KB jumbo frames are supported. The GSW125 integrates a 4K entry VLAN table for 802.1Q port-based, tag-based, and protocol based VLAN operation. It also supports double VLAN tagging, insertion, removal, and translation. The GSW125 features 2048 MAC addresses with 4-way hashing algorithm for address searching, auto-learning, and auto-aging.

Programmable parsing and a powerful classification engine allow future-proof designs that enable various data traffic types. The GSW125 supports IPv4 and IPv6 multicast forwarding, including IGMPv1/v2/v3 and MLD v1/v2 snooping.

The GSW125 features an advanced QoS architecture which prioritizes switch traffic for different classes of applications based on multiple fields of the packet. Multiple queues per port with strict or weighted round robin scheduling and rate shaping are supported. VLAN PCP and IP DSCP can be remarked. The GSW125 also supports Precise Time Stamping indication according to IEEE 1588v2 and IEEE 802.1AS.

Several degrees of application complexity are covered, from a basic stand-alone switch and set-top boxes to complex home gateways. The GSW125 is intended for Video/Audio applications in the Digital Home such as IP-TV, ADSL2+/VDSL2/PON IAD, Gateway, Wireless Router, Cable, Storage and HomePlug AV applications.

## 1.1 Features

This section provides an overview of the basic Gigabit Ethernet Switch GSW125 functionality.

### Interfaces

- Two multiple speed Ethernet PHY interfaces, compliant with:
  - 10BASE-Te
  - 100BASE-TX
  - 1000BASE-T
  - Auto-MDIX
  - Auto-Downspeed
  - Auto-Negotiation with Next Page Support
  - Cable Diagnostics: Cable Open/Short Detection and Cable length estimation
  - Test Loops and Analog Self Test
  - Power Down Modes
  - 802.3az Energy-Efficient Ethernet
  - Support of Transformer-Less Ethernet for Backplane Applications
- One set of RGMII interface:
  - 10 Mbps, full and half duplex
  - 100 Mbps, full and half duplex
  - 1000 Mbps, full duplex
- One set of RMII interface:
  - RMII interface
    - 100 Mbps, full and half duplex
- One set of SGMII Interface:
  - Cisco\* Serial-GMII Specification Rev 1.8 standard compliant operation at 1.25 Gbaud/s; extensions to achieve 3.125 Gbaud/s by overclocking
  - 2.5 Gbps (one lane of XAUI conforming per 802.3, part 4, clause 47: 10 Gigabit Attachment Unit Interface (XAUI)) full duplex
  - SerDes interface includes Clock and Data Recovery (CDR)
  - Multiple power-down modes
  - Programmable TX attenuation and amplification
  - Programmable flat-band RX equalization
  - Auto-calibration of RX and TX impedances
  - Test loop feature for debugging
    - 10 Mbps, full and half duplex
    - 100 Mbps, full and half duplex
    - 1000 Mbps, full duplex
    - 2500 Mbps, full duplex
- MDIO master interface to control external devices:
  - Support auto polling of external PHY devices registers
  - Support indirect access by command to external devices registers:
    - Support programmable MDC clock up to 17 MHz
- SPI master interface connecting to a serial external E2PROM:
  - Support programmable SPI clock up to 42 MHz
  - Supports automatic switch configuration from an external E2PROM memory
  - Support write access to E2PROM by an external controller
  - Supports different E2PROM sizes from 1 kbits to 1024 kbits
- SPI Slave, MDIO slave or UART interface to allow control from an external microcontroller:
  - Maximum MDIO interface clock: 25 MHz
  - Maximum SPI interface clock: 12.5 MHz

- UART baud rate from 4800 to 921600
- JTAG boundary scan, test and debug interface
  - Share pins with LED
- PHY status indicating LEDs:
  - Directly attached
  - Up to three LEDs per internal PHY port
  - Configurable LED functions per LED (link/activity, duplex/collision, link speed etc)
  - Steady/blinking indication
  - LED brightness controlled by an external push button
  - Up to 16 level LED brightness controlled by an external light sensor
- Twenty five general purpose IO: share pins with MDIO master interface, external interrupts, general purpose clock, SPI master interface, SPI slave interface, UART interface, MDIO slave, LED, JTAG functions.

### **Clocking**

- Reference clock:
  - 25 MHz or 40 MHz
  - Crystal or direct input
- Two external clock outputs

### **Ethernet MACs**

- Seven Ethernet MACs, complying with IEEE 802.3:
  - Four rates, that is, 10 Mbps, 100 Mbps, 1000 Mbps and 2500 Mbps operation speed
  - Half-duplex operation mode for 10 Mbps and 100 Mbps
  - Full-duplex operation mode for all speed
  - One dedicated Ethernet MAC is for packet insertion and extraction by an external controller via management interface
- Auto-negotiation for speed, duplex, flow control support, LPI support and link status
- Enhanced frame size support (“Jumbo frames”, programmable limit up to 9 Kbyte)
- Flow control:
  - Pause frame transmission/reception in full duplex mode
  - Forced collisions in half-duplex mode

### **Layer-2 Switching**

- Store-and-forward architecture
- 1 Mbit on-chip segmented frame buffer
- 256 byte buffer segment size
- Up to 2048 MAC addresses:
  - Multiple-bucket HASH algorithm storage
  - Automatic learning and aging (1 s to 24 h)
  - Manual learning (static entries)
  - MAC learning limitation (configurable per port)
  - MAC port locking and spoofing detection (configurable per port)
  - MAC table freezing
- VLAN-unaware switching
- VLAN-aware switching:
  - Shared VLAN learning
  - Independent VLAN learning
  - Up to 4096 VLAN IDs
  - Port based VLAN
  - MAC based VLAN with automatic learning

- Protocol-based VLAN based on flow classification result
- Double VLAN or VLAN QinQ, addition/removal/translation of Service Tag VLAN ID and Customer Tag VLAN ID
- Double VLAN or VLAN QinQ, port filtering based on both Service Tag VLAN ID and Customer Tag VLAN ID
- Multicast
  - Up to 64 multicast groups
  - Hardware IGMP mode: hardware based Join/Leave for IGMPv1/IGMPv2 mode, report suppression support
  - Software IGMP mode: IGMPv1/v2/v3 and MLDv1/v2 Snooping
  - Unknown IP multicast data stream forwarding or discard
  - Any Source Multicast and Source Specific Multicast forwarding

### **Layer-2/3/4 Flow Classification**

- Multi-field parsing and classification, for example based on:
  - MAC source address
  - MAC destination address
  - Service Tag VLAN ID and Customer Tag VLAN ID
  - Ethertype
  - IPv4 header (DSCP, IP SA, IP DA)
  - IPv6 header (DSCP, IP SA, IP DA)
  - TCP source port/port range
  - TCP destination port/port range
  - UDP source port/port range
  - UDP destination port/port range
  - IGMP
  - MLD
  - ARP/RARP
  - ICMP
  - PPPoE, up to 16 session IDs
  - 64 ACL rules

### **Quality of Service**

- Up to 32 CoS (Class of Service) queues
- Configurable egress queue scheduling
  - Strict priority
  - Weighted fair queuing, with configurable weights
  - Combination of strict priority and weighted fair queuing
- Flexible assignment of queues to egress ports
  - Multiple queues can be assigned to a single port (as far as available from the global pool of queues)
  - Maximum 16 queues per port
- Scalable egress rate shaping
  - 32 rate shapers
  - Up to 2 rate shapers can be assigned to a single queue (as far as available from global pool of rate shapers)
- Ingress traffic policing
  - 16 traffic policers
  - Standard single-rate Three Color Marker algorithm (srTCM)
  - Color-aware/-unaware operation
  - Policer can be assigned based on ingress port, egress port and flow classification result
  - Remarking, Drop or Flow Control for non-conforming traffic
- Flexible QoS handling based on any flow classification result, for example (but not limited to)
  - Service TAG VLAN PCP (Priority Code Point)
  - Customer TAG VLAN PCP (Priority Code Point)

- IP DSCP
- Ingress port
- Source/destination IP address
- TCP/UDP port/port range
- Service Tag VLAN PCP and DEI remarking
- Customer Tag VLAN PCP remarking
- DSCP remarking
- Congestion management
  - WRED algorithm (Weighted Random Early Discard)
  - Buffer reservation
  - Ingress port congestion based flow control
  - Ingress port metering based flow control
  - Three drop precedences
  - Configurable thresholds
- AVB support
  - Supports Precise Time Stamping indication according to IEEE P802.3bf for support of IEEE 1588v2, and IEEE 802.1AS
  - Rate shaper can work either at Token Bucket Mode or Credit Based Mode

**Security**

- Access Control List (ACL)
  - Use L2/L3/L4 flow classification results
  - Blacklist
  - Whitelist
- Access control actions
  - Accept
  - Discard
  - Redirect
  - Port Filtering
  - Cross-state forwarding
  - Cross-VLAN forwarding
  - QoS classification
  - VLAN Service Tag VLAN ID and Custom VLAN ID translation
- Broadcast, unknown multicast and unknown unicast storm control
- Authentication support (IEEE 802.1X Port Authentication)

**Other Features**

- Spanning Tree/Rapid Spanning Tree and 16 STP instances per port
- Port trunking of any two ports
- Port mirroring
- 802.3az Energy-Efficient Ethernet
- Wake-on-LAN
  - Detection of “magic packets”
  - Check WoL password (optional)
  - Wake-up interrupt to external device
- Special Tag
  - Provides in-band packet control and status communication with an internal or external controller
- RMON counters
- Boundary Scan



## Power Supply

- Supply voltage domains
  - 3.3 V for digital PAD except RGMII PAD
  - 3.3 V for analog GPHY and SerDes
  - 1.1 V for digital core
  - 1.1 V for analog GPHY and SerDes
  - 3.3 V or 2.5 V for digital RGMII PAD

## 1.2 Applications

The following figures show application examples.

**Figure 1** and **Figure 2** show standalone switch applications with a SFP port. The main advantage for the SFP port is the flexibility for putting it in the network. SFP stands for "small form-factor pluggable" and is a hot-swappable input/output device that plugs into a Gigabit Ethernet port or slot, linking the port with the network. An optional external EEPROM is used for switch configuration. **Figure 1** shows an optional low cost brightness sensor integrated to allow the LED brightness to be controlled by the Gigabit Ethernet Switch to save the system power consumption. **Figure 2** shows an optional brightness on/off switch integrated to allow the LED brightness to be controlled by the switch button to save the system power consumption.

**Figure 3** shows an application of home gateway. An external SoC can manage the switch via management interface (eg. UART, SPI or MDIO interface). The 2.5 Gbps SGMII interface allows the high throughput rate between Ethernet LAN ports and SoC. In addition, another LAN/WAN type interface can be build (for example MoCA, Wi-Fi, Ethernet etc) and connected to the router/gateway SoC via a RGMII interface.

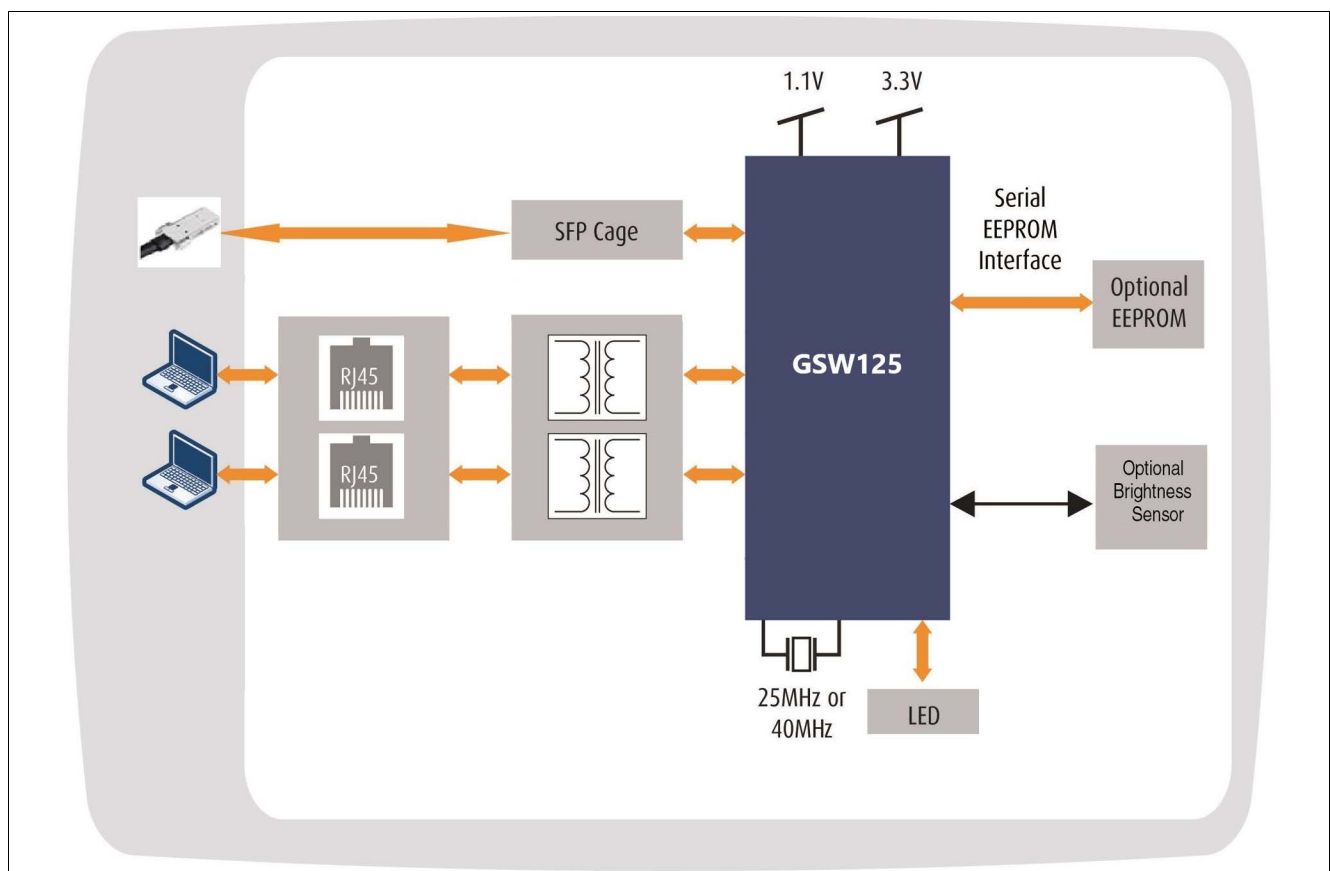

**Figure 1 Standalone Desktop Switch with an Optional Brightness Sensor**

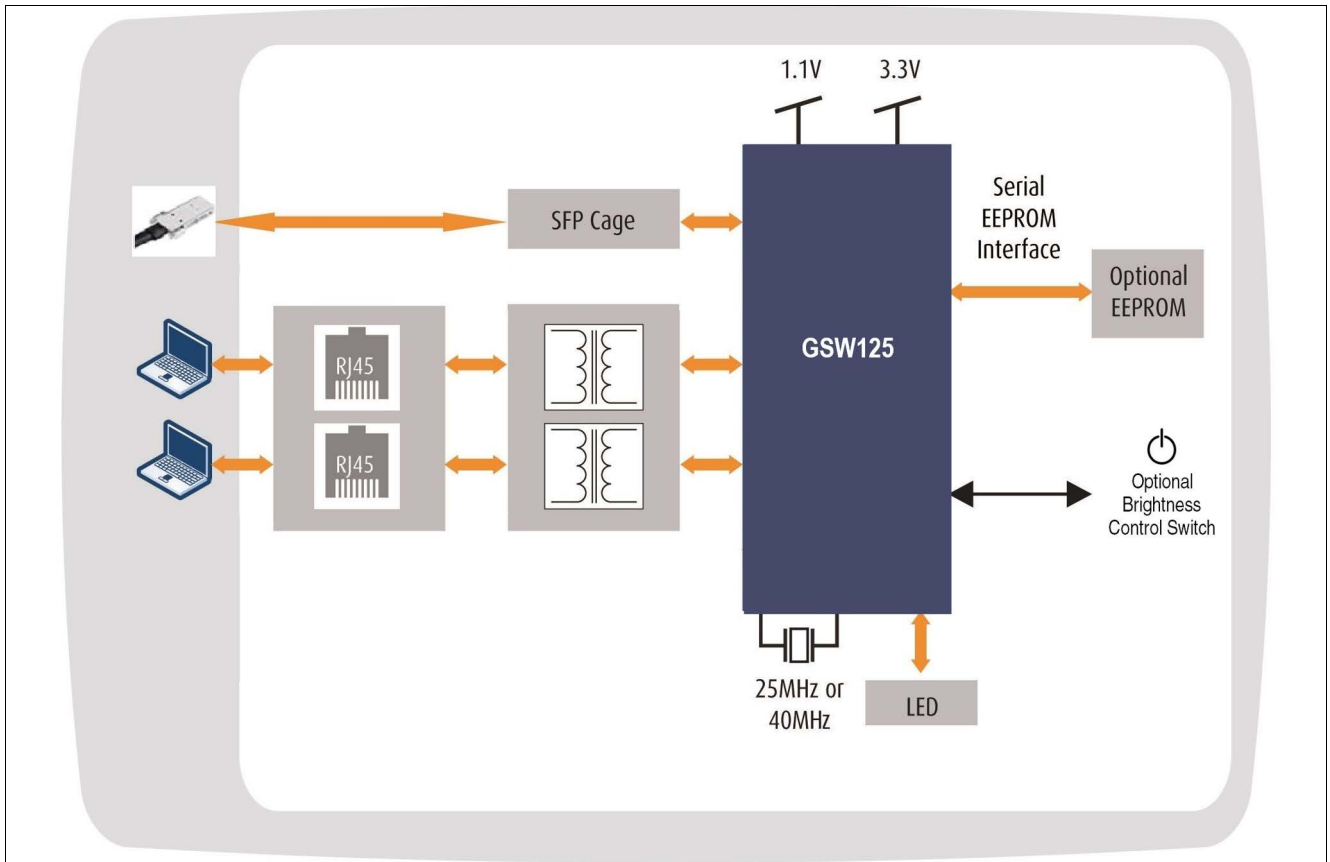

**Figure 2 Standalone Desktop Switch with an Optional Brightness Control Switch**

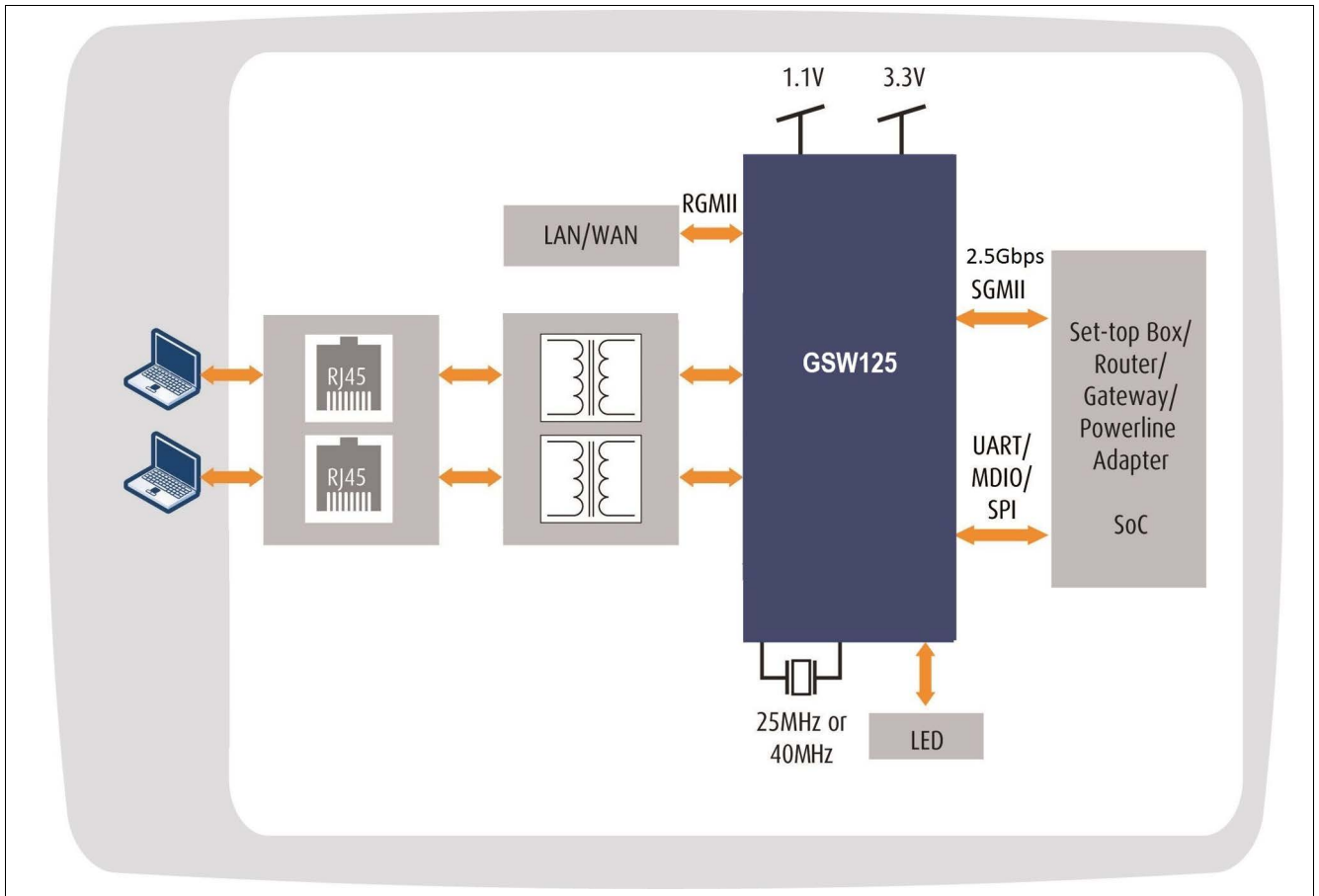

Figure 3 Home Gateway

### 1.3 Block Diagram

Figure 4 shows the block diagram.

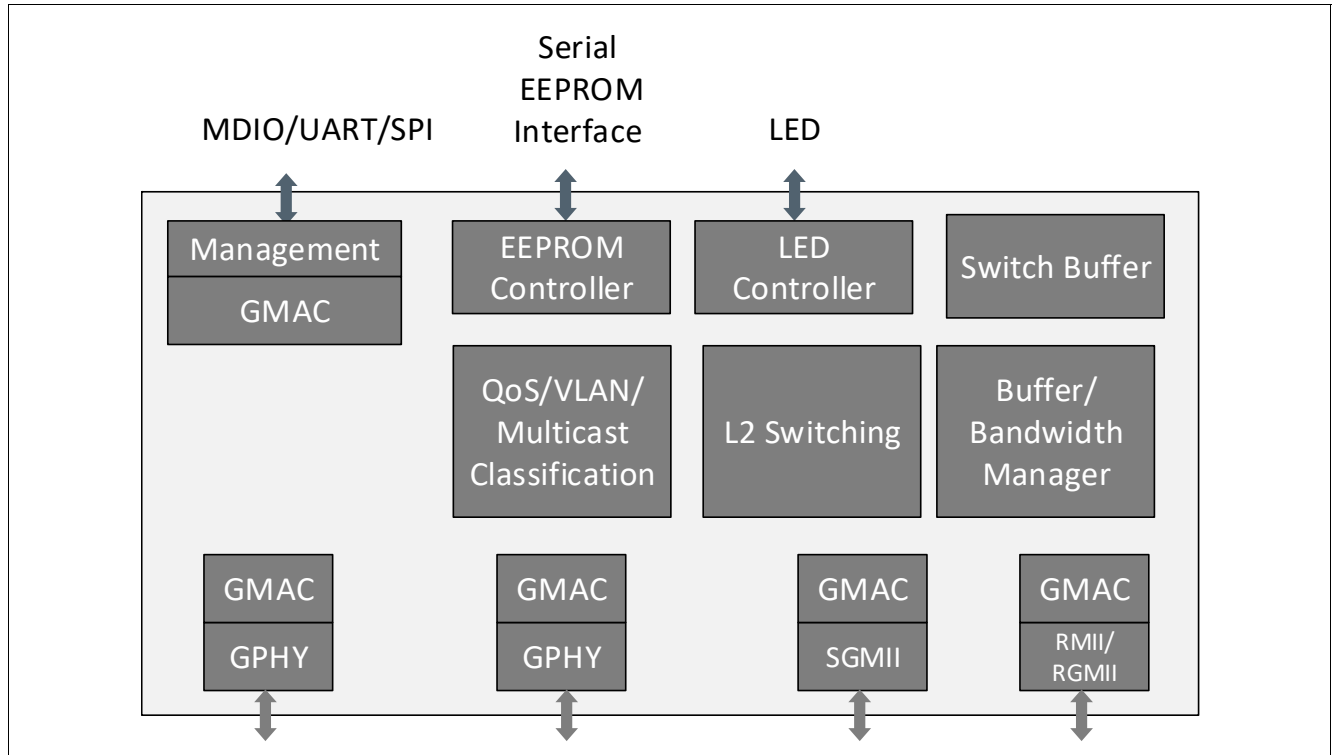

Figure 4 Block Diagram

## 2 External Signals

This chapter describes the signal mapping to the package.

### 2.1 Logic Symbol

Figure 5 gives a global overview of the device's external interfaces.

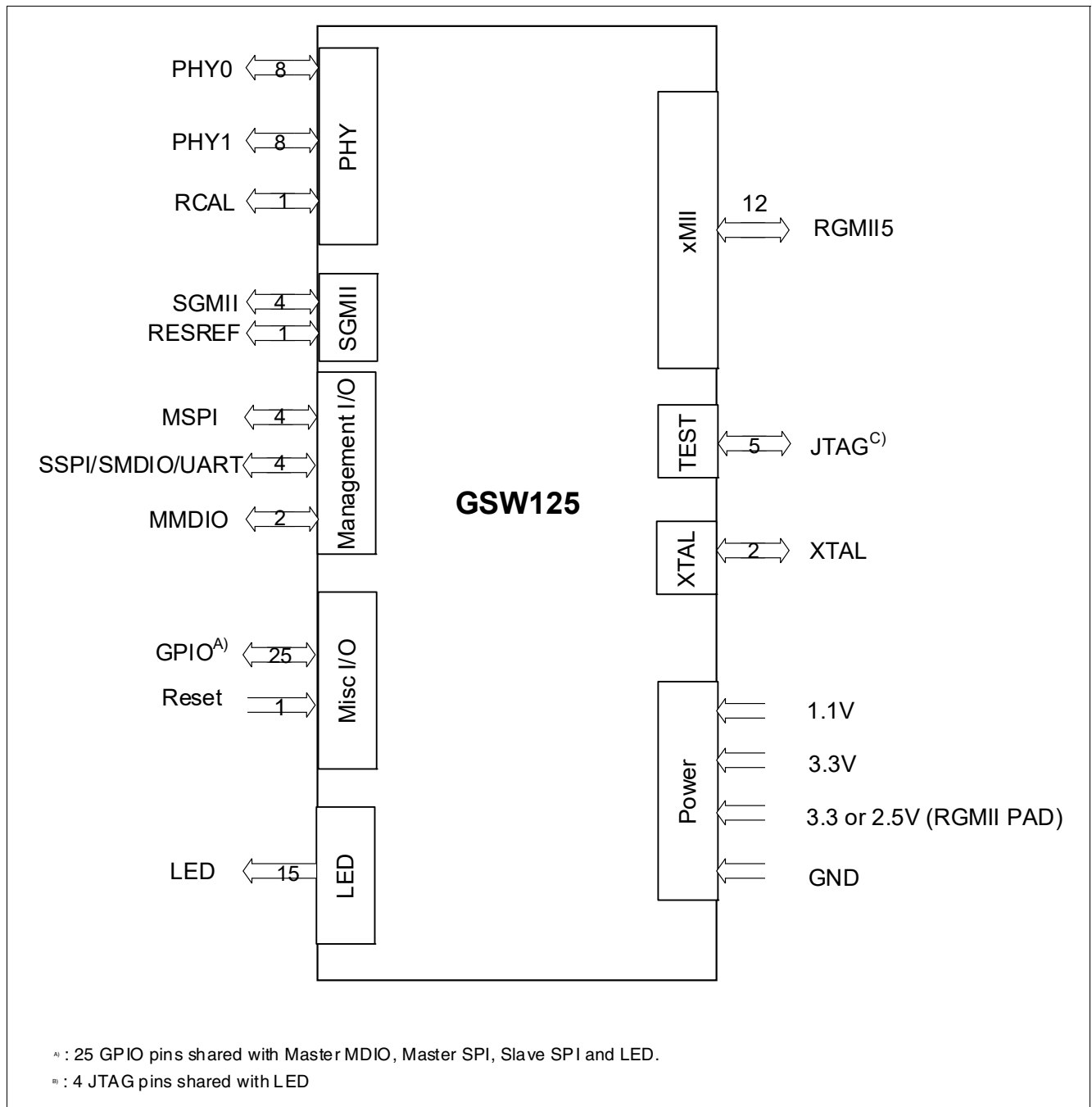

Figure 5 GSW125 Logic Symbol

## 2.2 External Signal Description

This section provides in detail the pin diagrams, abbreviations for pin types and buffer types, as well as the table of input and output signals.

### 2.2.1 Pin Diagram

Figure 6 shows the pin layout of the package.

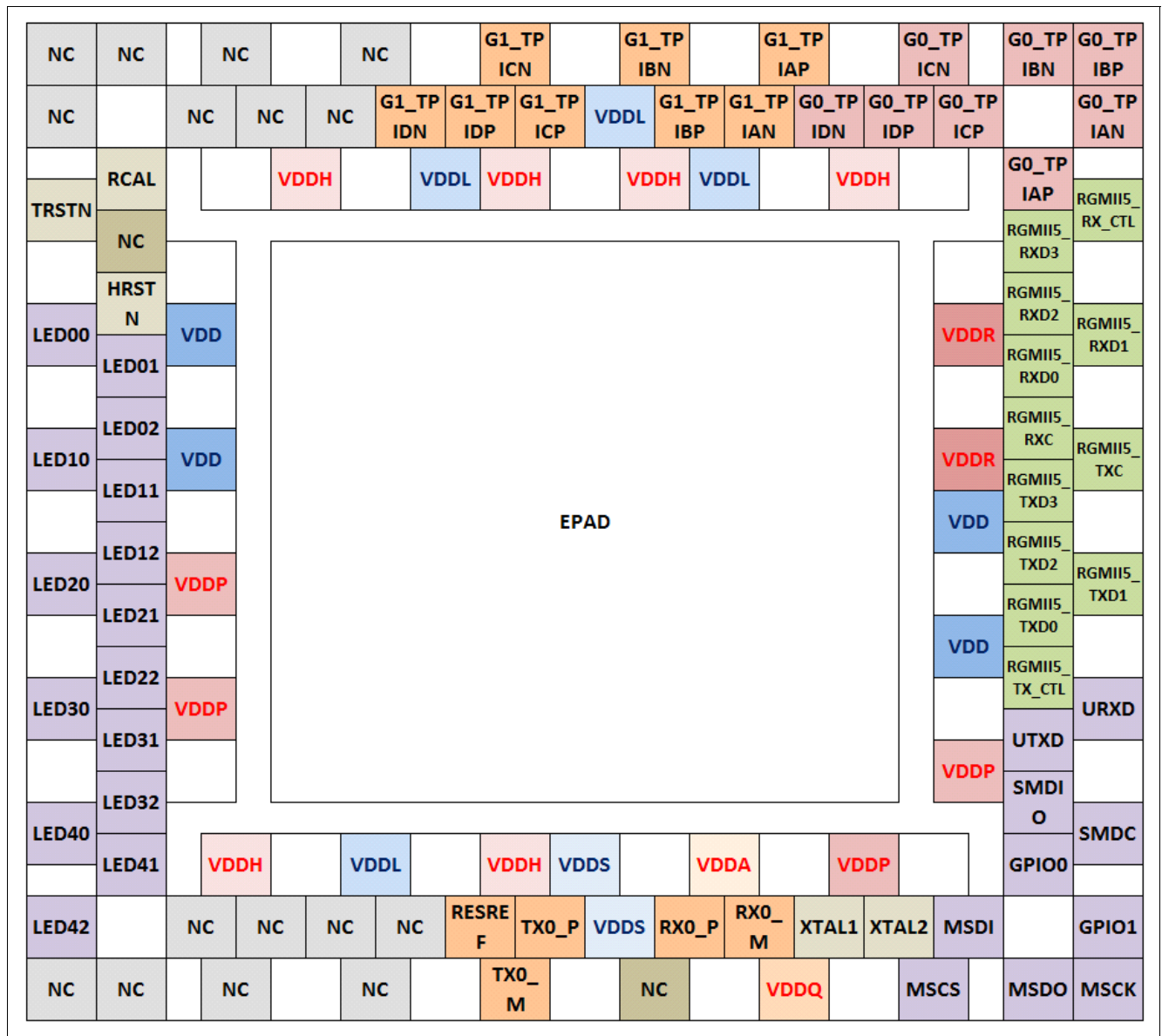

Figure 6 Pin Layout

## 2.2.2 Abbreviations

**Table 1** and **Table 2** summarize abbreviations used in the signal tables.

**Table 1 Abbreviations for Pin Type**

| Abbreviations | Description  |
|---------------|--|
| I             | Input-only, digital levels   |
| O             | Output-only, digital levels  |
| I/O           | Bidirectional input/output signal, digital levels                                    |
| Prg           | Bidirectional pad, programmable to operate either as input or output, digital levels |
| AI            | Input-only, analog levels  |
| AO            | Output-only, analog levels   |
| AI/O          | Bidirectional, analog levels   |
| PWR           | Power  |
| GND           | Ground   |

**Table 2 Abbreviations for Buffer Type**

| Abbreviations    | Description   |
|------------------|---|
| LVTTTL n         | LVTTTL characteristics, n = A, B, or C (driver strength)  |
| LVTTTL n PU m    | LVTTTL characteristics with weak pull-up device;<br>n = A, B, or C (driver strength); m = A, B, or C (pull-up strength)     |
| LVTTTL n PD m    | LVTTTL characteristics with weak pull-down device;<br>n = A, B, or C (driver strength); m = A, B, or C (pull-down strength) |
| LVTTTL n OD      | LVTTTL characteristics with open-drain characteristic, n = A, B, or C (driver strength)                                     |
| LVTTTL n PP      | LVTTTL characteristics with push-pull characteristic, n = A, B, or C (driver strength)                                      |
| I <sup>2</sup> C | I <sup>2</sup> C bus characteristics, open drain, see the AC/DC specification for details.                                  |
| A                | Analog characteristics, see the AC/DC specification for details.  |

## 2.2.3 Input/Output Signals

Table 3 to Table 8 show a detailed description of all pins.

### 2.2.3.1 Ethernet Media Interface

**Table 3 Ethernet Media Interface Signals**

| Pin No.   | Name     | Pin Type | Buffer Type | Function   |
|---|----------|----------|-------------|--|
| <b>Ethernet Port 0 Ethernet Media Interface</b> |          |          |             |  |
| B36   | G0_TPIAP | AI/AO    | A           | <b>Port 0 Transmit/Receive Positive/Negative<br/>Connect directly to XFMR without any pull-down<br/>terminators, such as resistors or capacitors,<br/>required</b> |
| A39   | G0_TPIAN | AI/AO    | A           |  |
| D4  | G0_TPIBP | AI/AO    | A           |  |
| A40   | G0_TPIBN | AI/AO    | A           |  |
| B37   | G0_TPICP | AI/AO    | A           |  |
| A41   | G0_TPICN | AI/AO    | A           |  |
| B38   | G0_TPIDP | AI/AO    | A           |  |
| B39   | G0_TPIDN | AI/AO    | A           |  |
| <b>Ethernet Port 1 Ethernet Media Interface</b> |          |          |             |  |
| A43   | G1_TPIAP | AI/AO    | A           | <b>Port 1 Transmit/Receive Positive/Negative<br/>Connect directly to XFMR without any pull-down<br/>terminators, such as resistors or capacitors,<br/>required</b> |
| B40   | G1_TPIAN | AI/AO    | A           |  |
| B41   | G1_TPIBP | AI/AO    | A           |  |
| A45   | G1_TPIBN | AI/AO    | A           |  |
| B43   | G1_TPICP | AI/AO    | A           |  |
| A47   | G1_TPICN | AI/AO    | A           |  |
| B44   | G1_TPIDP | AI/AO    | A           |  |
| B45   | G1_TPIDN | AI/AO    | A           |  |
| <b>Ethernet Port Calibration</b>                |          |          |             |  |
| B1  | RCAL     | AI/AO    | A           | <b>Calibration for all GPHY Ethernet Ports</b>   |



### 2.2.3.2 SGMII Interface

**Table 4 SGMII Interface Signals**

| Pin No. | Name          | Pin Type | Buffer Type | Function  |
|---------|---------------|----------|-------------|---|
| B20     | <b>RX0_P</b>  | AI       | HD          | <b>Differential SGMII Data Input Pair</b><br>These are the negative and positive signals respectively of the differential input pair of the SGMII SerDes interface. The pair samples a 1.25/3.125 GT/s differential data signal. These pins must be AC-coupled. Due to the integrated CDR, no external transmission peer source-synchronous clock is required. These pins must be AC-coupled. |
| B21     | <b>RX0_M</b>  | AI       | HD          |   |
| B18     | <b>TX0_P</b>  | AO       | HD          | <b>Differential SGMII Data Output Pair</b><br>These are the negative and positive signals respectively of the differential output pair of the SGMII SerDes interface. The pair samples a 1.25/3.125 GT/s differential data signal.  |
| A19     | <b>TX0_M</b>  | AO       | HD          |   |
| B17     | <b>RESREF</b> | AO       | A           | <b>Pad to connect external tuning resistor</b>  |

### 2.2.3.3 Ethernet Media Independent Interface

**Attention:** The pin functionality in [Table 5](#) highlighted in bold indicates the pin name.

**Table 5 Ethernet Media Independent Interface Signals**

| Pin No.  | Name  | Pin Type | Buffer Type | Function  |
|--|---|----------|-------------|---|
| <b>Ethernet Port 5 Media Independent Interface</b> |   |          |             |   |
| A34  | <b>RGMII5_TXC</b><br><b>RMII5_REF_CLK</b>   | O        | PD          | RGMII: Transmit Clock for pins RGMII5_TX*<br>RMII: REF_CLK (50 MHz. Programmable as either Output or Input) |
| B29  | <b>RGMII5_TXD0</b><br><b>RMII5_TXD0</b>     | O        |             | RMII/RGMII Transmit Data Bit 0  |
| A32  | <b>RGMII5_TXD1</b><br><b>RMII5_TXD1</b>     | O        |             | RMII/RGMII Transmit Data Bit 1  |
| B30  | <b>RGMII5_TXD2</b>                          | O        |             | RGMII Transmit Data Bit 2   |
| B31  | <b>RGMII5_TXD3</b>                          | O        |             | RGMII Transmit Data Bit 3   |
| B28  | <b>RGMII5_TX_CTL</b><br><b>RMII5_TX_CTL</b> | O        |             | RMII/RGMII Transmit Control   |
| B32  | <b>RGMII5_RXC</b>                           | I        | PD          | RGMII Receive Clock for pins RGMII5_RX*   |
| B33  | <b>RGMII5_RXD0</b><br><b>RMII5_RXD0</b>     | I        | PD          | RMII/RGMII Receive Data Bit 0   |
| A36  | <b>RGMII5_RXD1</b><br><b>RMII5_RXD1</b>     | I        | PD          | RMII/RGMII Receive Data Bit 1   |
| B34  | <b>RGMII5_RXD2</b>                          | I        | PD          | RGMII Receive Data Bit 2  |

**Table 5 Ethernet Media Independent Interface Signals (cont'd)**

| Pin No. | Name                                       | Pin Type | Buffer Type | Function   |
|---------|--|----------|-------------|--|
| B35     | <b>RGMI5_RXD3</b>                          | I        | PD          | RGMI Receive Data Bit 3  |
| A38     | <b>RGMI5_RX_CTL</b><br><b>RMII5_CRD_DV</b> | I        | PD          | RGMI: Receive Control<br>RMII: Carrier Sense and Data Valid<br>This is the carrier sense/data valid signal and encodes the RX_DV and CRS signals of the RMII, according to the RMII specification. The signal polarity is active high. |

### 2.2.3.4 LED/UART/JTAG Interface

The LED interface is used to connect the external LEDs for Ethernet status indication of the Ethernet PHY interfaces. The single and dual color LEDs are supported. There are three LEDs per port. The JTAG interface shares the pins with the LED interface.

**Attention: The pin functionality in Table 6 highlighted in bold indicates the pin name.**

**Table 6 LED Interface Signals**

| Pin No.            | Name         | Pin Type | Buffer Type | Function  |
|--------------------|--------------|----------|-------------|---|
| <b>LED Signals</b> |              |          |             |   |
| A4                 | GPIO16       | Prg      | Prg         | <b>General Purpose IO 16</b><br>It can be selected as input or output mode.<br>The output characteristic can be selected to be open drain or push-pull. |
|                    | <b>LED00</b> | O        |             | <b>LED0 for Port 0</b><br>LED control output, freely configurable, drives single-color or dual color LEDs.  |
| A6                 | GPIO17       | Prg      | Prg         | <b>General Purpose IO 17</b><br>It can be selected as input or output mode.<br>The output characteristic can be selected to be open drain or push-pull. |
|                    | <b>LED10</b> | O        |             | <b>LED0 for Port 1</b><br>LED control output, freely configurable, drives single-color or dual color LEDs.  |
|                    | TDO          | O        |             | <b>JTAG Serial Test Data Output</b><br>JTAG test data output  |
| A8                 | GPIO18       | Prg      | Prg         | <b>General Purpose IO 18</b><br>It can be selected as input or output mode.<br>The output characteristic can be selected to be open drain or push-pull. |
|                    | <b>LED20</b> | O        |             | <b>Reserved</b>   |
|                    | TDI          | I        | PU          | <b>JTAG Serial Test Data Input</b>  |
| A10                | GPIO19       | Prg      | Prg         | <b>General Purpose IO 19</b><br>It can be selected as input or output mode.<br>The output characteristic can be selected to be open drain or push-pull. |
|                    | <b>LED30</b> | O        |             | <b>Reserved</b>   |
|                    | TMS          | I        | PU          | <b>JTAG Test Mode Select</b>  |

**Table 6 LED Interface Signals (cont'd)**

| Pin No. | Name   | Pin Type | Buffer Type | Function   |
|---------|--------|----------|-------------|--|
| A12     | GPIO20 | Prg      | Prg         | <b>General Purpose IO 20</b><br>It can be selected as input or output mode.<br>The output characteristic can be selected to be open drain or push-pull.  |
|         | TCK    | I        | PU          | <b>JTAG Test Clock</b><br>The signals TDI, TDO and TMS are synchronous subject to this JTAG test clock.<br><i>Note: When JTAG Controller is held in reset state, i.e. Gigabit Ethernet Switch operates in normal mode, this clock pin does not have to be clocked.</i> |
| B4      | GPIO21 | Prg      | Prg         | <b>General Purpose IO 21</b><br>It can be selected as input or output mode.<br>The output characteristic can be selected to be open drain or push-pull.  |
|         | LED01  | O        |             | <b>LED1 for Port 0</b><br>LED control output, freely configurable, drives single-color or dual-color LEDs.   |
| B6      | GPIO22 | Prg      | Prg         | <b>General Purpose IO 22</b><br>It can be selected as input or output mode.<br>The output characteristic can be selected to be open drain or push-pull.  |
|         | LED11  | O        |             | <b>LED1 for Port 1</b><br>LED control output, freely configurable, drives single-color or dual-color LEDs.   |
| B8      | GPIO23 | Prg      | Prg         | <b>General Purpose IO 23</b><br>It can be selected as input or output mode.<br>The output characteristic can be selected to be open drain or push-pull.  |
|         | LED21  | O        |             | <b>Reserved</b>  |
| B10     | GPIO24 | Prg      | Prg         | <b>General Purpose IO 24</b><br>It can be selected as input or output mode.<br>The output characteristic can be selected to be open drain or push-pull.  |
|         | LED31  | O        |             | <b>Reserved</b>  |
| B12     | GPIO25 | Prg      | Prg         | <b>General Purpose IO 25</b><br>It can be selected as input or output mode.<br>The output characteristic can be selected to be open drain or push-pull.  |
| B5      | GPIO26 | Prg      | Prg         | <b>General Purpose IO 26</b><br>It can be selected as input or output mode.<br>The output characteristic can be selected to be open drain or push-pull.<br><i>Note: This pin reads in pin-strapping information during reset.</i>                                      |
|         | LED02  | O        |             | <b>LED2 for Port 0</b><br>LED control output, freely configurable, drives dual-color or single color LED.  |
|         | LIGHT  | I/O      |             | <b>Light Sensor Input</b><br>Light Sensor Input  |

**Table 6 LED Interface Signals (cont'd)**

| Pin No. | Name   | Pin Type | Buffer Type | Function  |
|---------|--------|----------|-------------|---|
| B7      | GPIO27 | Prg      | Prg         | <b>General Purpose IO 27</b><br>It can be selected as input or output mode.<br>The output characteristic can be selected to be open drain or push-pull.<br><i>Note: This pin reads in pin-strapping information during reset.</i> |
|         | LED12  | O        |             | <b>LED2 for Port 1</b><br>LED control output, freely configurable, drives dual-color or single color LED.   |
| B9      | GPIO28 | Prg      | Prg         | <b>General Purpose IO 28</b><br>It can be selected as input or output mode.<br>The output characteristic can be selected to be open drain or push-pull.<br><i>Note: This pin reads in pin-strapping information during reset.</i> |
|         | LED22  | O        |             | <b>Reserved</b>   |
| B11     | GPIO29 | Prg      | Prg         | <b>General Purpose IO 29</b><br>It can be selected as input or output mode.<br>The output characteristic can be selected to be open drain or push-pull.<br><i>Note: This pin reads in pin-strapping information during reset.</i> |
|         | LED32  | O        |             | <b>Reserved</b>   |
| A13     | GPIO30 | Prg      | Prg         | <b>General Purpose IO 30</b><br>It can be selected as input or output mode.<br>The output characteristic can be selected to be open drain or push-pull.<br><i>Note: This pin reads in pin-strapping information during reset.</i> |
|         | LED42  | I/O      |             | <b>Brightness Control</b><br>This pin is used for the brightness control switch input.  |
| A2      | TRSTN  | I        | PD          | <b>JTAG Test Reset</b><br><i>Note: The integrated pull-down resistor holds the TAP controller in its reset state when the pin is left open. This is a difference to the JTAG specification given by IEEE 1149.1.</i>              |

### 2.2.3.5 Management Interfaces

Five types of serial management interfaces are provided: the SPI master, SPI slave, MDIO slave, MDIO master and UART interfaces.

**Attention:** The pin functionality in [Table 7](#) highlighted in bold indicates the pin name.

**Table 7 Management Interface Signals**

| Pin No.   | Name         | Pin Type | Buffer Type | Function   |
|---|--------------|----------|-------------|--|
| <b>MDIO Master Interface</b>                              |              |          |             |  |
| B25   | <b>GPIO0</b> | Prg      | Prg         | <b>General Purpose IO 0</b><br>It can be selected as input or output mode.<br>The output characteristic can be selected to be open drain or push-pull.   |
|   | GPC0         |          |             | <b>General Purpose Clock 0</b><br>General Purpose clock for Synchronous Ethernet or external devices.  |
|   | EXINT0       |          |             | <b>External Interrupt 0</b><br>The output characteristic can be selected to be open drain or push-pull.  |
|   | MMDIO        | I/O      |             | <b>MDIO Master Data Input/Output</b><br>Serial data input and output according to IEEE 802.3, clause 22.   |
| A27   | <b>GPIO1</b> | Prg      | Prg         | <b>General Purpose IO 1</b><br>It can be selected as input or output mode.<br>The output characteristic can be selected to be open drain or push-pull.   |
|   | GPC1         |          |             | <b>General Purpose Clock 1</b><br>General Purpose clock for Synchronous Ethernet or external devices.  |
|   | EXINT1       |          |             | <b>External Interrupt 1</b><br>The output characteristic can be selected to be open drain or push-pull.  |
|   | MMDC         | O        |             | <b>MDIO Master Clock Output</b><br>Serial clock output according to IEEE 802.3, clause 22.   |
| <b>SPI Slave, MDIO Slave Interface and UART Interface</b> |              |          |             |  |
| A30   | <b>GPIO2</b> | Prg      | Prg         | <b>General Purpose IO 2</b><br>It can be selected as input or output mode.<br>The output characteristic can be selected to be open drain or push-pull.   |
|   | SSDI         | I        |             | <b>SPI Slave Data Input</b><br>SPI interface data input  |
|   | <b>URXD</b>  | I        |             | <b>UART Data Input</b><br>UART interface data input  |
| B27   | <b>GPIO3</b> | Prg      | Prg         | <b>General Purpose IO 3</b><br>It can be selected as input or output mode.<br>The output characteristic can be selected to be open drain or push-pull.<br><i>Note: This pin reads in pin-strapping information during reset.</i> |
|   | SSDO         | O        |             | <b>SPI Slave Data Output</b><br>SPI interface data output.   |
|   | <b>UTXD</b>  | O        |             | <b>UART Data Output</b><br>UART interface data output.   |

**Table 7 Management Interface Signals (cont'd)**

| Pin No.                     | Name  | Pin Type | Buffer Type | Function   |
|-----------------------------|-------|----------|-------------|--|
| A28                         | GPIO4 | Prg      | Prg         | <b>General Purpose IO 4</b><br>It can be selected as input or output mode.<br>The output characteristic can be selected to be open drain or push-pull.   |
|                             | SSCK  | I        |             | <b>SPI Slave Clock</b><br>SPI interface clock.   |
|                             | SMDC  | I        |             | <b>MDIO Slave Clock</b><br>The external controller provides the serial clock of up to 25 MHz on this input.  |
|                             | LIGHT | I/O      |             | <b>Light Sensor Input</b><br>Light Sensor Input.   |
| B26                         | GPIO5 | Prg      | Prg         | <b>General Purpose IO 5</b><br>It can be selected as input or output mode.<br>The output characteristic can be selected to be open drain or push-pull.   |
|                             | SSCS  | I        |             | <b>SPI Slave Chip Select</b><br>SPI interface chip select.   |
|                             | SMDIO | I/O      |             | <b>MDIO Slave Data Input/Output</b><br>The external controller uses this signal to address internal registers and to transfer data to and from the internal registers.   |
|                             | PWLED | O        |             | <b>Power LED</b><br>LED for indicating power up.   |
| <b>SPI Master interface</b> |       |          |             |  |
| B24                         | GPIO6 | Prg      | Prg         | <b>General Purpose IO 6</b><br>It can be selected as input or output mode.<br>The output characteristic can be selected to be open drain or push-pull.   |
|                             | MSDI  | I        |             | <b>SPI Master Data Input</b><br>SPI interface data input.  |
|                             | LIGHT | I/O      |             | <b>Light Sensor Input</b><br>Light Sensor Input.   |
| A26                         | GPIO7 | Prg      | Prg         | <b>General Purpose IO 7</b><br>It can be selected as input or output mode.<br>The output characteristic can be selected to be open drain or push-pull.<br><i>Note: This pin reads in pin-strapping information during reset.</i> |
|                             | MSDO  | O        |             | <b>SPI Master Data Output</b><br>SPI interface data output   |
|                             | PWLED | O        |             | <b>Power LED</b><br>LED for indicating power up  |
| D3                          | GPIO8 | Prg      | Prg         | <b>General Purpose IO 8</b><br>It can be selected as input or output mode.<br>The output characteristic can be selected to be open drain or push-pull.<br><i>Note: This pin reads in pin-strapping information during reset.</i> |
|                             | MSCK  | O        |             | <b>SPI Master Clock</b><br>SPI interface clock   |

**Table 7 Management Interface Signals (cont'd)**

| Pin No. | Name        | Pin Type | Buffer Type | Function   |
|---------|-------------|----------|-------------|--|
| A25     | GPI09       | Prg      | Prg         | <b>General Purpose IO 9</b><br>It can be selected as input or output mode.<br>The output characteristic can be selected to be open drain or push-pull.<br><i>Note: This pin reads in pin-strapping information during reset.</i> |
|         | <b>MSCS</b> | O        |             | <b>SPI Master Chip Select</b><br>SPI interface chip select. Active low signal.   |

### 2.2.3.6 Miscellaneous Signals

**Attention:** The pin functionality in [Table 8](#) highlighted in bold indicates the pin name.

**Table 8 Miscellaneous Signals**

| Pin No.   | Name         | Pin Type | Buffer Type | Function  |
|---|--------------|----------|-------------|---|
| <b>Reset and Clocking</b>   |              |          |             |   |
| B22   | <b>XTAL1</b> | AI       | A           | <b>Crystal: Oscillator Input</b><br>A crystal must be connected between XTAL1 and XTAL2. Additional Load Capacitances must tie both pins to the GND.  |
|   | CLK          | I        |             | <b>Clock: Clock Input</b><br>Direct clock input.  |
| B23   | <b>XTAL2</b> | AO       | A           | <b>Crystal: Oscillator Output</b><br>A crystal must be connected between XTAL1 and XTAL2. Additional Load Capacitances must tie both pins to the GND. |
| B3  | <b>HRSTN</b> | I        | PU          | <b>Hardware Reset</b><br>Asynchronous active low device reset   |
| A21, B2   | <b>NC</b>    | -        | -           | <b>Not Connected</b><br>Must be connected to ground   |
| A49, B46, B47, A51, B48, A52, D1, A1, D2, A14, B13, A15, B14, B15, A17, B16 | <b>NC</b>    | -        | -           | <b>Not Connected</b><br>Leave open.   |

### 2.2.3.7 Power Supply

This section specifies the power supply pins.

**Table 9 Power Supply Pins**

| Pin No.                      | Name        | Pin Type | Buffer Type | Function   |
|------------------------------|-------------|----------|-------------|--|
| C10, C14, C31, C34, C36, C39 | <b>VDDH</b> | PWR      |             | <b>High-Voltage Domain Supply</b><br>This is the group of supply pins for the high voltage domain. It supplies the Line-Driver in the PMA of the Gigabit Ethernet Switch. This supply must provide a nominal voltage of $V_{DDH}=3.3\text{ V}$ with a worst case tolerance $\pm 5\%$ at the corners, respectively. |
| C6, C8, C19, C21             | <b>VDDP</b> | PWR      |             | <b>Pad-Voltage Domain P Supply</b><br>This is the group of supply pins for the pad-supply of the Gigabit Ethernet Switch (excluding RGMII). This supply must provide a nominal voltage of $V_{DDP}=3.3\text{ V}$ with a worst case tolerance $\pm 5\%$ at the corners, respectively.                               |
| C26, C28                     | <b>VDDR</b> | PWR      |             | <b>Pad Voltage Domain R Supply</b><br>This is the group of supply pins for the RGMII pad-supply of the Gigabit Ethernet Switch. This supply must provide a nominal voltage of $V_{DDR}=3.3\text{ V}$ or $2.5\text{ V}$ with a worst case tolerance $\pm 5\%$ at the corners, respectively.                         |
| B42, C12, C33, C37           | <b>VDDL</b> | PWR      |             | <b>Low-Voltage Domain Supply</b><br>This is the group of supply pins for the low voltage domain. It supplies mixed signal blocks in the PMA of the Gigabit Ethernet Switch. This supply must provide a nominal voltage of $V_{DDL}=1.1\text{ V}$ with a worst case tolerance $\pm 5\%$ .                           |
| C17                          | <b>VDDA</b> | PWR      |             | <b>XO Pad-Voltage Domain P Supply</b><br>This is the group of supply pins for the pad-supply of the ROPLL and XO. This supply must provide a nominal voltage of $V_{DDSP}=3.3\text{ V}$ with a worst case tolerance $\pm 5\%$ at the corners, respectively.  |
| C15, B19                     | <b>VDDS</b> | PWR      |             | <b>SGMII Low-Voltage Domain Supply</b><br>This is the group of supply pins for the low voltage domain of the SGMII interface. It supplies mixed signal blocks in the PMA of the SGMII interface. This supply must provide a nominal voltage of $V_{DDSL}=1.1\text{ V}$ with a worst case tolerance $\pm 5\%$ .     |
| A23                          | <b>VDDQ</b> | PWR      |             | <b>Fusing Domain Supply</b><br>This pin must be tied to ground.  |
| C2, C4, C23, C25             | <b>VDD</b>  | PWR      |             | <b>Core-Voltage Domain Supply</b><br>This is the group of supply pins for the core voltage domain. It supplies the digital core blocks of the Gigabit Ethernet Switch. This supply must provide a nominal voltage of $V_{DDC}=1.1\text{ V}$ with a worst case tolerance $\pm 5\%$ .                                |
| EPAD <sup>1)</sup>           | <b>VSS</b>  | GND      |             | <b>General Device Ground</b>   |

1) The EPAD is the exposed pad at the bottom of the package. This pad must be properly connected to the ground plane of the PCB.



## 3 Functional Description

This chapter includes the functional description.

### 3.1 Clock and Reset

This section describes the clock and reset.

#### 3.1.1 Clock Generation Unit

A single clock source connects to the system, the internal clock circuit generates all required clocks through the internal PLL circuits. The clock source must be 25 MHz or 40 MHz, selected via pin strapping of pin UTXD.

#### 3.1.2 General Purpose Clock Output

There are two general purpose clocks supported. General purpose clock share the pins with other functions.

The general purpose clock output has frequency of 125/N MHz, where N is configurable via register [SYSCLK\\_CONF](#) field [CLK250\\_DIV](#).

#### 3.1.3 Reset Generation Unit

There are the following reset sources that can bring chip or partial of chip into reset:

- Hardware Reset Input
- Global Software Reset
- Module Software Reset

Hardware input resets all hardware modules and loads pin-strapping information into the register. Hardware input reset is the most thorough reset among the reset choices. Driving HRSTN pin low causes an asynchronous reset of the entire device. HRST pin high deasserts the reset. The configuration input pin(s) are sampled and latched at the rising edge of HRSTN signal. Hardware reset resets all logics in digital and analog domains.

Global software reset (SRST) is issued by the external controller or by boot loader to reset the whole chip. A global software reset does not latch boot strapping information again. The following registers are not affected by global software reset.

- All clock generation configuration registers
- Pin-strapping registers

Individual module software Reset is another type of reset. When the software detects a condition which requires the individual module to be reset, a software reset can be performed by writing to a special register, the Reset Request register. Write '1' to [RST\\_REQ](#) register to assert software reset and write '0' to [RST\\_REQ](#) register to deassert software reset. The duration of reset is controlled by the software. There is an additional self-clearing reset for the first GPHY Macro (GHY0 Macro).

#### 3.1.4 Power Up Sequence

VDDP/VDDH/VDDA must be up before VDDL/VDDS/VDD.

## **3.2 Management Interface Functional Description**

This section includes the Management Interface functional description.

### **3.2.1 Management Interface Subsystem Features**

The Management Interface Subsystem supports the following features:

- Four concurrent types of management interface:
  - MDIO slave interface or SPI slave interface (share pins with GPIO)
  - UART interface or SPI slave interface (share pins with GPIO)
  - SPI master interface (share pins with GPIO)
  - MDIO master interface (share pins with GPIO)
- MDIO master interface to control PHY devices
  - Support auto polling of internal and external PHY devices registers
  - Support indirect access by command to internal and external PHY devices registers
  - Support programmable MDC clock up to 17 MHz
- SPI master interface connecting to a serial EEPROM
  - Support clock up to 42 MHz
  - Supports automatic switch configuration from external EEPROM memory
  - Support write access to EEPROM by an external controller
  - Supports different EEPROM sizes from 1 Kbit to 1024 Kbit
- SPI slave interface to allow control by an external master (such as router or microcontroller)
  - Maximum SPI interface clock 50 MHz and Minimum SPI interface clock is 2.5 MHz
- MDIO slave to allow control by an external master (such as router or microcontroller)
  - Maximum MDIO interface clock 25 MHz
- UART interface connecting to serial terminal
  - Support various baud rate: 4800, 9600, 19200, 38400, 57600, 115200 (default), 230400, 460800, 921600
  - Supports 8-bit data frame, LSB first
  - Support even parity and no parity mode
  - Support 1 or 2 stop bits
  - Support single read access and single write access via serial terminal
  - Support access abort via special characters

### 3.2.2 MDIO Master Module

The Management Data Input/Output (MDIO) master module provides the register interface to access external or internal PHY registers. The access is triggered by an internal bus master access or by an automatic PHY status polling function. See [Figure 8](#) for details.

This interface is used to configure the internal and external PHYs and to read status information (speed, duplex, pause, EEE capability). Access to the MDIO master registers automatically starts a serial access to the internal or external component that is addressed by the PHY address given with the command.

The interface uses the serial protocol defined by IEEE 802.3, clause 22. Up to 32 external devices can be addressed through a 5-bit PHY address (PHYADR). Each of these devices can have up to 32 16-bit registers, selected by a 5-bit register address (REGADR). PHY and register address are given in the command word. Each data transfer covers a 16-bit data word.

#### High Speed Operation

The MDIO master interface configuration is through [MMDC\\_CFG\\_1](#). The standard MDIO protocol uses a clock rate of 3.4 MHz on MDC, which is also the default setting. To speed up the data exchange, the clock generated on MDC can be increased (when the connected PHY supports this). See the [AC Characteristics](#) for details.

#### MDIO Master Interface Address Assignment

The MDIO address for PHY can be configured through [PHY\\_ADDR\\_0/1/2/3/4/5](#).

**Table 10 Default Master MDIO Address Assignment**

|                     | Default Address | Configuration Register     |
|---------------------|-----------------|----------------------------|
| Port 0 Internal PHY | 0               | <a href="#">PHY_ADDR_0</a> |
| Port 1 Internal PHY | 1               | <a href="#">PHY_ADDR_1</a> |
| Port 2 Reserved     | 2               | <a href="#">PHY_ADDR_2</a> |
| Port 3 Reserved     | 3               | <a href="#">PHY_ADDR_3</a> |
| Port 4 External PHY | 4               | <a href="#">PHY_ADDR_4</a> |
| Port 5 External PHY | 5               | <a href="#">PHY_ADDR_5</a> |

#### Automatic Polling State Machine

An automatic polling state machine is implemented to dynamically read the internal and external PHY registers which reflect the status of the link, the link speed, duplex mode, pause capabilities and 802.3az EEE capabilities. When the automatic polling state machine is enabled on a port (through [MMDC\\_CFG\\_0](#)), the PHY status is read out and corresponding MAC module is configured accordingly.

When MDIO Master interface is accessed by the management action (using the dedicated indirect MDIO register access) it has the higher priority over the auto-polling state machine.

When the MDIO auto-polling state machine is disabled, the link speed, link duplex mode, link status, the pause settings and 802.3az EEE settings hold the previous polled values and can also be configured by the explicit management action.

[Figure 7](#) shows the port loop of the auto-polling FSM. The auto-polling FSM goes sequentially over all ports enabled for auto-polling and applies the auto-polling main loop. The gap between each auto polling main loop is programmable via register [MMDC\\_CFG\\_0](#) field [GAP](#). Ports disabled for auto-polling are skipped. The polling sequence is repeated constantly in an infinite loop.

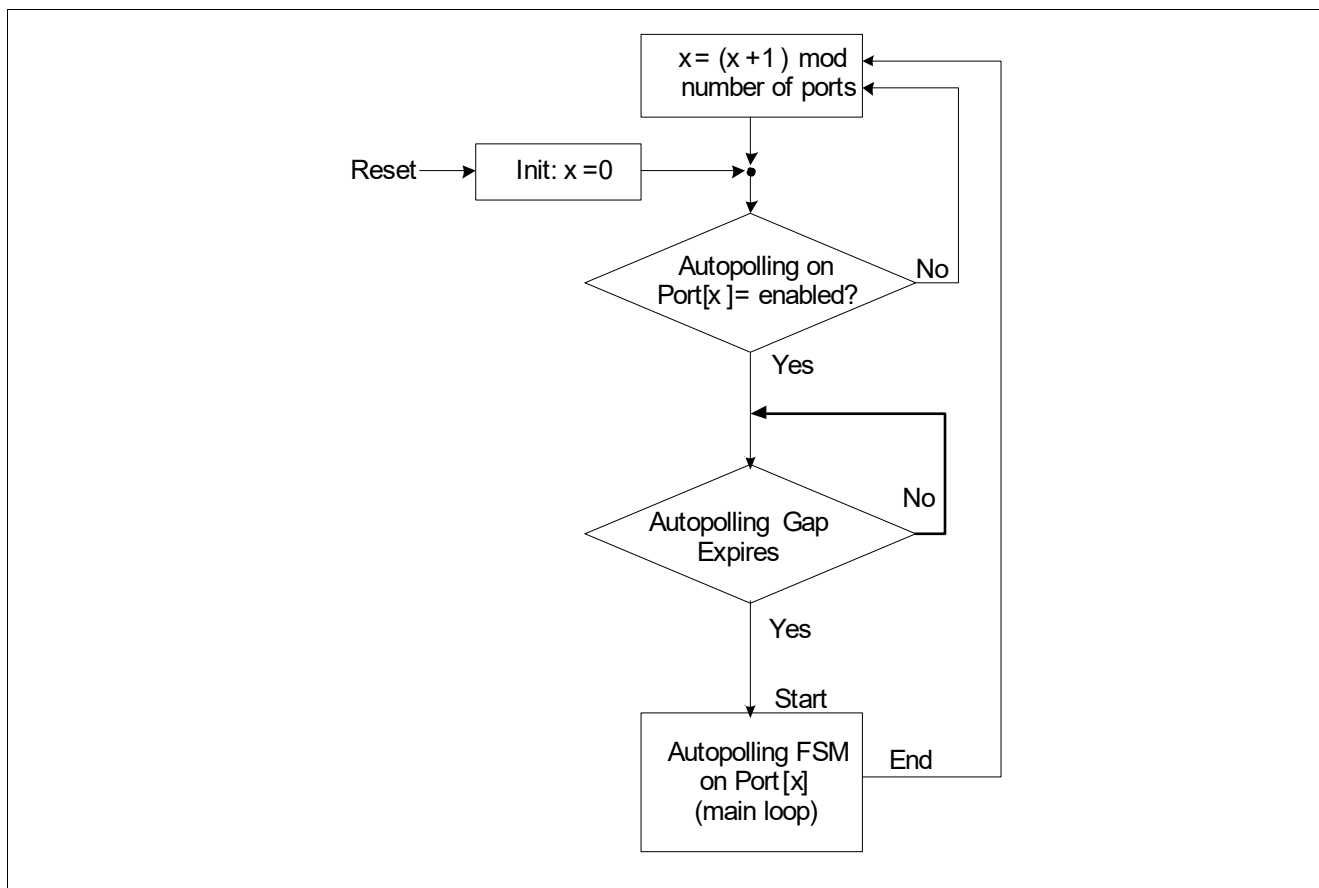

**Figure 7 Auto-polling FSM - Port Loop**

**Figure 8** describes the main loop of the auto-polling state machine. The state machine reads the PHY's registers in the following sequence:

1. Read REG0 and check when the PHY is connected. When the value of the register is all ones, no PHY is assumed to be connected and PHY Inactive status is reported.
2. PHY support of the auto-negotiation (ANEG) is checked in Bit 12 of the REG0. When the PHY does not support ANEG, duplex and speed are based on REG0 settings. Link is based on the bit 2 of REG1. Pause capability is set to the maximum (support symmetric and asymmetric pause).
3. Bit 5 of the REG1 is checked for ANEG status. When ANEG is not complete - current FSM cycle for this port breaks and the Link Status reported as zero. Status of this port is checked again in the next round.
4. When ANEG is complete, the FSM branches based on the bit 8 in REG1. In case there is no extended status supported, the attached PHY is a FE PHY. In case extended status is supported (REG1.8=1<sub>b</sub>) the PHY is GE PHY.
5. For FE PHY, REG5 (partner) and REG4 (local) are fetched for the speed/duplex/pause auto-negotiation result.
6. For GE PHY REG10 (partner) and REG9 (local) are fetched in addition to the FE abilities. REG15 bit 12 to 15 are checked for the 1000BASE-X or 1000BASE-T capability.
7. When bit 1 in REG6 for GE PHY does not indicate reception of the next page, the PHY considered to perform parallel detection and speed/duplex/pause is based on the REG4 and REG5 as in the FE PHY case.
8. EEE capability and advertising registers are fetched.
9. Auto resolution function is applied in the end, based on the fetched result and appropriate status info is reported to the MAC module.

*Note: When automatic polling is enabled, PHY status registers are regularly read. This causes the latching status bits to be reset. When the software must read out the latched status information, the automatic polling must be disabled.*

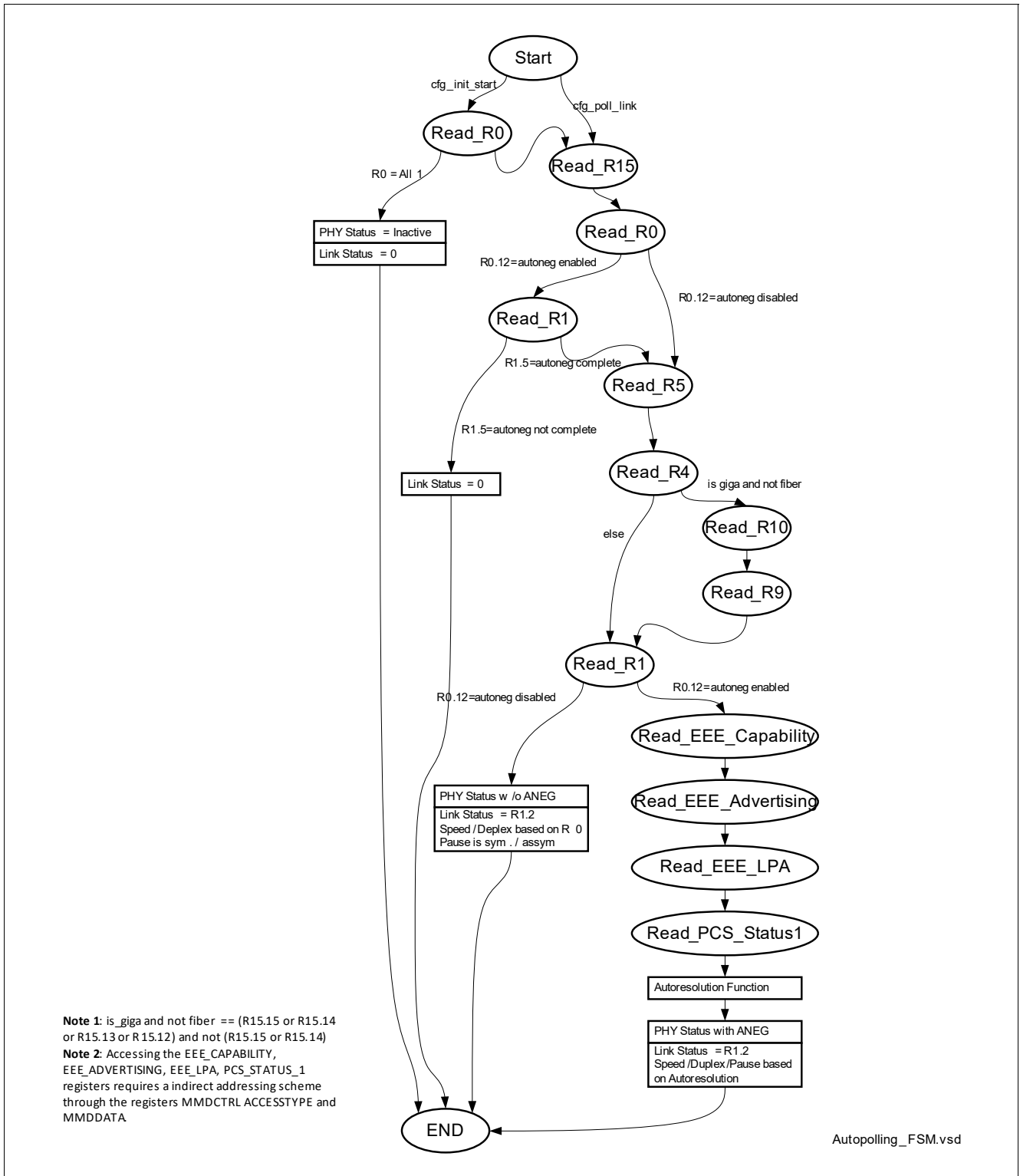

Figure 8 Auto Polling FSM - Main Loop

### MDIO Master Indirect Access

When MDIO Master interface is accessed by the management action (using the dedicated indirect MDIO register access through **MMDIO\_CTRL**, **MMDIO\_READ** and **MMDIO\_WRITE**). It has the higher priority over the auto-polling state machine.

Only single access is supported.

Single Read Access:

Reading data from a PHY register through indirect access is performed in following steps:

The first step can be skipped for the following consecutive access.

1. Read status **MMDIO\_CTRL**.
2. When **MMDIO\_CTRL.MBUSY** is 0<sub>B</sub>, write “operation mode”, “target PHY address” and “target register address” to **MMDIO\_CTRL**.
  - a) **OP** = 10<sub>B</sub> (read)
  - b) **PHYAD** = Target PHY Address
  - c) **REGAD** = Target Register Address
3. Read status **MMDIO\_CTRL**.
4. When **MMDIO\_CTRL.MBUSY** is 0<sub>B</sub>, read data from **MMDIO\_READ**.
  - a) **RDATA** = [result from target register]

Single Write Access:

Writing data to a PHY register through indirect access is performed in following steps:

1. Read status **MMDIO\_CTRL**.
2. When **MMDIO\_CTRL.MBUSY** is 0<sub>B</sub>, write the target data to **MMDIO\_WRITE**.
  - a) **WDATA** = [data to be written]
3. Write “operation mode”, “target PHY address” and “target register address” to **MMDIO\_CTRL**.
  - a) **OP** = 01<sub>B</sub> (write)
  - b) **PHYAD** = Target PHY Address
  - c) **REGAD** = Target Register Address

### 3.2.3 MDIO Slave Module

An external controller can be connected to the switch’s slave MDIO interface. **Figure 9** shows the chip behaves as MDIO slave similar to an PHY. Via indirect addressing the external controller is able to access all internal registers. MDIO Slave module is a master of internal bus. Read and write requests of MDIO slave are translated to read and write requests to internal bus.

For the access to the external or internal PHYs, the chip serves as a proxy for the external controller. The external controller must write the PHY address, the PHY register address, the command (read/write) and the corresponding data into internal registers. Based on the information which has been written, the information is translated into an MDIO frame and sent via the MDIO master interface to the destination PHY.

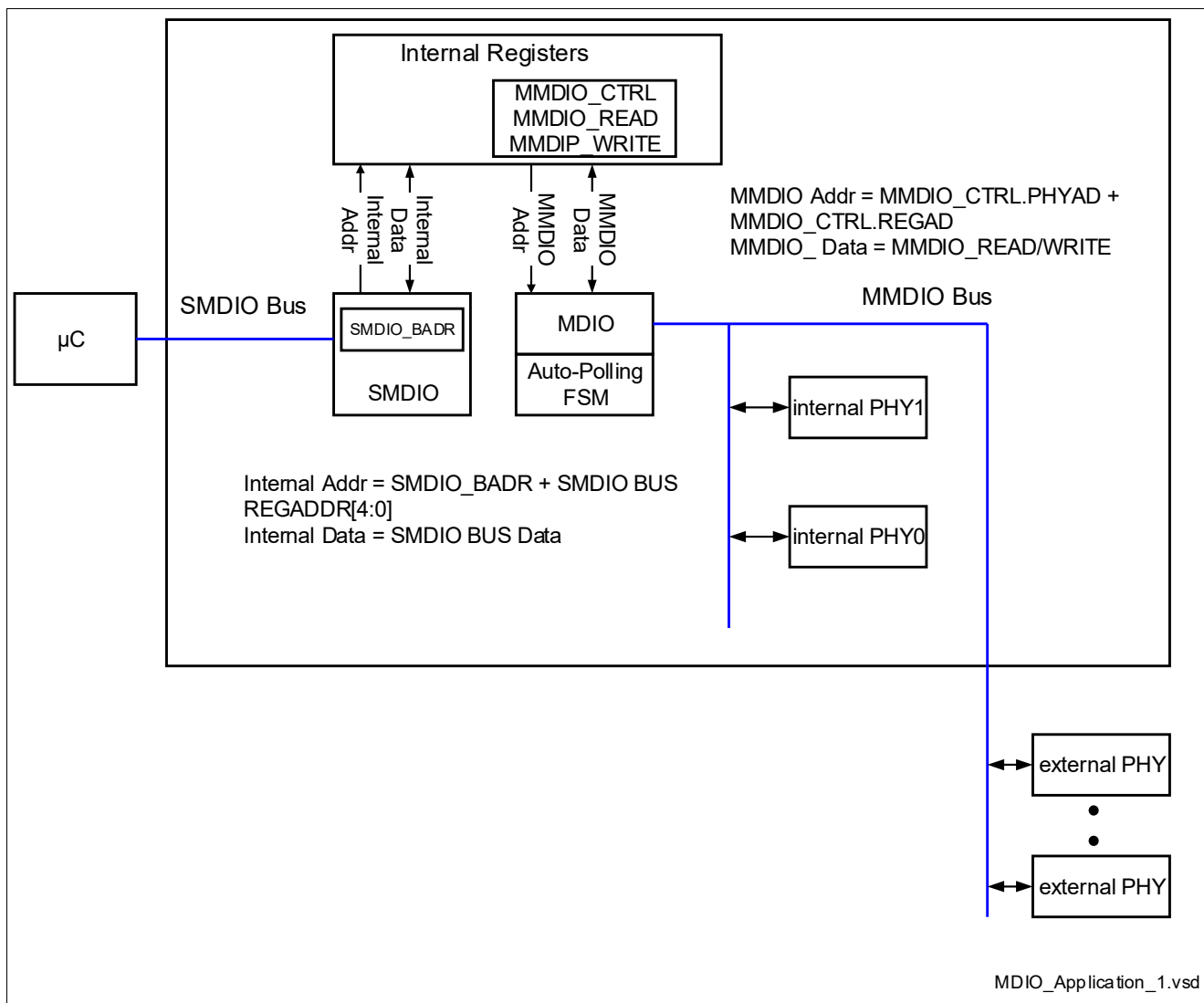

**Figure 9 MDIO Proxy in Switching Mode**

When other devices in the system must be configured through MDIO, they must either be connected to the MDIO master interface or, when connected to the MDIO slave interface, must be configured so that no addressing conflict arises.

The interface can use the standard MDIO protocol which provides vendor-specific registers in the upper 5-bit REGADR range. Within this range there are certain registers which allow an indirect access to multiple internal configuration and status registers.

The standard MDIO protocol requires a 32-bit preamble at the beginning of each read or write access. To speed up the data exchange, the preamble can be reduced down to 1 bit for the second and following subsequent accesses.

The standard MDIO protocol uses a clock rate of 2.5 MHz on MDC. To speed up the data exchange, the clock applied on SMDIO can be increased to maximum 25 MHz. See the [AC Characteristics](#) for details.

The bus protocol used for the MDIO slave interface is the same as defined for MDIO master interface. [Table 10](#) shows the PHY address (PHYADR) range usage. The internal registers are read or written in single or sequential access mode. In sequential access mode, multiple accesses are possible to registers located at subsequent internal addresses.

The SMDIO address used for indirect access is configurable through pin strapping. The SMDIO address are reconfigured via **SMDIO\_CFG.ADDR**.

After hardware reset, MDIO slave interface is enabled. MDIO slave interface is multiplexed with SPI slave interface. MDIO and SPI slave cannot be enabled at the same time. When both are enabled, MDIO slave interface is used. When both interfaces are disabled and all the 4 pins used for MDIO slave and SPI slave are input only.

### Single Read Access

Reading data from an internal register through indirect access is performed in following steps:

The first step can be skipped for consecutive access.

1. Write Base Address Register **SMDIO\_BADR**.
  - a) OPCODE[1:0] = 01<sub>B</sub> (write)
  - b) PHYADR[4:0] = SMDIO Address
  - c) REGADR[4:0] = 11111<sub>B</sub> (Address of Target Base Address Register)
  - d) DATA[15:0] = [Value of Target Base Address]
2. Read Target Data.
  - a) OPCODE[1:0] = 10<sub>B</sub> (read)
  - b) PHYADR[4:0] = SMDIO Address
  - c) REGADR[4:0] = 00000 - 11110<sub>B</sub> (Target Offset Address)
  - d) DATA[15:0] = [Read Data from Target]

### Multiple Read Access

Reading data from an internal register through indirect access can also access the same register multiple times or the consecutive register within a range. This can be used, for example, to read from a FIFO-style memory through a single register address or to poll a register for a certain value. The sequence is as follows:

1. Write Base Address Register **SMDIO\_BADR**.
  - a) OPCODE[1:0] = 01<sub>B</sub> (write)
  - b) PHYADR[4:0] = SMDIO Address
  - c) REGADR[4:0] = 11111<sub>B</sub> (Address of Target Base Address Register)
  - d) DATA[15:0] = [Value of Target Base Address]
2. Read Target Data.
  - a) OPCODE[1:0] = 10<sub>B</sub> (read)
  - b) PHYADR[4:0] = SMDIO Address
  - c) REGADR[4:0] = 00000 - 11110<sub>B</sub> (Target Offset Address)
  - d) DATA[15:0] = [Read Data from Target]
3. Repeat Step 2 when the target register address is within offset 0 to 30 from the target base address.

### Single Write Access

Writing data to an internal register through indirect access is performed in following steps:

1. Write Base Address Register **SMDIO\_BADR**.
  - a) OPCODE[1:0] = 01<sub>B</sub> (write)
  - b) PHYADR[4:0] = SMDIO Address
  - c) REGADR[4:0] = 11111<sub>B</sub> (Address of Target Base Address Register)
  - d) DATA[15:0] = [Value of Target Base Address]
2. Write Target Data.
  - a) OPCODE[1:0] = 01<sub>B</sub> (write)
  - b) PHYADR[4:0] = SMDIO Address
  - c) REGADR[4:0] = 00000 - 11110<sub>B</sub> (Target Offset Address)
  - d) DATA[15:0] = [Write data To Target]



### Multiple Write Access

Writing data to an internal register through indirect access can also access the same register multiple times or the consecutive register within a range. This can be used, for example, to write a FIFO-style memory through a single register address or to write a register for a certain value. The sequence is as follows:

1. Write Base Address Register.
  - a) OPCODE[1:0] = 01<sub>B</sub> (write)
  - b) PHYADR[4:0] = SMDIO Address
  - c) REGADR[4:0] = 11111<sub>B</sub> (Address of Target Base Address Register)
  - d) DATA[15:0] = [Value of Target Base Address]
2. Write Target Data.
  - a) OPCODE[1:0] = 01<sub>B</sub> (read)
  - b) PHYADR[4:0] = SMDIO Address
  - c) REGADR[4:0] = 00000 - 11110<sub>B</sub> (Target Offset Address)
  - d) DATA[15:0] = [Write Data to Target]
3. Repeat Step 2 when the target register address is within offset 0 to 30 from the target base address.

### 3.2.4 SPI Master Module

It supports the following functions:

- Configuration download from an external serial EEPROM after hardware or global software reset is triggered.
- Configuration upload to an external serial EEPROM during run time after initialization is done.

#### Operation

External or internal controller can control SPI master interface via SPI access registers. Operation relies on regular interrupt asserted at the boundary of 8-bit transactions. SPI interrupt indicates that data out buffer is ready to be written and data in carries the valid data and is ready for reading.

An access to an EEPROM/flash requires writing a command byte (refer to the data sheet of the mounted flash memory) to specify the target actions (e.g. erase the device, set the write enable, trigger a page program or a read transaction) and optional address bytes. With every access, data is written (from registers [MSPI\\_DOUT01/MSPI\\_DOUT23/MSPI\\_DOUT45/MSPI\\_DOUT67](#)) as well as read (result stored in [MSPI\\_DIN01/MSPI\\_DIN23/MSPI\\_DIN45/MSPI\\_DIN67](#)).

Operation Configuration:

- First set [MSPI\\_OP.MDSEL](#) to 1<sub>B</sub>.
- Wait until [MSPI\\_OP.MDSTA](#) = 1<sub>B</sub>.
- Do single or multiple manual access operations.

Access Operation:

- Write a flash command and optional address or data to be written into [MSPI\\_DOUT01/MSPI\\_DOUT23/MSPI\\_DOUT45/MSPI\\_DOUT67](#).
- Configure [MSPI\\_MANCTRL.SIZE](#) = number of bytes and [MSPI\\_MANCTRL.START](#) to 1<sub>B</sub>.
- Wait for SPI interrupt [MSPI\\_ISR.DONE](#) = 1<sub>B</sub>.
- Write 1<sub>B</sub> to [MSPI\\_ISR.DONE](#) to clear interrupt.
- In case a read operation must take place, read the result from [MSPI\\_DIN01/MSPI\\_DIN23/MSPI\\_DIN45/MSPI\\_DIN67](#).

### 3.2.5 SPI Slave Access

The Gigabit Ethernet Switch may work as an SPI slave. An external controller manages the Gigabit Ethernet Switch via SPI slave interface.

The SPI Slave module is a master of internal bus. Read and write requests of SPI are translated to read and write requests to internal bus.

The SPI Slave follows the 16-bit/24-bit serial EEPROM-like protocols (for WRITE/READ respectively). **Figure 10** shows the timing diagrams.

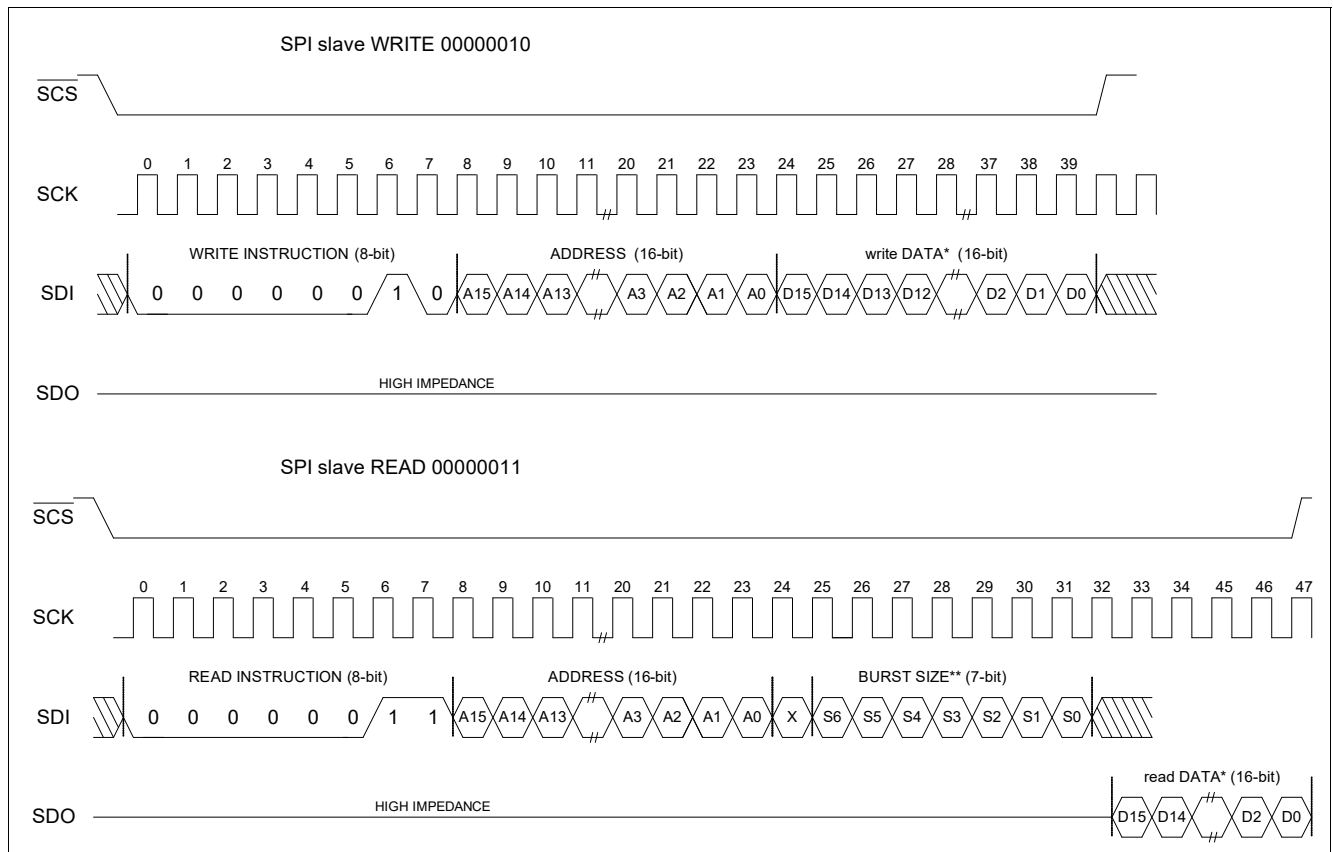

**Figure 10 SPI Slave Access**

An SCK frequency of up to 12.5 MHz is supported.

- In SDI direction, 00000010 is used for the WRITE command and 00000011 is used for the READ command.
- In SDO direction, delay is adjustable in steps of 4 ns from rising or falling edge of SCK.
  - delay is  $(3 + \text{SSPI\_CFG.DRVDLY}) * 4$  ns when  $\text{SSPI\_CFG.DRVDLY} \neq 0$
  - delay is  $4 * 4$  ns when  $\text{SSPI\_CFG.DRVDLY} = 0$
- SDO can also be driven up to 2 SCK cycles earlier than the sequence defined in **Figure 10**.
  - When  $\text{SSPI\_CFG.REFCYC} = 0$ , SDO is driven 2 SCK cycles earlier than the sequence defined in **Figure 10**.
  - When  $\text{SSPI\_CFG.REFCYC} = 1$ , SDO is driven 1 SCK cycle earlier than the sequence defined in **Figure 10**.
  - When  $\text{SSPI\_CFG.REFCYC} = 2$ , SDO is driven as the sequence defined in **Figure 10**.
  - When  $\text{SSPI\_CFG.REFCYC} = 3$ , SDO is driven 1 SCK cycle later than the sequence defined in **Figure 10**.
- When  $\text{SSPI\_CFG.SDIEGSEL}$  is set to 0, SDI is latched with the rising edge of SCK (for example when the master is driving SDI with the falling edge of SCK).
- When  $\text{SSPI\_CFG.SDIEGSEL}$  is set to 1, SDI is latched with the falling edge of SCK (for example when the master is driving SDI with the rising edge of SCK).

### 3.2.6 UART Access

UART supports connection to internal bus of chip via a standard com terminal emulator running on UNIX or Windows. UART module is a master of internal bus. Read and write requests of UART are translated to read and write requests to internal bus. Three commands supported are:

```
> r address16
> w address16 write_data16
> m address16 write_data16 enable_data16
```

The UART module echoes the commands as is, ignoring any character that does not match the command format. The return value of r address16 command includes read\_data16 on a new line.

The format of address16, write\_data16 and enable\_data16 are four consecutive hexadecimal digits between 0000<sub>H</sub> and FFFF<sub>H</sub> or FFFF<sub>H</sub>. The returned read\_data16 is same format in lower case.

After chip reset, UART is in line monitoring state, searching line for valid byte. This must be preceded by at least 12 consecutive ones, (IDLE). When first error-free byte is detected, UART module responds by sending a system message:

System ready! Use:r/w <addr> <data>

followed by prompt sequence:

'\r\n' and '>'

where the 'r' ASCII(13) can be disabled by setting **UART\_CFG.CRDIS**=1 and the '\n' ASCII(10) can be disabled by setting **UART\_CFG.LFDIS**=1 to adjust new line sequence to different platforms (UNIX, MAC, Windows)

The default prompt character '>' can be changed by **UART\_PROMPT.Prompt0** and **UART\_PROMPT.Prompt1**. Up to two prompt characters are supported. Setting the character to zero disables this character.

In addition to 3 commands, the character '#' can be used as a first character of the line and the rest of the line is ignored. The character '#' and following characters are not echoed. In line comment, following the valid command, is ignored as invalid character sequence and no other special handling is required.

When using UART from terminal, the basic editing facilities are provided using '\b' 'backspace' character, ASCII(8). 'b' erases a single character on the current line that is echoed. Ignored characters cannot be erased. Multiple 'b' characters can erase the line up to the prompt. Prompt is not erased.

Any command can be aborted by DEL ASCII(127) or ESC(27) characters. The indication of abort of a command is done by '\$' character. Abort of empty line is not indicated by '\$' character.

The following baud rates are supported: 4800, 9600, 19200, 38400, 57600, 115200 (default), 230400, 460800, 921600. The baud rate is programmed via **UART\_BD** and **UART\_FDIV**. **UART\_BD** is the whole part of divider and **UART\_FDIV** is the fractional part of the divider.

Only 8-bit data format is supported. Parity can be enabled or disabled (default) via **UART\_CFG.PAREN**. Even parity is supported. In receive direction any number of stop bits is supported. In transmit direction, the number of stop bits is configured via **UART\_CFG.STOP**.

### 3.2.7 Boot Loader Description

The device supports the following boot modes:

- Wait for external master (via SPI Slave, MDIO slave or UART) configuration and trigger
- Self-start mode (External EEPROM not attached)
- SPI master EEPROM mode (External EEPROM attached)

The boot mode is determined by pin strapping. See [Pin Strapping](#) for details.

#### Wait For External Master Procedure (PS\_NOWAIT = 0<sub>B</sub>)

When pin strapping indicates that boot mode is “wait for external master”, boot loader only configures slave interface according to pin strapping. External master must configure and enable Gigabit Ethernet Switch core operation.

#### Self-start Mode Procedure (PS\_NOWAIT = 1<sub>B</sub>)

When pin strapping indicates that boot mode is not “wait for external master” and no EEPROM is attached, boot loader configures the registers according to the pin-strapping values shown in [Table 11](#) and [Table 12](#).

[Table 11](#) shows the registers configuration for self-start mode: standalone unmanaged switch sub-mode when PS\_OP\_MD = 01<sub>B</sub>.

**Table 11 Registers Configuration for Self-start Mode: Standalone Unmanaged Switch Sub-Mode**

| Register                         | Field      | Description   | Note  |
|----------------------------------|------------|---|---|
| <a href="#">GPHY0_GPS</a>        | Bit 1 to 0 | = PS_SUBTYPE_MD[4:3]  | LED Display Mode  |
| <a href="#">GPHY1_GPS</a>        | Bit 1 to 0 | = PS_SUBTYPE_MD[4:3]  | LED Display Mode  |
| <a href="#">GPHY2_GPS</a>        | Bit 1 to 0 | = PS_SUBTYPE_MD[4:3]  | Reserved  |
| <a href="#">GPHY3_GPS</a>        | Bit 1 to 0 | = PS_SUBTYPE_MD[4:3]  | Reserved  |
| <a href="#">GPIO_ALTSEL0</a>     | Bit 5 to 4 | =11 <sub>B</sub>  | Enable PWLED alternate function on GPIO7<br>Enable Light alternate function on GPIO6                    |
| <a href="#">GPIO_ALTSEL1</a>     | Bit 5 to 4 | =11 <sub>B</sub>  | Enable PWLED alternate function on GPIO7<br>Enable Light alternate function on GPIO6                    |
| <a href="#">GPIO_PUDEN</a>       | Bit 5 to 4 | =00 <sub>B</sub>  | Disable PWLED and LIGHT pin pull up and pull down   |
| <a href="#">GPIO_OUT</a>         | Bit 5      | = 1 <sub>B</sub>  | Turn on Power LED   |
| <a href="#">GPIO_DRIVE0_CFG</a>  | Bit 5      | = 1 <sub>B</sub>  | Change PWLED drive strength to 12 mA  |
| <a href="#">GPIO2_ALTSEL0</a>    | All field  | Depends on LED mode of pin strapping  | Configured according to <a href="#">Table 13</a>  |
| <a href="#">GPIO2_PUDEN</a>      | All field  | Depends in LED mode of pin strapping  | Configured according to <a href="#">Table 13</a>  |
| <a href="#">GPIO2_DRIVE1_CFG</a> | All field  | Depends in LED mode of pin strapping  | Configured according to <a href="#">Table 13</a>  |
| <a href="#">MII_CFG_5</a>        | Bit 14:13  | When PS_SUBTYPE_MD[0] is 1 <sub>B</sub> :<br>=10 <sub>B</sub>   | Enable RGMII5 interface according to pin strap  |
| <a href="#">PHY_ADDR_5</a>       | All fields | When PS_SUBTYPE_MD[2] is 1 <sub>B</sub> and PS_SUBTYPE_MD[0] is 1 <sub>B</sub> :<br>= 32A5 <sub>H</sub> | For RGMII5 interface, force link on, speed is 1 Gbps, full duplex, pause enable according to pin strap. |

**Table 11 Registers Configuration for Self-start Mode: Standalone Unmanaged Switch Sub-Mode**

| Register                             | Field      | Description        | Note  |
|--------------------------------------|------------|--------------------|---|
| GSWIP<br>PCE_PCTRL_2 for<br>Port 3   | All Field  | =0001 <sub>H</sub> | Enable higher priority for port 3   |
| GSWIP<br>PCE_PCTRL_2 for<br>Port 4   | All Field  | =0001 <sub>H</sub> | Enable higher priority for port 4   |
| BM_WRED_GTH_0                        | All Fields | =0100 <sub>H</sub> | Global watermark is 256 segments.<br>Remaining 256 segments are for<br>buffer reservation |
| BM_WRED_GTH_1                        | All Fields | =0100 <sub>H</sub> | Global watermark is 256 segments.<br>Remaining 256 segments are for<br>buffer reservation |
| PCE_PMAP_2                           | All Fields | =006F <sub>H</sub> | Only port 4 is disabled   |
| PCE_PMAP_3                           | All Fields | =006F <sub>H</sub> | Only port 4 is disabled   |
| MAC_CTRL_4 (for<br>each port)        | All Fields | =1494 <sub>H</sub> | Enable EEE LPI Mode for each port   |
| SDMA_PFCTHR8 (for<br>each port)      | All Fields | =0018 <sub>H</sub> | Configure backpressure watermark<br>for each port   |
| SDMA_PFCTHR9 (for<br>each port)      | All Fields | =001E <sub>H</sub> | Configure backpressure watermark<br>for each port   |
| SDMA_FCTHR1                          | All Fields | =03FF <sub>H</sub> | Configure tail drop watermark   |
| SDMA_FCTHR2                          | All Fields | =03FF <sub>H</sub> | Configure tail drop watermark   |
| SDMA_FCTHR3                          | All Fields | =03FF <sub>H</sub> | Configure tail drop watermark   |
| SDMA_FCTHR4                          | All Fields | =03FF <sub>H</sub> | Configure tail drop watermark   |
| Buffer Reservation for<br>each queue | All Fields | =001E <sub>H</sub> | Buffer Reservation for each queue<br>is 30 segments                                       |
| WRED green min/max<br>for each queue | All Fields | =03FF <sub>H</sub> | Configure WRED green min/max for<br>each queue  |
| Queue weight for each<br>queue       | All Fields | =FFFF <sub>H</sub> | Enable strict priority  |
| <b>GSWIP_CFG</b>                     | All Fields | =8000 <sub>H</sub> | Enable GSWIP and all ports  |

**Table 12** shows the registers configuration for self-start mode: managed switch sub-mode when PS\_OP\_MD = 1x<sub>B</sub>.

**Table 12 Registers Configuration for Self-start Mode: Managed Switch Sub-Mode**

| Register                                       | Field      | Description  | Note  |
|--|------------|--|---|
| Following Configurations when PS_OP_MD is "11" |            |  |   |
| <b>SMDIO_CFG</b>                               | Bit 8 to 4 | When PS_SUBTYPE_MD[1:0] is 0:<br>= 0 <sub>H</sub><br>When PS_SUBTYPE_MD[1:0] is 1:<br>= 4 <sub>H</sub><br>When PS_SUBTYPE_MD[1:0] is 2:<br>= 10 <sub>H</sub><br>When PS_SUBTYPE_MD[1:0] is 3:<br>= 1F <sub>H</sub> | Configure SMDIO Address   |
| Following Configurations when PS_OP_MD is "10" |            |  |   |
| <b>SSPI_CFG</b>                                | Bit 15     | =~PS_SUB_MD[0]   | SDO Driving Edge Selection  |
| <b>SSPI_CFG</b>                                | Bit 14     | =~PS_SUB_MD[1]   | SDI Sampling Edge Selection   |
| <b>SSPI_CFG</b>                                | Bit 0      | =1 <sub>B</sub>  | Enable SSPI   |
| <b>GPIO_ALTSEL0</b>                            | Bit 5 to 2 | =1111 <sub>B</sub>   | Change GPIO to alternate function SSPI  |
| <b>GPIO_ALTSEL1</b>                            | Bit 5 to 2 | =0000 <sub>B</sub>   | Change GPIO to alternate function SSPI  |
| Configurations when PS_OP_MD is "1X"           |            |  |   |
| <b>MII_CFG_5</b>                               | Bit 14:13  | =10 <sub>B</sub>   | Enable RGMII5 interface   |
| <b>PHY_ADDR_5</b>                              | All fields | = 32A5 <sub>H</sub>  | For RGMII5 interface, force link on, speed is 1 Gbps, full duplex, pause enable |
| <b>PCDU_5</b>                                  | Bit 9:7    | When PS_SUBTYPE_MD[4] is 1 <sub>B</sub> :<br>= 4   | Setting RGMII RX delay to 2ns   |
| <b>PCDU_5</b>                                  | Bit 2:0    | When PS_SUBTYPE_MD[3] is 1 <sub>B</sub> :<br>= 4   | Setting RGMII TX delay to 2ns   |
| <b>PHY_ADDR_4</b>                              | All fields | = 32A4 <sub>H</sub>  | Force Port 4 link speed to 1 Gbps or above, pause enable, link on, full duplex  |
| <b>NCO_CTRL</b>                                | Bit 3:1    | When PS_SUBTYPE_MD[2] is 1 <sub>B</sub><br>=111 <sub>B</sub>   | Set SGMII to 2.5 Gbps Mode according to pin strapping                           |
| <b>RST_REQ</b>                                 | All field  | = 0F <sub>H</sub>  | Remove reset for SGMII.   |
| <b>SGMII_PHY_HWBU_CTRL</b>                     | All Fields | =0009 <sub>H</sub>   | Activate hardware bring up FSM  |
| <b>SGMII_PHY_STATUS</b>                        | All Fields | Read wait until bit [11:7]<br>=7   | Check whether HWFSM was brought up correctly                                    |
| <b>SGMII_TBI_TBICTL</b>                        | All Fields | =0033 <sub>H</sub>   | Initialize TBI module keep TBI module enabled                                   |
| <b>SGMII_TBI_TBICTL</b>                        | All Fields | =0032 <sub>H</sub>   | Put TBI module out of init state and keep TBI module enabled                    |
| <b>SGMII_PCS_TXB_CTL</b>                       | All Fields | =0003 <sub>H</sub>   | Initialize TX BUFFER  |

**Functional Description**
**Table 12 Registers Configuration for Self-start Mode: Managed Switch Sub-Mode (cont'd)**

| Register                          | Field      | Description        | Note   |
|-----------------------------------|------------|--------------------|--|
| <a href="#">SGMII_PCS_TXB_CTL</a> | All Fields | =0001 <sub>H</sub> | TX BUFFER running  |
| <a href="#">SGMII_PCS_RXB_CTL</a> | All Fields | =0003 <sub>H</sub> | Initialize RX BUFFER   |
| <a href="#">SGMII_PCS_RXB_CTL</a> | All Fields | =0001 <sub>H</sub> | RX BUFFER running  |
| <a href="#">SGMII_TBI_ANEGCTL</a> | All Fields | =00F0 <sub>H</sub> | RX BUFFER running  |
| <a href="#">SGMII_TBI_LPSTAT</a>  | All Fields | =0021 <sub>H</sub> | Force to full duplex and 1 or 2.5 Gbps speed   |
| BM_WRED_GTH_0                     | All Fields | =0100 <sub>H</sub> | Global watermark is 256 segments.<br>Remaining 256 segments are for buffer reservation |
| BM_WRED_GTH_1                     | All Fields | =0100 <sub>H</sub> | Global watermark is 256 segments.<br>Remaining 256 segments are for buffer reservation |
| MAC_CTRL_4 (for each port)        | All Fields | =1494 <sub>H</sub> | Enable EEE LPI Mode for each port  |
| SDMA_PFCTHR8 (for each port)      | All Fields | =0018 <sub>H</sub> | Configure backpressure watermark for each port   |
| SDMA_PFCTHR9 (for each port)      | All Fields | =001E <sub>H</sub> | Configure backpressure watermark for each port   |
| SDMA_FCTHR1                       | All Fields | =03FF <sub>H</sub> | Configure tail drop watermark  |
| SDMA_FCTHR2                       | All Fields | =03FF <sub>H</sub> | Configure tail drop watermark  |
| SDMA_FCTHR3                       | All Fields | =03FF <sub>H</sub> | Configure tail drop watermark  |
| SDMA_FCTHR4                       | All Fields | =03FF <sub>H</sub> | Configure tail drop watermark  |
| Buffer Reservation for each queue | All Fields | =001E <sub>H</sub> | Buffer Reservation for each queue is 30 segments                                       |
| WRED green min/max for each queue | All Fields | =03FF <sub>H</sub> | Configure WRED green min/max for each queue  |
| Queue weight for each queue       | All Fields | =FFFF <sub>H</sub> | Enable strict priority   |
| <a href="#">GSWIP_CFG</a>         | All Fields | =8000 <sub>H</sub> | Enable GSWIP and all ports   |

**Table 13 LED Status VS LED Mode**

| LED Mode | LEDx0   | LEDx1   | LEDx2   | Configuration   |
|----------|---|---|---|---|
| 0        | 10 Mbps link activity<br>Blinking frequency: 4 Hz<br>Single color or dual color             | 100 Mbps Link Activity<br>Blinking frequency: 4 Hz<br>Single color or dual color  | 1000 Mbps link activity<br>Blinking frequency: 4 Hz<br>Single color or dual color | <b>GPIO2_ALTSEL0</b> = 7FFF <sub>H</sub><br><b>GPIO2_PUDEN</b> = 4000 <sub>H</sub><br><b>GPIO2_DRIVE1_CFG</b> = 7FFF <sub>H</sub> |
| 1        | Link<br>Single color or dual color  | Activity<br>Blinking depends on packet rate<br>Single color or dual color         | GPIO  | <b>GPIO2_ALTSEL0</b> = 43FF <sub>H</sub><br><b>GPIO2_PUDEN</b> = 7C00 <sub>H</sub><br><b>GPIO2_DRIVE1_CFG</b> = 03FF <sub>H</sub> |
| 2        | Link activity<br>Blinking frequency: 4 Hz<br>Single color or dual color                     | 100 Mbps<br>Single color or dual color  | 1000 Mbps<br>Single color or dual color   | <b>GPIO2_ALTSEL0</b> = 7FFF <sub>H</sub><br><b>GPIO2_PUDEN</b> = 4000 <sub>H</sub><br><b>GPIO2_DRIVE1_CFG</b> = 7FFF <sub>H</sub> |
| 3        | 10 Mbps or 100 Mbps link activity<br>Blinking frequency: 4 Hz<br>Single color or dual color | 1000 Mbps link activity<br>Blinking frequency: 4 Hz<br>Single color or dual color | GPIO  | <b>GPIO2_ALTSEL0</b> = 43FF <sub>H</sub><br><b>GPIO2_PUDEN</b> = 7C00 <sub>H</sub><br><b>GPIO2_DRIVE1_CFG</b> = 03FF <sub>H</sub> |

#### EEPROM Detection Procedure (PS\_NOWAIT = 1<sub>B</sub>)

Boot loader configures the registers in the same way as Self-start mode procedure first (as shown in [Self-start Mode Procedure \(PS\\_NOWAIT = 1<sub>B</sub>\)](#)). After that, SPI master uses default low speed clock and 24-bit address mode to start. It uses SPI master manual mode and start to read the first six addresses of EEPROM. When the value in **MSPI\_DIN23** = 010101XX010101XX<sub>B</sub>, then most likely valid flash is attached. The address mode (**ADDRMD** in **MSPI\_CFG**) is set to the lower 2 bits of **MSPI\_DIN23**. After that, with the new addressing mode, read address 6 and 7 of the EEPROM. When the value of the address 6 is 10101010<sub>B</sub>, then it is confirmed that the flash is detected. Configure SPI master clock frequency (**CLKDIV** in **MSPI\_CFG**) to the value in the address 7 of the EEPROM. Finally the configuration in EEPROM is executed by boot loader.

#### EEPROM Applications

Connecting an external EEPROM is intentionally used to enable customers implementing systems without any management entity or STA. In such a system there is no STA driving the management interface and thus neither control nor configuration information is transferred as such. Also it is not possible to configure all functionality of the Gigabit Ethernet Switch solely using the pin-strapping interface. In such applications, the external EEPROM provides a low cost and efficient solution to store the whole configuration information required to be loaded by the Gigabit Ethernet Switch during startup.

The Gigabit Ethernet Switch supports EEPROM devices by means of SPI master interface.

In the simplest application the EEPROM is only used to store the configuration information of the Gigabit Ethernet Switch. This configuration is loaded by the Gigabit Ethernet Switch directly after reset or power-up when an EEPROM has been detected.

#### EEPROM Content

[Table 21](#) shows the EEPROM contents, which include EEPROM type record and configuration content records.

The start address for EEPROM type record is 0. There are 8 bytes in EEPROM type record. [Table 14](#) shows the format of EEPROM type record.

The start address for EEPROM configuration content record is 8.

[Table 21](#) shows the overall EEPROM content format.



**Table 15** to **Table 20** define configuration content record. It consists of multiple access blocks. For each access block, there are the following elements:

- Number of configuration entries. When it is 0, this is the last access block and no valid configuration for the last access block. When it is non-0, it represents the number of configuration entries in the current access block.
- Access Type
  - When it is 0000<sub>H</sub>, then the current access type is incremental access type. Only the address for the first access entry is stored in the EEPROM. See **Table 15**.
  - When it is FFFF<sub>H</sub>, then the current access type is single access without write enable type. The address for each access entry is stored in the EEPROM. See **Table 16**.
  - When it is 6666<sub>H</sub>, then the current access type is single access with write enable type. The address and the write enable for each access entry is stored in the EEPROM. This requires read-modify-write operation for each access entry. See **Table 17**.
  - When it is 9999<sub>H</sub>, then the current access type is “run self-start mode configuration”. The configuration is listed in **Self-start Mode Procedure (PS\_NOWAIT = 1<sub>B</sub>)**. See **Table 18**.
  - When it is 5555<sub>H</sub>, then the current access type is wait until true access. Boot loader polls a 16-bit register until its value after mask matches with the expected data. See **Table 19**.
  - When it is AAAA<sub>H</sub>, then the current access type is conditional jump access. Boot load reads a 16-bit register, when its value after mask matches with the expected data, boot loader jumps to a new location. The new location relative offset to the current address is programmable in the block. See **Table 20**.
- Optional: 16-bit Bus Address
- Single or Multiple 16-bit Data to be written or read
- Optional: 16-bit mask for read or enable for write
- Optional: The offset of the next address from the current address

**Table 14 EEPROM Type Record**

| Address <sup>1)</sup> | Content |   |   |   |   |   |                     |   | Comment  |
|-----------------------|---------|---|---|---|---|---|---------------------|---|--|
|                       | 7       | 6 | 5 | 4 | 3 | 2 | 1                   | 0 |  |
| 0                     | 0       | 1 | 0 | 1 | 0 | 1 | EEPROM Address Mode |   | Identify EEPROM and EEPROM Address Mode<br>EEPROM Address Mode:<br><b>Constants</b><br>00 <sub>B</sub> <b>9-bit</b> SPI master interface is in 9-bit address mode.<br>01 <sub>B</sub> <b>16-bit</b> SPI master interface is in 16/17-bit address mode.<br>10 <sub>B</sub> <b>24-bit</b> SPI master interface is in 24-bit address mode.<br>11 <sub>B</sub> <b>24H-bit</b> SPI master interface is in 24-bit high speed address mode. |
| 1                     | 0       | 1 | 0 | 1 | 0 | 1 | EEPROM Address Mode |   |  |
| 2                     | 0       | 1 | 0 | 1 | 0 | 1 | EEPROM Address Mode |   |  |
| 3                     | 0       | 1 | 0 | 1 | 0 | 1 | EEPROM Address Mode |   |  |
| 4                     | 1       | 0 | 1 | 0 | 1 | 0 | 1                   | 0 | Check Value  |
| 5                     | CLKDIV  |   |   |   |   |   |                     |   | Master SPI Clock is<br>62.5 MHz/(CLKDIV+1)   |
| 6                     | 0       | 0 | 0 | 0 | 0 | 0 | 0                   | 0 |  |
| 7                     | 0       | 0 | 0 | 0 | 0 | 0 | 0                   | 0 |  |

1) This is the byte-wise EEPROM address. This scheme is independent of the used address mode.

**Table 15 Configuration Content Record: Incremental Access Format**

| Address <sup>1)</sup>     | Content             |   |   |   |   |   |   |   | Comment  |
|---------------------------|---------------------|---|---|---|---|---|---|---|--|
|                           | 7                   | 6 | 5 | 4 | 3 | 2 | 1 | 0 |  |
| Incremental Access Format |                     |   |   |   |   |   |   |   |  |
| 0                         | NOCE[15:8]          |   |   |   |   |   |   |   | Number of Configuration Entries. A value of 00 <sub>H</sub> corresponds to 0 entry. A value of FFFF <sub>H</sub> corresponds to 65535 entries. |
| 1                         | NOCE[7:0]           |   |   |   |   |   |   |   |  |
| 2                         | 0                   | 0 | 0 | 0 | 0 | 0 | 0 | 0 | 0000 <sub>H</sub> = Incremental Access Type  |
| 3                         | 0                   | 0 | 0 | 0 | 0 | 0 | 0 | 0 |  |
| 4                         | ADDR(0)[15:8]       |   |   |   |   |   |   |   | PDI Bus Address and Configuration-Data for Entry 0   |
| 5                         | ADDR(0)[7:0]        |   |   |   |   |   |   |   |  |
| 6                         | DATA(0)[15:8]       |   |   |   |   |   |   |   |  |
| 7                         | DATA(0)[7:0]        |   |   |   |   |   |   |   |  |
| 8                         | DATA(1)[15:8]       |   |   |   |   |   |   |   | PDI Bus Configuration-Data Word for Entry 1  |
| 9                         | DATA(1)[7:0]        |   |   |   |   |   |   |   |  |
| ...                       | ...                 |   |   |   |   |   |   |   | ...  |
| 6+2*(NOCE-1)              | DATA(NOCE-1)[15:8]. |   |   |   |   |   |   |   | PDI Bus Configuration-Data Word for Entry #NOCE -1   |
| 7+2*(NOCE-1)              | DATA(NOCE-1)[7:0]   |   |   |   |   |   |   |   |  |

1) This is the byte-wise EEPROM address. This scheme is independent of the used address mode.

**Table 16 Configuration Content Record: Single Access without Write Enable Format**

| Address <sup>1)</sup>                     | Content       |   |   |   |   |   |   |   | Comment  |
|---|---------------|---|---|---|---|---|---|---|--|
|   | 7             | 6 | 5 | 4 | 3 | 2 | 1 | 0 |  |
| Single Access Without Write Enable Format |               |   |   |   |   |   |   |   |  |
| 0   | NOCE[15:8]    |   |   |   |   |   |   |   | Number of Configuration Entries. A value of 00 <sub>H</sub> corresponds to 0 entry. A value of FFFF <sub>H</sub> corresponds to 65535 entries. |
| 1   | NOCE[7:0]     |   |   |   |   |   |   |   |  |
| 2   | 1             | 1 | 1 | 1 | 1 | 1 | 1 | 1 | FFFF <sub>H</sub> = Single Access Without Write Enable Type  |
| 3   | 1             | 1 | 1 | 1 | 1 | 1 | 1 | 1 |  |
| 4   | ADDR(0)[15:8] |   |   |   |   |   |   |   | PDI Bus Address and Configuration-Data for Entry 0   |
| 5   | ADDR(0)[7:0]  |   |   |   |   |   |   |   |  |
| 6   | DATA(0)[15:8] |   |   |   |   |   |   |   |  |
| 7   | DATA(0)[7:0]  |   |   |   |   |   |   |   |  |
| 8   | ADDR(1)[15:8] |   |   |   |   |   |   |   | PDI Bus Address and Configuration-Data for Entry 1   |
| 9   | ADDR(1)[7:0]  |   |   |   |   |   |   |   |  |
| 10  | DATA(1)[15:8] |   |   |   |   |   |   |   |  |
| 11  | DATA(1)[7:0]  |   |   |   |   |   |   |   |  |
| ...                                       | ...           |   |   |   |   |   |   |   | ...  |

**Table 16 Configuration Content Record: Single Access without Write Enable Format (cont'd)**

| Address <sup>1)</sup> | Content            |   |   |   |   |   |   |   | Comment  |
|-----------------------|--------------------|---|---|---|---|---|---|---|--|
|                       | 7                  | 6 | 5 | 4 | 3 | 2 | 1 | 0 |  |
| 4 + 4*(NOCE-1)        | ADDR(NOCE-1)[15:8] |   |   |   |   |   |   |   | PDI Bus Address and Configuration-Data for Entry #NOCE-1 |
| 5 + 4*(NOCE-1)        | ADDR(NOCE-1)[7:0]  |   |   |   |   |   |   |   |  |
| 6 + 4*(NOCE-1)        | DATA(NOCE-1)[15:8] |   |   |   |   |   |   |   |  |
| 7 + 4*(NOCE-1)        | DATA(NOCE-1)[7:0]  |   |   |   |   |   |   |   |  |

1) This is the byte-wise EEPROM address. This scheme is independent of the used address mode.

**Table 17 Configuration Content Record: Single Write Access with Write Enable Format**

| Address <sup>1)</sup>                  | Content            |   |   |   |   |   |   |   | Comment   |
|--|--------------------|---|---|---|---|---|---|---|---|
|  | 7                  | 6 | 5 | 4 | 3 | 2 | 1 | 0 |   |
| Single Access With Write Enable Format |                    |   |   |   |   |   |   |   |   |
| 0                                      | NOCE[15:8]         |   |   |   |   |   |   |   | Number of Configuration Entries. A value of 00 <sub>H</sub> corresponds to 0 entry. A value of FFFF <sub>H</sub> corresponds to 65535 entries.  |
| 1                                      | NOCE[7:0]          |   |   |   |   |   |   |   |   |
| 2                                      | 0                  | 1 | 1 | 0 | 0 | 1 | 1 | 0 | 6666 <sub>H</sub> = Single Access With Write Enable Type  |
| 3                                      | 0                  | 1 | 1 | 0 | 0 | 1 | 1 | 0 |   |
| 4                                      | ADDR(0)[15:8]      |   |   |   |   |   |   |   | PDI Bus Address, Configuration-Data and Write Enable for Entry 0<br>This requires read-modify-write.<br>Write Enable  |
| 5                                      | ADDR(0)[7:0]       |   |   |   |   |   |   |   |   |
| 6                                      | DATA(0)[15:8]      |   |   |   |   |   |   |   | <b>Constants</b><br>0 <sub>B</sub> <b>DIS</b> Don't Modify the Bit.<br>1 <sub>B</sub> <b>EN</b> Modify the Bit.   |
| 7                                      | DATA(0)[7:0]       |   |   |   |   |   |   |   |   |
| 8                                      | WE(0)[15:8]        |   |   |   |   |   |   |   | PDI Bus Address, Configuration-Data and Write Enable for Entry 1<br>This requires read-modify-write.<br>Write Enable<br><b>Constants</b><br>0 <sub>B</sub> <b>DIS</b> Don't Modify the Bit.<br>1 <sub>B</sub> <b>EN</b> Modify the Bit.       |
| 9                                      | WE(0)[7:0]         |   |   |   |   |   |   |   |   |
| 10                                     | ADDR(1)[15:8]      |   |   |   |   |   |   |   | PDI Bus Address, Configuration-Data and Write Enable for Entry 1<br>This requires read-modify-write.<br>Write Enable<br><b>Constants</b><br>0 <sub>B</sub> <b>DIS</b> Don't Modify the Bit.<br>1 <sub>B</sub> <b>EN</b> Modify the Bit.       |
| 11                                     | ADDR(1)[7:0]       |   |   |   |   |   |   |   |   |
| 12                                     | DATA(1)[15:8]      |   |   |   |   |   |   |   | PDI Bus Address, Configuration-Data and Write Enable for Entry #NOCE-1<br>This requires read-modify-write.<br>Write Enable<br><b>Constants</b><br>0 <sub>B</sub> <b>DIS</b> Don't Modify the Bit.<br>1 <sub>B</sub> <b>EN</b> Modify the Bit. |
| 13                                     | DATA(1)[7:0]       |   |   |   |   |   |   |   |   |
| 14                                     | WE(1)[15:8]        |   |   |   |   |   |   |   | PDI Bus Address, Configuration-Data and Write Enable for Entry #NOCE-1<br>This requires read-modify-write.<br>Write Enable<br><b>Constants</b><br>0 <sub>B</sub> <b>DIS</b> Don't Modify the Bit.<br>1 <sub>B</sub> <b>EN</b> Modify the Bit. |
| 15                                     | WE(1)[7:0]         |   |   |   |   |   |   |   |   |
| ...                                    | ...                |   |   |   |   |   |   |   | ...   |
| 4 + 6*(NOCE-1)                         | ADDR(NOCE-1)[15:8] |   |   |   |   |   |   |   | PDI Bus Address, Configuration-Data and Write Enable for Entry #NOCE-1<br>This requires read-modify-write.<br>Write Enable<br><b>Constants</b><br>0 <sub>B</sub> <b>DIS</b> Don't Modify the Bit.<br>1 <sub>B</sub> <b>EN</b> Modify the Bit. |
| 5 + 6*(NOCE-1)                         | ADDR(NOCE-1)[7:0]  |   |   |   |   |   |   |   |   |
| 6 + 6*(NOCE-1)                         | DATA(NOCE-1)[15:8] |   |   |   |   |   |   |   |   |
| 7 + 6*(NOCE-1)                         | DATA(NOCE-1)[7:0]  |   |   |   |   |   |   |   |   |
| 8 + 6*(NOCE-1)                         | WE(NOCE-1)[15:8]   |   |   |   |   |   |   |   | PDI Bus Address, Configuration-Data and Write Enable for Entry #NOCE-1<br>This requires read-modify-write.<br>Write Enable<br><b>Constants</b><br>0 <sub>B</sub> <b>DIS</b> Don't Modify the Bit.<br>1 <sub>B</sub> <b>EN</b> Modify the Bit. |
| 9 + 6*(NOCE-1)                         | WE(NOCE-1)[7:0]    |   |   |   |   |   |   |   |   |

1) This is the byte-wise EEPROM address. This scheme is independent of the used address mode.

**Table 18 Configuration Content Record: Run Self-start Mode Configuration Format**

| Address <sup>1)</sup>                    | Content    |   |   |   |   |   |   |   | Comment   |
|--|------------|---|---|---|---|---|---|---|---|
|  | 7          | 6 | 5 | 4 | 3 | 2 | 1 | 0 |   |
| Run Self Start Mode Configuration Format |            |   |   |   |   |   |   |   |   |
| 0  | NOCE[15:8] |   |   |   |   |   |   |   | Any Value /= 0  |
| 1  | NOCE[7:0]  |   |   |   |   |   |   |   |   |
| 2  | 1          | 0 | 0 | 1 | 1 | 0 | 0 | 1 | 9999 <sub>H</sub> = Run Self Start Mode Configuration |
| 3  | 1          | 0 | 0 | 1 | 1 | 0 | 0 | 1 |   |

1) This is the byte-wise EEPROM address. This scheme is independent of the used address mode.

**Table 19 Configuration Content Record: Wait Until True Format**

| Address <sup>1)</sup>         | Content    |   |   |   |   |   |   |   | Comment  |
|-------------------------------|------------|---|---|---|---|---|---|---|--|
|                               | 7          | 6 | 5 | 4 | 3 | 2 | 1 | 0 |  |
| Wait Until True Access Format |            |   |   |   |   |   |   |   |  |
| 0                             | NOCE[15:8] |   |   |   |   |   |   |   | Any Value /= 0   |
| 1                             | NOCE[7:0]  |   |   |   |   |   |   |   |  |
| 2                             | 0          | 1 | 0 | 1 | 0 | 1 | 0 | 1 | 5555 <sub>H</sub> = Wait Until True Access   |
| 3                             | 0          | 1 | 0 | 1 | 0 | 1 | 0 | 1 |  |
| 4                             | ADDR[15:8] |   |   |   |   |   |   |   | Register Address   |
| 5                             | ADDR[7:0]  |   |   |   |   |   |   |   |  |
| 6                             | DATA[15:8] |   |   |   |   |   |   |   | Expected Data  |
| 7                             | DATA[7:0]  |   |   |   |   |   |   |   |  |
| 8                             | MASK[15:8] |   |   |   |   |   |   |   | Comparison Mask<br><b>Constants</b><br>0 <sub>B</sub> <b>DIS</b> Don't Compare.<br>1 <sub>B</sub> <b>EN</b> Compare. |
| 9                             | MASK[7:0]  |   |   |   |   |   |   |   |  |

1) This is the byte-wise EEPROM address. This scheme is independent of the used address mode.

**Table 20 Configuration Content Record: Conditional Jump Access Format**

| Address <sup>1)</sup>          | Content    |   |   |   |   |   |   |   | Comment                                     |
|--------------------------------|------------|---|---|---|---|---|---|---|---|
|                                | 7          | 6 | 5 | 4 | 3 | 2 | 1 | 0 |   |
| Conditional Jump Access Format |            |   |   |   |   |   |   |   |   |
| 0                              | NOCE[15:8] |   |   |   |   |   |   |   | Any Value /= 0                              |
| 1                              | NOCE[7:0]  |   |   |   |   |   |   |   |   |
| 2                              | 1          | 0 | 1 | 0 | 1 | 0 | 1 | 0 | AAAA <sub>H</sub> = Conditional Jump Access |
| 3                              | 1          | 0 | 1 | 0 | 1 | 0 | 1 | 0 |   |
| 4                              | ADDR[15:8] |   |   |   |   |   |   |   | Register Address                            |
| 5                              | ADDR[7:0]  |   |   |   |   |   |   |   |   |
| 6                              | DATA[15:8] |   |   |   |   |   |   |   | Expected Data                               |
| 7                              | DATA[7:0]  |   |   |   |   |   |   |   |   |

**Table 20 Configuration Content Record: Conditional Jump Access Format (cont'd)**

| Address <sup>1)</sup> | Content      |   |   |   |   |   |   |   | Comment   |
|-----------------------|--------------|---|---|---|---|---|---|---|---|
|                       | 7            | 6 | 5 | 4 | 3 | 2 | 1 | 0 |   |
| 8                     | MASK[15:8]   |   |   |   |   |   |   |   | Comparison Mask   |
| 9                     | MASK[7:0]    |   |   |   |   |   |   |   | <b>Constants</b><br>0 <sub>B</sub> <b>DIS</b> Don't Compare.<br>1 <sub>B</sub> <b>EN</b> Compare. |
| A                     | OFFSET[15:8] |   |   |   |   |   |   |   | Next Address =  |
| B                     | OFFSET[7:0]  |   |   |   |   |   |   |   | Next EEPROM Address of<br>OFFSET[7:0] + OFFSET[15:0]*2<br>OFFSET is a signed integer.             |

1) This is the byte-wise EEPROM address. This scheme is independent of the used address mode.

**Table 21 EEPROM Content Format**

| Address Range | Content                      | Comment                                |
|---------------|------------------------------|--|
| 0 to 7        | EEPROM Type Record           | Identify EEPROM Address Mode and Speed |
| 8 to ...      | Configuration Content Record | Boot loader                            |

### Pin Strapping

This section describes the configuration of the device by means of pin strapping. As can be seen, the pin strapping functionality shares the LED pins, SPI and TDO signals.

Internal pull up for the pin strapping must be disabled after reset.

[Table 22](#) and [Table 23](#) list the pin-strapping mapping.

All GPIO pins are sampled at the rising edge of HRSTN and stored in registers PS0 and PS1. These two registers can only be reset by hardware reset.

PLL must be released from reset state some cycles after the rising edge of HRSTN (so that pin strapping occurs and be stable before PLL is released).

**Table 22 Functional Mode Pin Strapping**

| Pin Strap      | Description    |
|----------------|----------------|
| PS0(3): UTXD   | PS_XTAL        |
| PS0(7): MSDO   | PS_OP_MD1      |
| PS0(8): MSCK   | PS_SUBTYPE_MD3 |
| PS0(9): MSCS   | PS_SUBTYPE_MD4 |
| PS1(10): LED02 | PS_NOWAIT      |
| PS1(11): LED12 | PS_OP_MD0      |
| PS1(12): LED22 | PS_SUBTYPE_MD0 |
| PS1(13): LED32 | PS_SUBTYPE_MD1 |
| PS1(14): LED42 | PS_SUBTYPE_MD2 |

**Table 23 Pin Strapping Description**

| Pin Strapping Signals | Description  |
|-----------------------|--|
| PS_XTAL               | <b>XTAL Frequency</b><br>This is to specify the frequency of XTAL.<br>0 <sub>B</sub> <b>40 MHz</b> 40 MHz<br>1 <sub>B</sub> <b>25 MHz</b> 25 MHz   |
| PS_NOWAIT             | <b>No Wait for External Master Trigger</b><br>This is to specify whether the boot loader waits for the external master to trigger the start.<br>0 <sub>B</sub> <b>WAIT</b> Boot loader waits for external master to trigger the start of GPHY and GSWIP.<br>1 <sub>B</sub> <b>NOWAIT</b> Boot loader starts GPHY and GSWIP after the initialization is done. |
| PS_OP_MD              | <b>Operation Mode</b><br>This is to specify the chip operation mode.<br>00 <sub>B</sub> <b>OPMD0</b> Reserved<br>01 <sub>B</sub> <b>OPMD1</b> Standalone Unmanaged Switch.<br>10 <sub>B</sub> <b>OPMD2</b> Managed Switch with SPI Slave Interface.<br>11 <sub>B</sub> <b>OPMD3</b> Managed Switch with MDIO Slave Interface.                                |
| PS_SUBTYPE_MD         | <b>SUB Type Mode</b><br>See <a href="#">Table 24</a> .   |

**Table 24 SUBTYPE Mode Configuration**

| Operation Mode                           | SUBTYPE Mode  |
|--|---|
| OPMD1:<br>Standalone Unmanaged<br>Switch | PS_SUBTYPE_MD[4:3]:<br>00 <sub>B</sub> <b>MD0</b> LED Display Mode 0<br>01 <sub>B</sub> <b>MD1</b> LED Display Mode 1<br>10 <sub>B</sub> <b>MD2</b> LED Display Mode 2<br>11 <sub>B</sub> <b>MD3</b> LED Display Mode 3 |
|  | PS_SUBTYPE_MD[2]:<br>0 <sub>B</sub> <b>AUTO</b> Auto-polling to determine RGMII5 link status.<br>1 <sub>B</sub> <b>FORCE</b> Force RGMII5 link speed to 1G, full duplex and on.   |
|  | PS_SUBTYPE_MD[1]:<br>Reserved   |
|  | PS_SUBTYPE_MD[0]:<br>0 <sub>B</sub> <b>DIS</b> Disable RGMII5 interface.<br>1 <sub>B</sub> <b>EN</b> Enable RGMII5 interface.   |

**Table 24 SUBTYPE Mode Configuration (cont'd)**

| Operation Mode  | SUBTYPE Mode  |
|---|---|
| OPMD2:<br>Managed Switch with<br>SPI Slave Interface  | PS_SUBTYPE_MD[4]:<br>0 <sub>B</sub> <b>RXDLY0</b> RGMII Path RX Delay is 0 ns.<br>1 <sub>B</sub> <b>RXDLY2</b> RGMII Path RX Delay is 2 ns.   |
|   | PS_SUBTYPE_MD[3]:<br>0 <sub>B</sub> <b>TXDLY0</b> RGMII Path TX Delay is 0 ns.<br>1 <sub>B</sub> <b>TXDLY2</b> RGMII Path TX Delay is 2 ns.   |
|   | PS_SUBTYPE_MD[2]:<br>0 <sub>B</sub> <b>1G</b> SGMII Interface is 1 Gbps, MAC mode and Auto-neg disabled.<br>1 <sub>B</sub> <b>2.5G</b> SGMII Interface is 2.5 Gbps, MAC mode and Auto-neg disabled                      |
|   | PS_SUBTYPE_MD[1]:<br>SSPI SDI Edge Select<br>0 <sub>B</sub> <b>RISE</b> Sample at rising edge<br>1 <sub>B</sub> <b>FALL</b> Sample at falling edge  |
|   | PS_SUBTYPE_MD[0]<br>SSPI SDO Edge Select<br>0 <sub>B</sub> <b>RISE</b> Drive at rising edge<br>1 <sub>B</sub> <b>FALL</b> Drive at falling edge   |
| OPMD3:<br>Managed Switch with<br>MDIO Slave Interface | PS_SUBTYPE_MD[4]:<br>0 <sub>B</sub> <b>RXDLY0</b> RGMII Path RX Delay is 0 ns.<br>1 <sub>B</sub> <b>RXDLY2</b> RGMII Path RX Delay is 2 ns.   |
|   | PS_SUBTYPE_MD[3]:<br>0 <sub>B</sub> <b>TXDLY0</b> RGMII Path TX Delay is 0 ns.<br>1 <sub>B</sub> <b>TXDLY2</b> RGMII Path TX Delay is 2 ns.   |
|   | PS_SUBTYPE_MD[2]:<br>0 <sub>B</sub> <b>1G</b> SGMII interface is 1 Gbps, MAC mode and Auto-neg disabled.<br>1 <sub>B</sub> <b>2.5G</b> SGMII Interface is 2.5 Gbps, MAC mode and Auto-neg disabled.                     |
|   | PS_SUBTYPE_MD[1:0]:<br>00 <sub>B</sub> <b>0</b> SMDIO Address is 0.<br>01 <sub>B</sub> <b>4</b> SMDIO Address is 4.<br>10 <sub>B</sub> <b>16</b> SMDIO Address is 16.<br>11 <sub>B</sub> <b>31</b> SMDIO Address is 31. |

### 3.2.8 Packet Insertion and Extraction

An external controller is able to insert and extract the packets to/from the switch via port 6 of Gigabit Ethernet switch. When packet insertion/extraction mode is enabled (**PIE** = 1<sub>B</sub>), switch port 6 is connected to packet insertion/extraction module. This mode allows external CPU to insert/extract management/control packets without using RGMII interface.

In packet insertion/extraction mode, port 6 must be configured to 1000 Mbps, full duplex and pause disable mode. The link ok must be forced on.

For TX direction (packet extraction), when there is a new packet available, an interrupt is asserted. Interrupt status is cleared automatically when an external controller read **PKT\_EXT\_READ** register. When the AVAIL value is '1', then the data byte in the current read is the first byte of the packet and the data byte in the previous read is the last byte of the previous packet. When TXEN value of the read access is 0<sub>B</sub>, then the data byte in the previous read is the last byte of the packet.

An external controller can flush the rest of the packet after reading the packet header in packet extraction direction.

**Packet Insertion Programming Sequence**

- Write **PKT\_INS**:
  - **INSCMD** = 1<sub>B</sub>
  - **RXVD** = 0<sub>B</sub> or 1<sub>B</sub> depending when injecting interframe gap (**RXVD**=0<sub>B</sub>) or other types of data (including preamble, SFD and packet data, **RXVD**=1<sub>B</sub>).
  - **RXD** = the byte to be written.
- Repeat the above step for all the bytes in a packet (including IPG, Preamble, SFD). At least one interframe gap must be inserted so that the MAC can identify the end of packet and the start of the packet. At least one cycle between the two writes to **PKT\_INS** must be met.

**Packet Extraction Read Programming Sequence**

- Wait for interrupt.
- Read **PKT\_EXT\_READ** register.
- When **TXEN** is 1<sub>B</sub>, then the data byte is valid. When **TXEN** is 0<sub>B</sub>, then the data byte is not valid.
- When the previous read **TXEN** = 0<sub>B</sub>, the current read **TXEN** = 1<sub>B</sub> and the current read **AVAIL** = 1<sub>B</sub>, then current read data byte is the first byte of the packet (including preamble and SFD).
- When the previous read **TXEN** = 1<sub>B</sub> and the current read **TXEN** = 0<sub>B</sub> or current read **AVAIL** = 1<sub>B</sub>, then the previous read data byte is the last byte of the packet.
- Repeat reading until **TXEN** = 0<sub>B</sub> or current read **AVAIL** = 1<sub>B</sub> (EOP or SOP is detected). At least one cycle between the read reads to **PKT\_EXT\_READ** must be met.

**Packet Extraction Flush Programming Sequence**

- Write **PKT\_EXT\_CMD** to issue flush command (**FLUSH** = 1<sub>B</sub>).
- Wait for interrupt and check whether **AVAIL** in **PKT\_EXT\_CMD** is set for the next new packet.



### 3.3 LED Controller Function Description

#### 3.3.1 LED

LED pin 10, 20, 30 and TCK are multiplexed with JTAG interface. When TRSTN = '0', these 4 pins are used for GPIO/LED pins. When TRSTN = '1', these 4 pins are used for JTAG interface.

#### 3.3.2 LED Display

Each GPHY has 3 LEDs. The 3rd LED are used for pin strapping in the boot loader. All of them can be used as single color LED or dual color LED. When dual color LED is required in system, it is recommended to use the 3rd LED as one of the dual color LED to ease the pin-strapping circuit. The 3rd LED are used for pin strapping in the Boot ROM code.

Power LED is always in single color mode and multiplexed with GPIO pin. The value of power LED is directly configurable via GPIO output register.

For each LED in single color mode, it is either connecting external LED to ground or connecting external LED to power as shown in [Figure 11](#). It is configurable per LED to one of the mode via [LED\\_MD\\_CFG](#). For dual color LED, the corresponding field must be set to 0<sub>b</sub>. When LED is configured to power mode, then internal LED signal is inverted before feeding to the LED PAD. When LED is configured to power mode, both push-pull and open drain mode are supported via GPIO programming registers.

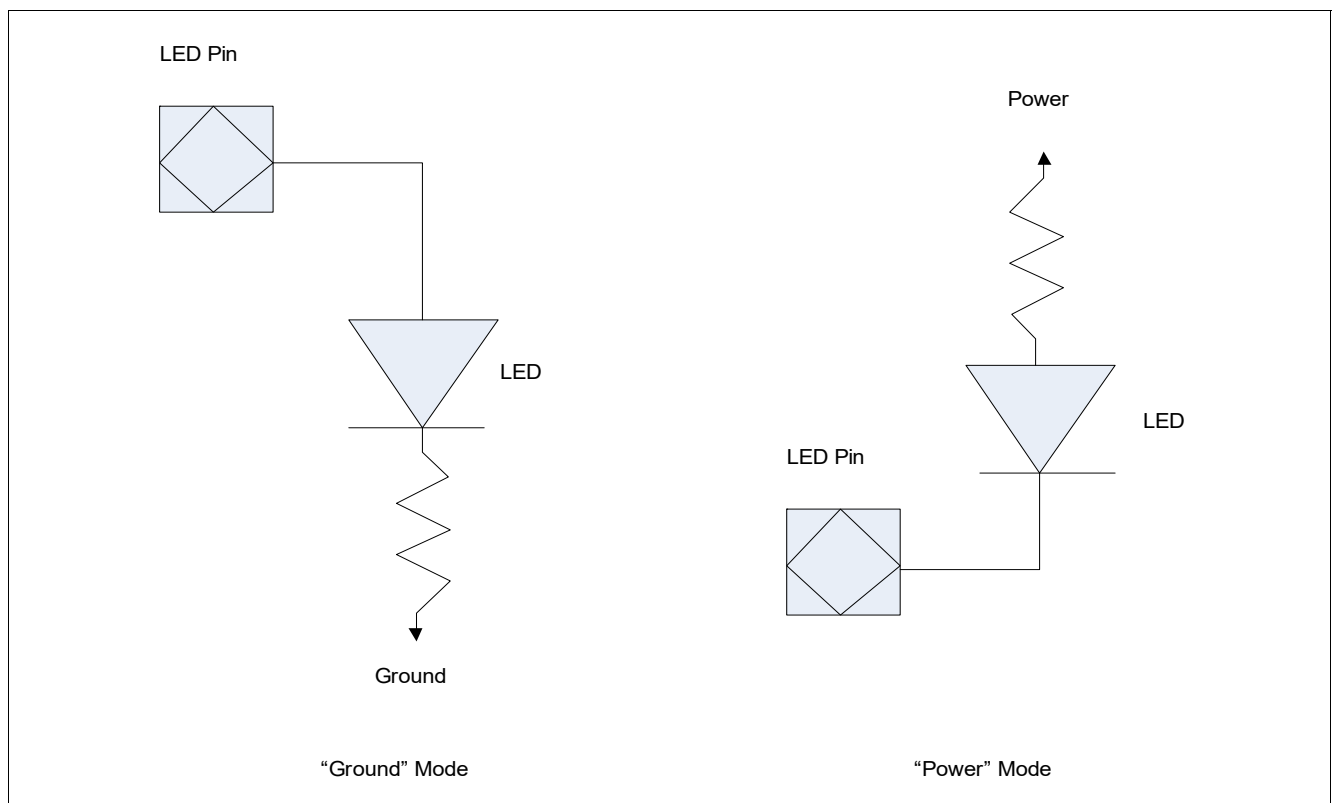

Figure 11 LED Display Mode

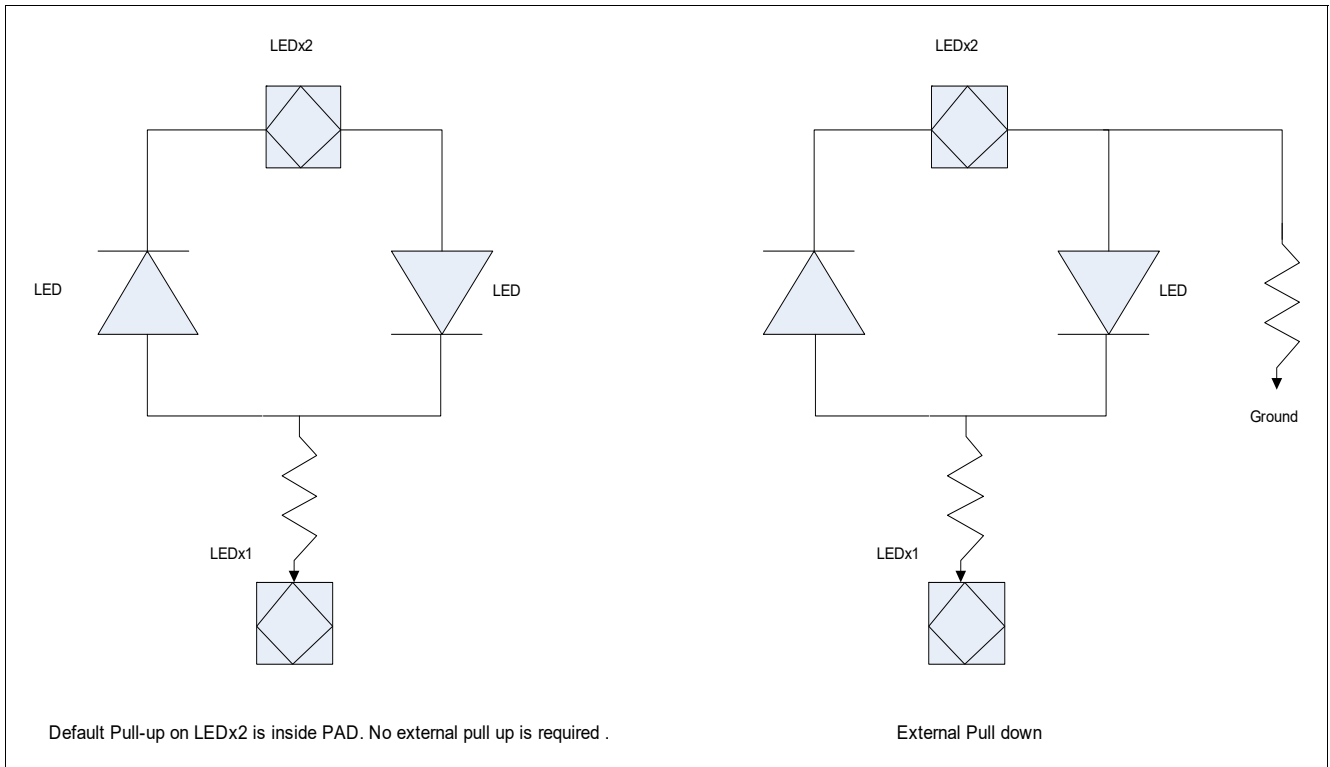

Figure 12 Pin Strapping on Dual Color LED

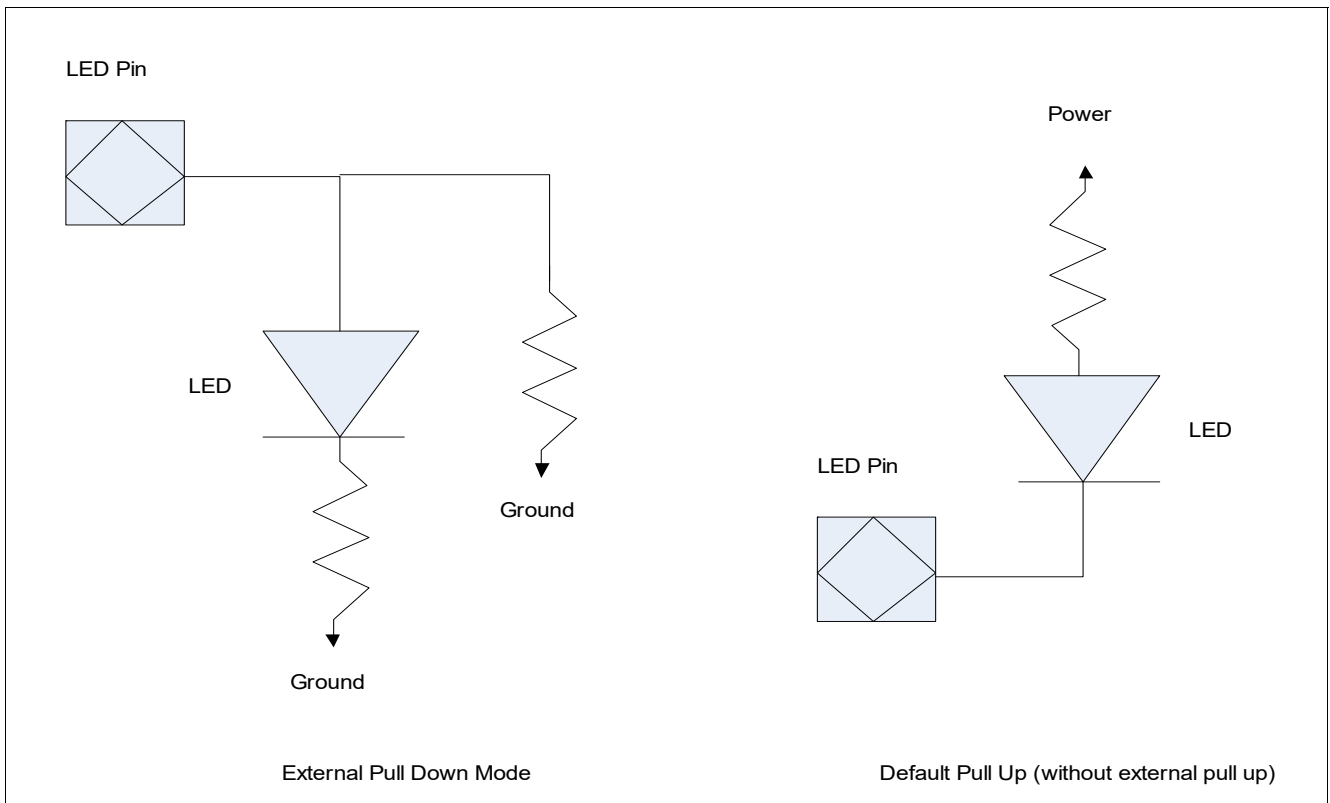

Figure 13 Pin Strapping on Single Color LED

### 3.3.3 LED Brightness Control

There are two brightness control mode. Either one of them can be used. The selection is determined by board design. They must not be used simultaneously.

- 2 Level Brightness Switch Mode
- 16 Level Light Sensor Control Mode

#### Brightness Control

This block controls the brightness of the LED by way of controlling the time duration the LED is ON/OFF, and due to persistence of the eye, LED brightness is perceived. When LED is off, the output is disabled. When LED is on, the output is enabled. Brightness control controls the LED output enable directly.

**Figure 14** shows the brightness control frequency is 100Hz. Each period is divided into 64 slots. LED brightness control is enabled/disabled via [LED\\_BRT\\_CTRL.EN](#).

When LED brightness control is disabled, LED is enabled in all 64 slots.

When LED brightness control is enabled, LED is enabled for consecutive n slots. n is determined by brightness level configured. LED output is disabled in the 64th slot. LED42 pin is in input mode during 64th slot and used to detect the rising/falling edge of external brightness switch input.

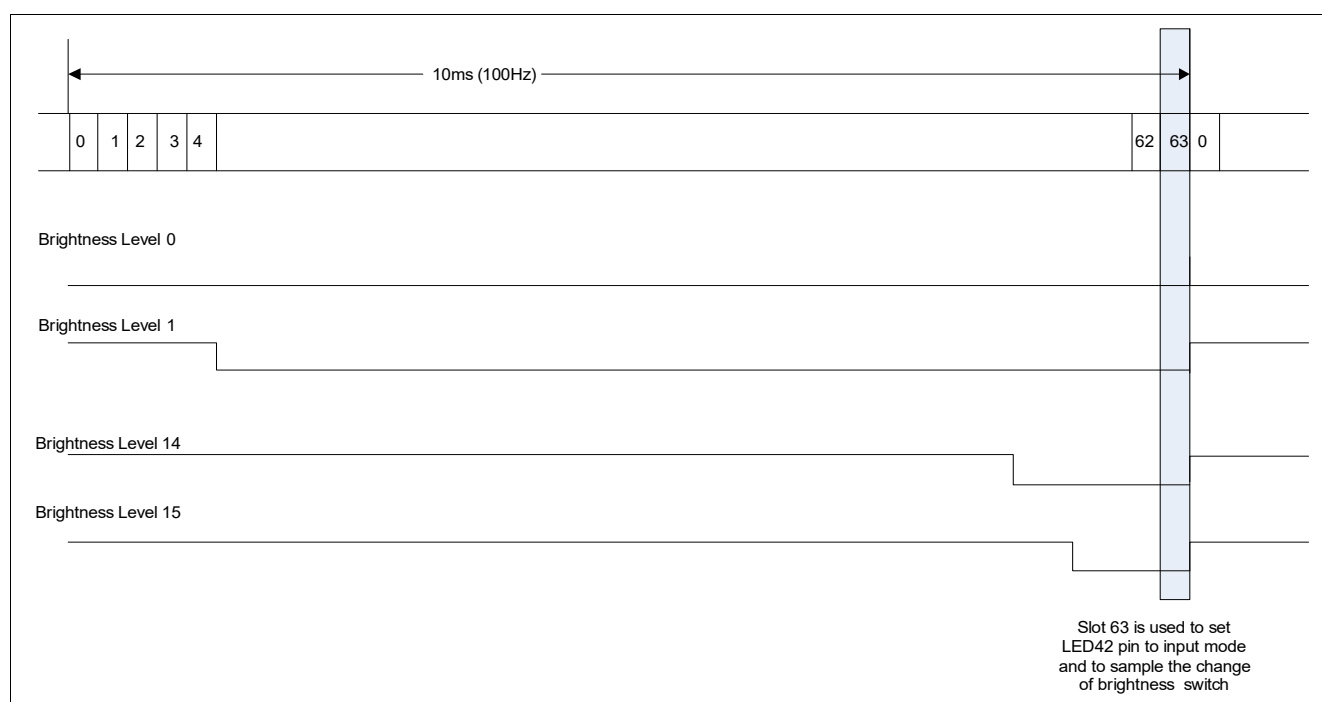

**Figure 14 LED Brightness Control By Controlling LED Output Enable/Disable**

#### 2 Level Brightness Switch Mode

LED42 pin is sampled at slot 63 to detect the toggling. The LED brightness is switched between two configurable brightness level ([LED\\_BRT\\_CTRL.MAXLEVEL](#), [LED\\_BRT\\_CTRL.MINLEVEL](#)).

This can be enabled/disabled via [LED\\_BRT\\_CTRL.2SEWN](#). When 2 level brightness switch mode is disabled, the brightness level is configured via [LED\\_BRT\\_CTRL.MAXLEVEL](#).

The spike on LED42 pin is filtered. Only when the value are stable for two consecutive sample after a change, the edge is considered as detected. The brightness must start with [LED\\_BRT\\_CTRL.MAXLEVEL](#). When LED42 pin is pulled up at pin strapping, then the falling edge of the sampling triggers the brightness toggle. When LED42 pin is pulled down, then the rising edge of the sampling triggers the brightness level toggle. The falling edge or rising edge trigger is selected via [LED\\_BRT\\_CTRL.EDGE](#).

When 2 level brightness switch control is disabled on system board, LED42 pin is either pull up or down externally (depending on pin strap option) to allow there is a constant, untoggled level on LED42 during the sample slot.

When 2 level LED brightness switch control is enabled on system board, an external recess switch is required to connect to LED42 pin.

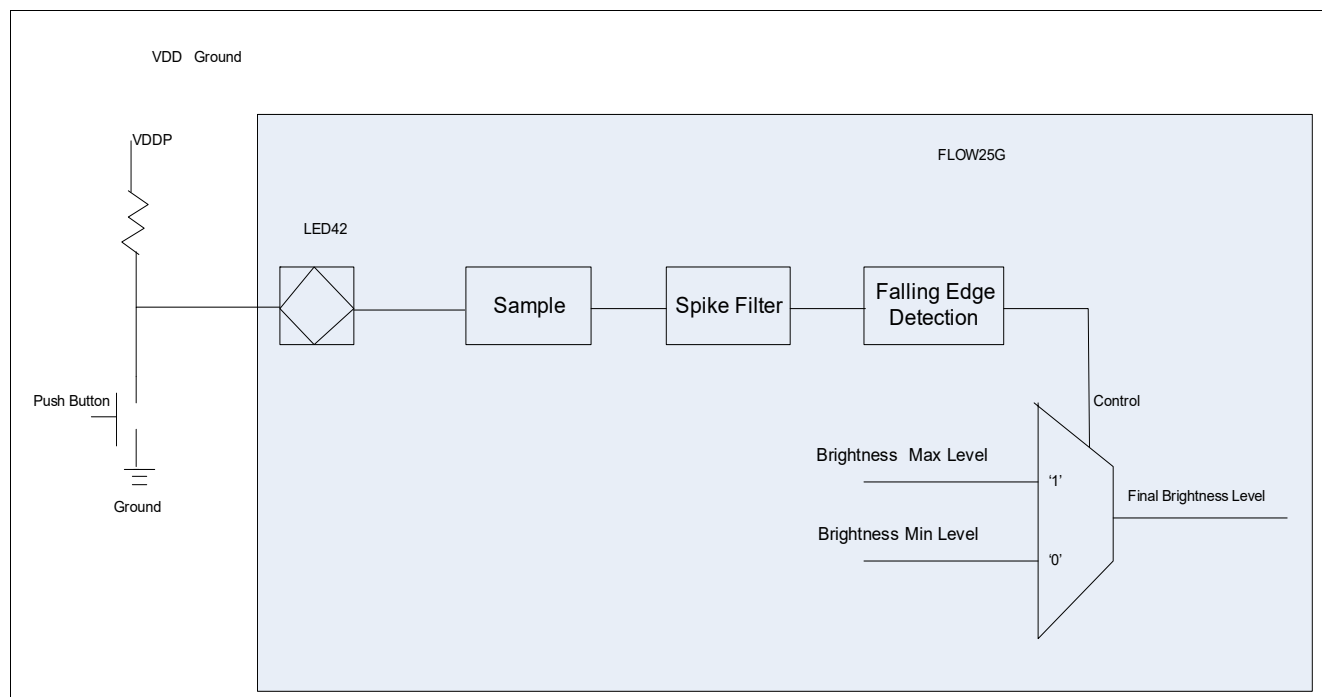

**Figure 15 Direct 2 Level LED Control Enable on System Board (with Pull-Up)**

### 16 Level Light Sensor Control Mode

In this mode, the brightness of LED dynamically varies depending on the light intensity. The light intensity is measured by a light sensor. This approach uses a constant current source (Visible Light Detector) and capacitor. The time it takes for the capacitor to charge to the given threshold voltage is linearly proportional to the charging current. The current is proportional to LUX value. One of GPIO pin is used for this purpose.

The sensing is repeated periodically. The period of the sensing is programmable via [LED\\_LSENS\\_CTRL.PERIOD](#). For each period, there are 256 slots. The first few slots are for discharging circuit. The number of slots for discharging is configurable via [LED\\_LSENS\\_CTRL.TD](#). After the discharging, the rising edge of the GPIO pin is detected. The number of slots from the end of discharging to the slot when the rising edge is detected ( $t - t_d$ ) is used to determine the light condition. There are 16 level of light condition, this 16 level light condition is converted to a 16-bit brightness level. Only when the difference between the sensed brightness level and the current brightness level is more than 1 (exception is when sensed brightness level is 1 and 15), the brightness is adjusted. Only 1 brightness level (+/-) can be adjusted from the current value. The brightness level must be within the range configured within [LED\\_BRT\\_CTRL.MINLEVEL](#), [LED\\_BRT\\_CTRL.MAXLEVEL](#).

When both [LED\\_BRT\\_CTRL.2SEWN](#) and [LED\\_LSENS\\_CTRL.SENS](#) are enabled, the final brightness level is the smaller value of the value determined by sensing logic and by the 2 Level LED switch logic.

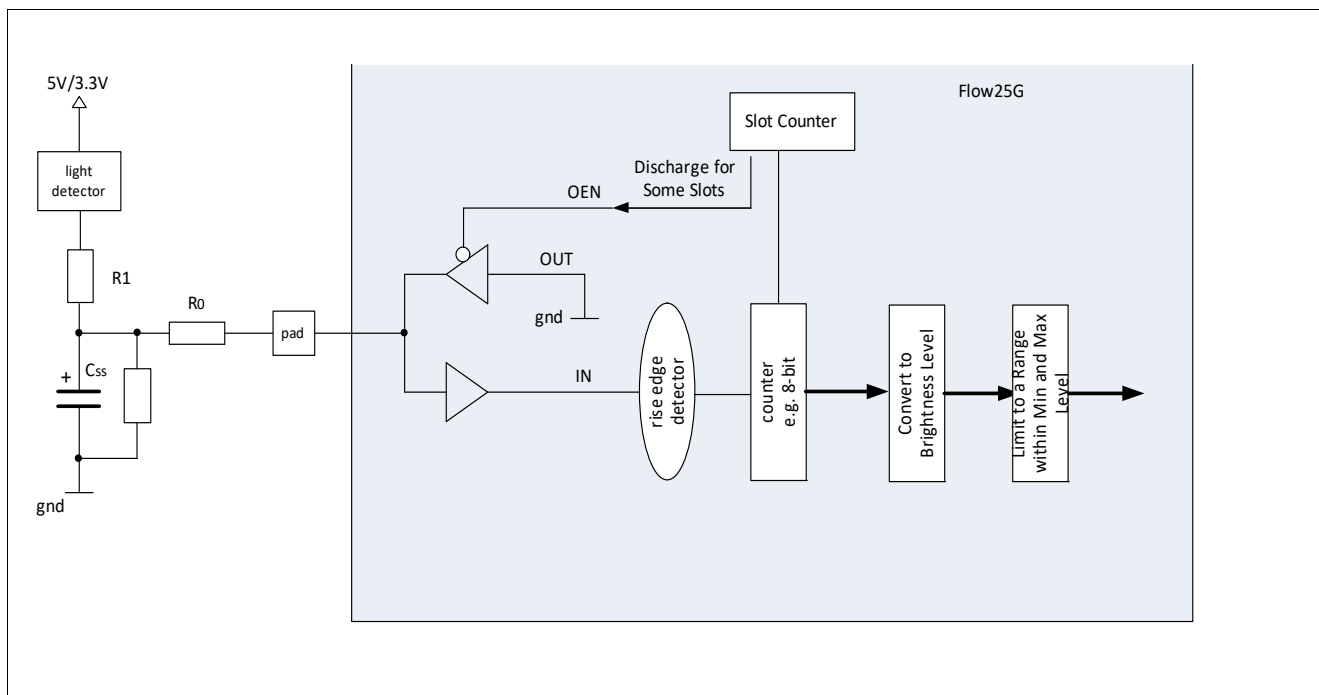

Figure 16 Light Sensing System

### 3.4 General Purpose Input Output Function Description

Figure 17 shows a general block diagram of a GPIO pin. Each GPIO pin is equipped with a number of control and data bits, enabling very flexible usage of the line.

Each GPIO pin can be configured for input or output operation. In input mode (default after reset), the output driver is switched off (high-impedance). The actual voltage level present at the port pin is translated into a logic 0 or 1 via a Schmitt-Trigger device and can be read via the read only register GPIO\_IN. In output mode, the output driver is activated and drives the value supplied through the multiplexer to the port pin. Switching between input and output mode is accomplished through the GPIO\_DIR register, which enables or disables the output driver.

The output multiplexer in front of the output driver enables the port output function to be used for different purposes. When the pin is used as general purpose output, the multiplexer is switched by software to the Output Data Register GPIO\_OUT. Software can set or clear the bit in GPIO\_OUT, and therefore it can directly influence the state of the port pin. When the on-chip peripheral units use the pin for output signals, alternate output lines can be switched via the multiplexer to the output driver circuitry.

Latch GPIO\_IN is provided for input functions of the on-chip peripheral units. Its input is connected to the output of the input Schmitt-Trigger. Further, an input signal can be connected directly to the various inputs of the peripheral units (AltDataIn). The function of the input line from the pin to the input latch GPIO\_IN and to AltDataIn is independent of the port pin operates as input or output. This means that when the port is in output mode, the level of the pin can be read by software via latch GPIO\_IN or a peripheral can use the pin level as an input. This offers additional advantages in an application.

- Each GPIO pin can also be programmed to activate an internal weak pull-up or pull-down device. Register GPIO\_PUDSEL selects whether a pull-up or the pull-down device is activated while register GPIO\_PUDEN enables or disables the pull devices.
- The data written to the output register GPIO\_OUT by software can be used as input data to an on-chip peripheral. This enables, for example, peripheral tests via software without external circuitry. Examples for this can be the triggering of a timer count input, generating an external interrupt, or simulating the incoming serial data stream to a serial port receive input via software.

- When the pin is used as an output, the actual logic level at the pin can be examined through reading latch GPIO\_IN and compared against the applied output level (either applied through software via the output register GPIO\_OUT, or via an alternate output function of a peripheral). This can be used to detect some electrical failures at the pin caused through external circuitry. In addition, software supported arbitration schemes can be implemented in this way using the open-drain configuration and an external wired-And circuitry. Collisions on the external communication lines can be detected when a logic 1 is output, but a logic 0 is seen when reading the pin value via the input latch GPIO\_IN.
- The output data from a peripheral applied to the pin via an alternate output function can be read through software or used by the same or another peripheral as input data. This enables testing of peripheral functions or provides additional connections between on-chip peripherals via the same pin without external wires.

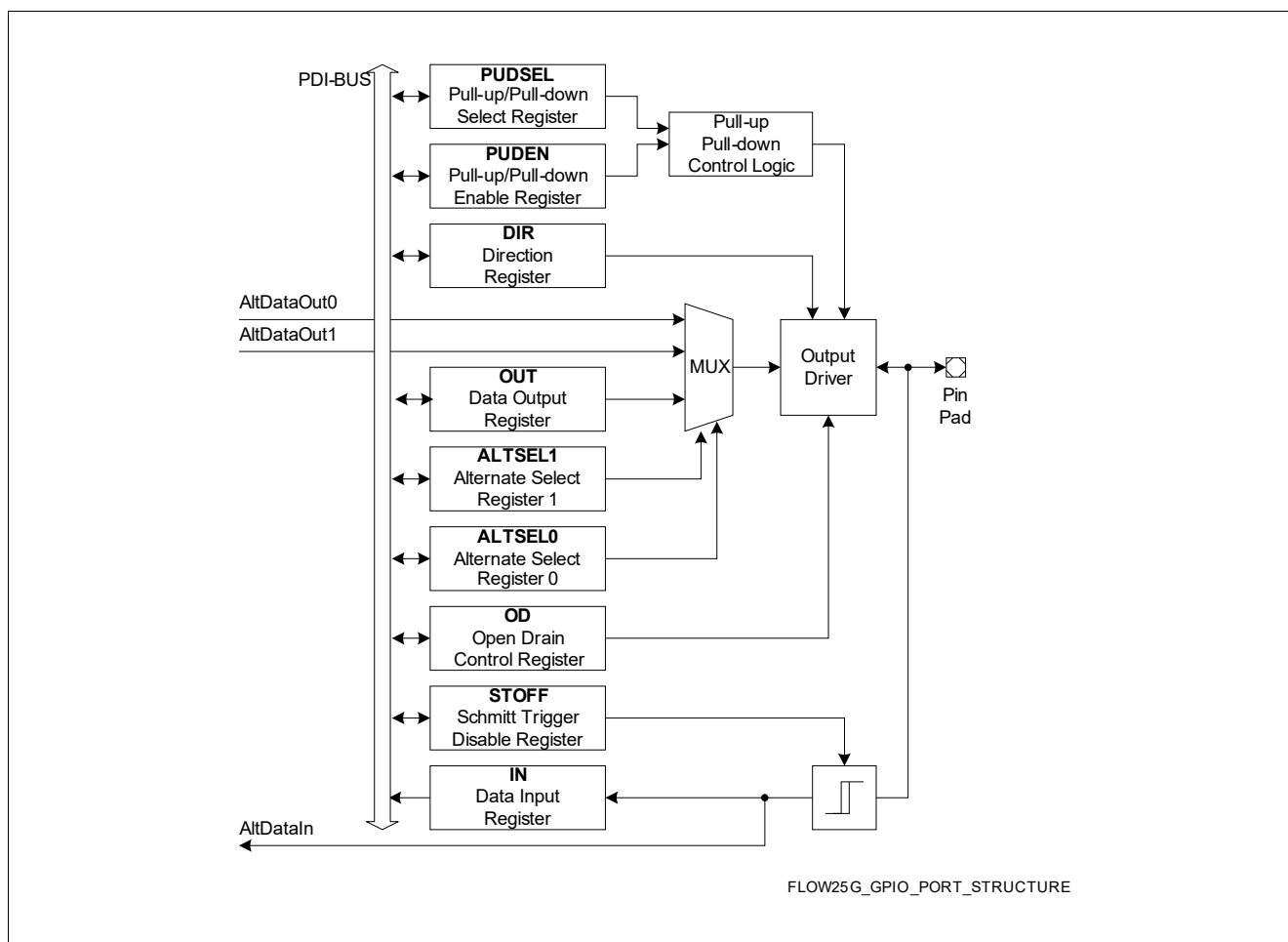

**Figure 17 General Port Structure**

The GPIO pins share with other alternative functions as shown in [Table 6](#) and [Table 7](#).

## 3.5 Gigabit Ethernet PHY Functional Description

### 3.5.1 Features

- Supports Energy-Efficient Ethernet (EEE):
  - 10BASE-Te
  - 100BASE-TX
  - 1000BASE-T
  - Power Down modes
  - Wake-on-LAN support
  - Integrated termination resistors
  - Supports transformerless Ethernet (TLE) for backplane applications
  - Low-EMI voltage mode line-driver
- Auto-negotiation with next-page support
- Auto-downspeed
- Auto-MDI/MDIX and Polarity selection
- Test Loops
- Cable diagnostics:
  - Cable open/short detection
  - Cable length estimation

### 3.5.2 Functional Description

#### 3.5.2.1 Twisted-Pair Interface

The Twisted-Pair Interface (TPI) of the GPHY IP is fully compliant with IEEE 802.3. To facilitate low-power implementation and reduce PCB costs, the series resistors required to terminate the twisted-pair link to nominally 100  $\Omega$  are integrated into the device.

As a consequence, the TPI pins can be directly connected via the transformer to the RJ45 plug. Additional external circuitry is only required for proper common-mode termination and rejection. [Figure 18](#) shows a high-level schematic of the TPI circuitry, taking these components into account.

GPHY IP supports normal operation with transformers whose center-taps on the chip side are shorted and connected to capacitors.

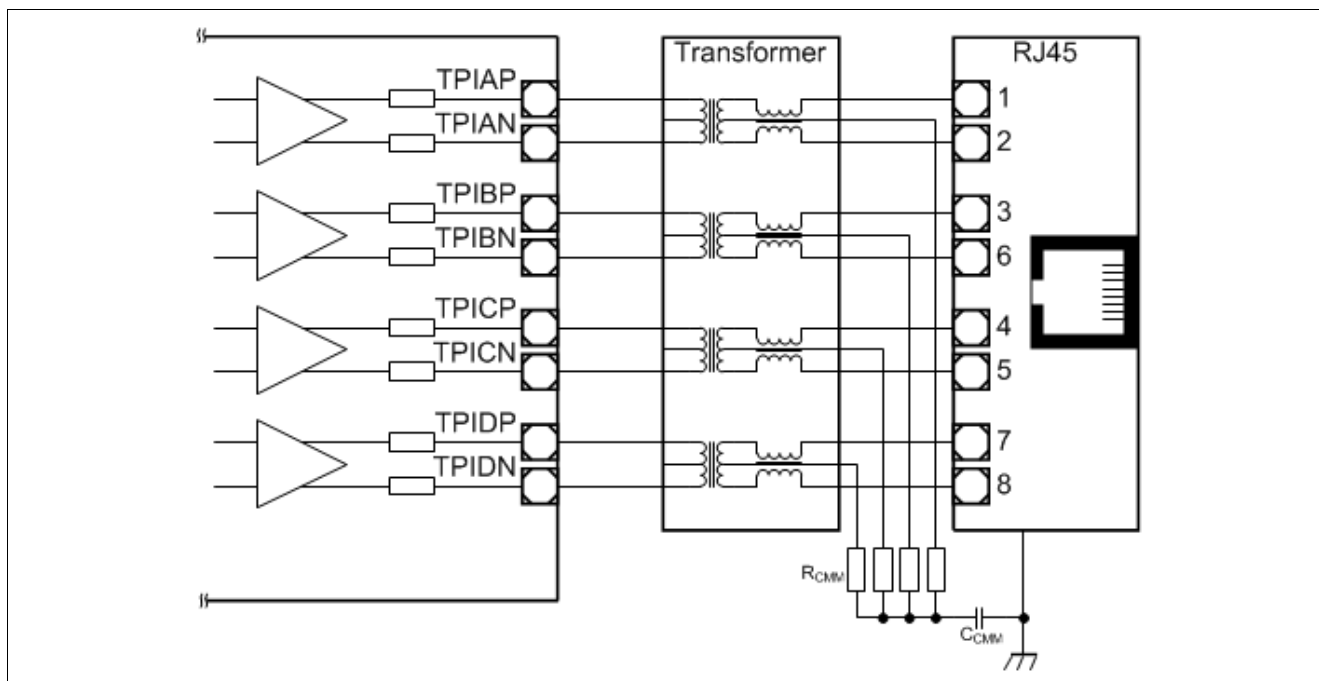

Figure 18 Twisted-Pair Interface of GPHY IP Including Transformer and RJ45 Plug

### 3.5.2.2 Auto-Negotiation (ANEG)

The GPHY IP supports Auto-Negotiation (ANEG) as a startup procedure to exchange capability information with the link partner.

Unless ANEG is manually disabled, the GPHY IP initiates each link-up using an ANEG procedure according to IEEE 802.3-2008 Clause 28 and essentially required for the 1000BASE-T mode in IEEE 802.3-2008 Clause 40.

Unless otherwise configured, the GPHY IP carries out an auto-crossover detect/enable procedure prior to the start of the ANEG process. This ensures optimal interoperability even in inadequate cable infrastructure environments. However, when ANEG is disabled, the auto-crossover procedure is still done during link-up.

The ANEG procedure implementation is compliant with standards given in IEEE 802.3-2008, clause 28. When the link partner does not support ANEG, the GPHY IP extracts the link-speed configuration using **parallel detection**. The GPHY IP supports Next Page (NP) exchange, since it is mandatory for advertising 1000BASE-T capabilities. By default, NPs are exchanged autonomously and do not require interaction with any management device.

### 3.5.2.3 Auto-Downspeed

The Auto-Downspeed (ADS) feature ensures maximum interoperability even in harsh or inadequate cable infrastructure environments. In particular, ADS is applied during 1000BASE-T training. This is necessary because the information available about the cabling during ANEG is insufficient. It is possible to advertise 1000BASE-T during ANEG, even though it might happen that both link partners are connected via a CAT-3 cable, which does not support the 4-pair Gigabit Ethernet mode.

To avoid continuous link-up failures in such a situation, the GPHY IP operates a detection algorithm to identify this situation. As a consequence, Gigabit-capability indication is cleared from the ANEG registers. After the resulting link-down, the next ANEG process does not advertise 1000BASE-T anymore, so that even when the link partner does not implement this kind of ADS algorithm, the next link-up is done at the next advertised speed below 1000 Mbps.

It can also happen that the existing cable infrastructure is adequate, but that the integrity of received signals is not suitable for a 1000BASE-T link-up, for example due to increased alien noise, or over-length cables. When such a condition is detected, the GPHY IP also does an ADS procedure.



Finally, it can also happen that, even though the GPHY IP is able to link up properly, for example in slave mode, the link partner is not able to. In this situation, ADS criterion described previously does not become active, but the link also never comes up. To address this corner situation, the GPHY IP counts the number of attempts to link up to 1000BASE-T. When this number is greater than 3, the ADS procedure is carried out. This number is reset internally after each successful 1000BASE-T link-up.

In all flow and mode settings that support only speeds of 1000 Mbps, the ADS feature is automatically disabled. The number of times GPHY IP decide to downspeed the link is counted and available as statistics via the MDIO.PHY.ERRCNT register.

### 3.5.2.4 Auto-Crossover and Polarity-Reversal Correction

To maximize interoperability even in inadequate wiring environments, the GPHY IP supports auto-crossover and polarity-reversal detection and correction. Both features are enabled by default.

Auto-crossover detection and correction operates at all supported twisted-pair speeds.

In 10BASE-T and 100BASE-TX, pairs C and D are not used. Consequently, modes 2 and 3 as well as 1 and 4 are identical.

In 1000BASE-T all modes are applicable.

The auto-crossover functionality is fully compliant with IEEE 802.3, clause 40.4.4, in 1000BASE-T mode. In the 10BASE-T and 100BASE-TX modes, this functionality depends on the detection of valid link pulses.

Polarity-reversal errors caused by improper wiring are automatically corrected by the GPHY IP. This correction is done on all pairs in the receive direction for all supported twisted-pair media modes. In 10BASE-T mode, the polarity correction is based on the detection of valid link pulses. In 100BASE-TX, the polarity of the receive signal is inherently corrected by the negation invariance of line code. In the 1000BASE-T mode, polarity detection is part of the training sequence. In all the modes, the detected polarity is frozen once the link has been established, and remains unchanged until the link is dropped.

### 3.5.2.5 Transformerless Ethernet (TLE)

Transformerless Ethernet (TLE) is required for back-plane or PICMG applications, where the use of a transformer (magnetics) is not necessarily required to fulfill the galvanic-decoupling requirements of the isolation specifications. In such applications, removing the transformer reduces both the external bill of materials and the space requirements on the PCB.

As the GPHY IP incorporates a novel type of voltage-mode line-driver, the only stringent requirement is to use AC coupling. AC coupling is achieved using simple SMD-type series capacitors, the value of which is selected so that the high-pass characteristics correspond to an equivalent transformer-based standard application (recommended  $C_{\text{coupling}} = 100 \text{ nF}$ ). **Figure 19** shows the TLE external circuitry. The RJ45 connector is shown only for illustration purposes. The back-plane applications use different connectors.

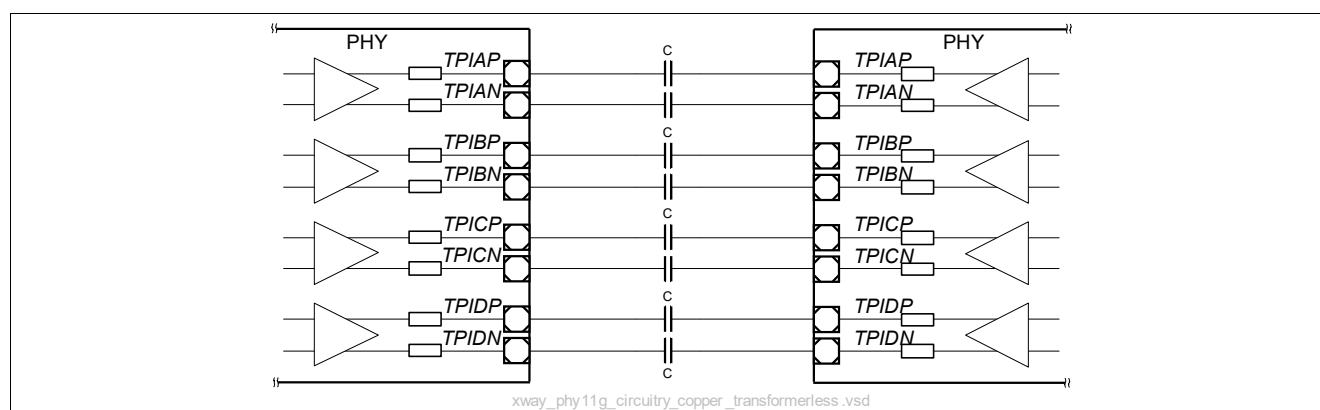

**Figure 19 External Circuitry for the Transformerless Ethernet Application**

### 3.5.2.6 Configuration and Control via MDIO

When a higher-level management entity exists in the system, this can configure and control the GPHY IP completely by means of the MDIO interface, according to IEEE 802.3-2008.

### 3.5.2.7 Power Management

This section introduces the power management functions of the GPHY IP.

#### 3.5.2.7.1 Power Down Modes

This section introduces the power-down modes supported by the GPHY IP. [Figure 20](#) depicts how these modes are associated to states. The functionality of each mode and the state transitions are discussed in detail in the subsequent sections.

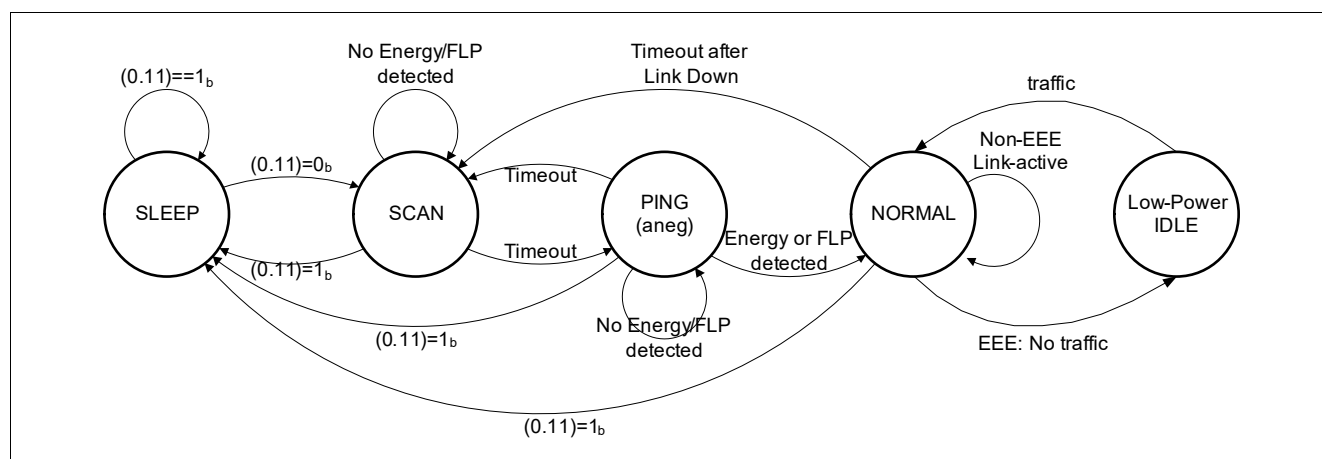

**Figure 20 State Diagram for Power-Down Mode Management**

#### 3.5.2.7.2 Sleep Mode

The SLEEP mode is entered by setting register (0.11) to logic one, regardless of the current state of the device. Active links are dropped when the PHY is leaving the NORMAL mode. The sleep mode corresponds to power down as specified in IEEE802.3, clause 22.2.4.1.5. The device still reacts to MDIO management transactions. The interface clocks to the MAC are switched off. No signal is transmitted on the MDI.

Since this mode is entered manually, the device neither wakes itself nor any link partner. This functionality can be enabled by setting register (0.11) to logic zero and thus entering the SCAN mode.

#### 3.5.2.7.3 Scan Mode

The SCAN mode differs from the SLEEP mode in that the receiver periodically scans for signal energy or FLP bursts on the media. In this mode, there is no transmission. This must correspond to the state of “NO-LINK”.

After a certain time-out has expired, the PHY moves into the PING mode. The time-out is randomized between configurable limits to prevent deadlock conditions.

#### 3.5.2.7.4 Ping Mode

The PING mode is similar to the SCAN mode except that the transceiver transmits an FLP burst onto the TPI for a programmable amount of time. This is used to wake potential link partners from the power-down state. This must correspond to the state of ANEG.

After a certain time-out has expired, the PHY moves back into SCAN mode. The time-out is randomized between configurable limits to prevent deadlock conditions.

### 3.5.2.7.5 Normal Mode

The NORMAL mode is used to establish and maintain a link connection. Once this connection is dropped, the PHY moves back into SCAN mode after a configurable time-out has expired.

### 3.5.2.7.6 Low-Power Idle Mode: Energy-Efficient Ethernet

The IEEE 802.3az supports Energy-Efficient Ethernet (EEE) operation. The standard is also supported by the GPHY IP. Since the method used for saving energy depends on the PHY speed, this section is divided into 3 subsections corresponding to the various speeds of 10BASE-Te, 100BASE-TX and 1000BASE-T. Except for 10BASE-Te, the general idea of EEE is to save power during periods of low link utilization. Instead of sending an active idle, the transmitters are switched off for a short period of time (20 ms). The link is kept active by means of a frequent refresh cycle initiated by the PHY itself during low power mode. This sequence is repeated until a wake request is generated by one of the link-partners MACs. An EEE-compliant MAC must grant the PHY a time budget of wake time before the first packet is transmitted. The basic principle is shown in [Figure 21](#).

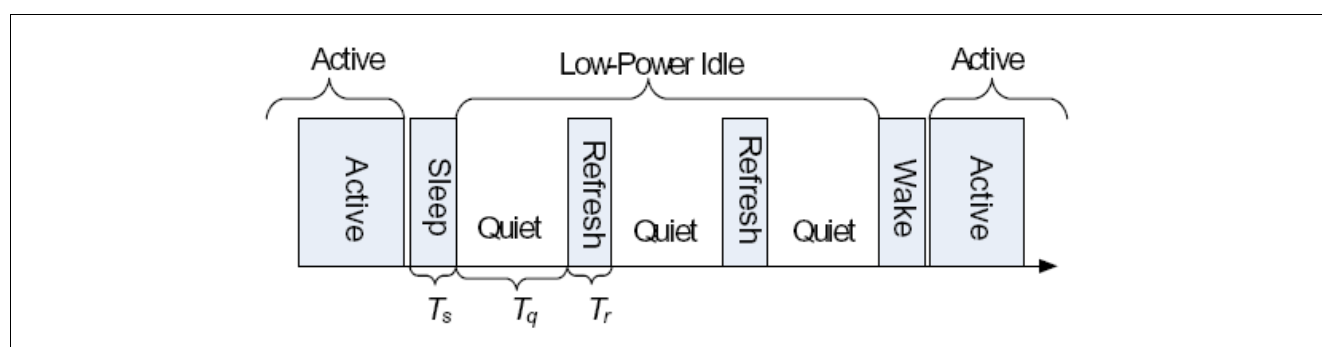

Figure 21 EEE Low-Power Idle Sequence

#### Auto-Negotiation for EEE Modes

It is imperative that the EEE capability is advertised, since, except for 10BASE-Te, a compliant link partner is required. Similarly to 1000BASE-T auto-negotiation, the GPHY IP automatically advertises EEE capability when this is enabled using next pages. EEE capability is stored in the `MMD.ANEG.EEE_AN_ADV` registers. Setting this register to zero disables EEE. After a successful negotiation the link partners' capabilities are stored in the `MMD.ANEG.EEE_AN_LPADV` register. After a successful auto-negotiation, the GPHY IP performs an auto-resolution on the exchanged capabilities. The result is combined with the speed resolution. Whether or not a link is able to operate EEE is reported in the `MDIO.PHY.MIISTAT.EEE` register.

## 3.6 Reduced Media-Independent Interface

### 3.6.1 Features

The Reduced Media-Independent Interface (RMII) implements a MAC interface with a reduced pin count, but only supporting speed of 100 Mbit/s. If the MAC interface is configured in RMII mode, then the Gigabit Ethernet Switch does not negotiate 1000 Mbit/s functionality and therefore behaves like a fast Ethernet PHY. The RMII is fully compliant with the specification of the RMII Consortium [2].

### 3.6.2 Functional Description

When the RMII interface must be used, connect pins to the SoC as described in [Table 5](#).

### 3.6.3 RMII Configuration

#### REFCLK Master

Perform these steps for REFCLK Master:

1. Switch Top Level PDI Register 0xF100 (MII\_CFG\_5)
2. Configure from 0x2044 to 0x40B3, with:
  - a) RMII clock is set as output
  - b) The clock rate is at 50 MHz
  - c) RMII mode
3. Switch Top Level PDI Register 0xF410 (PHY\_ADDR\_5)
4. Configure from 0x1805 to 0x2a05

#### REFCLK Slave

Perform these steps for REFCLK Slave:

1. Switch Top Level PDI Register 0xF100 (MII\_CFG\_5)
2. Configure from 0x2044 to 0x4033, with:
  - a) RMII clock is set as input
  - b) The clock rate is at 50 MHz
  - c) RMII mode
3. Switch Top Level PDI Register 0xF410 (PHY\_ADDR\_5)
4. Configure from 0x1805 to 0x2a05
5. The 50 MHz clock must be sourced from the SoC, crystal, or oscillator externally

## 3.7 SGMII Interface Function Description

### 3.7.1 Features

- One SGMII SerDes
  - Cisco\* Serial-GMII Specification Rev 1.8 standard compliant operation at 1.25 Gbaud/s; extensions to achieve 3.125 GBaud/s by overclocking the SerDes
  - 2.5 Gbps (one lane of XAUI conforming per 802.3, part 4, clause 47: 10 Gigabit Attachment Unit Interface (XAUI)) full duplex
  - SerDes interface includes Clock and Data Recovery (CDR)
  - Supports multiple power-down modes
  - Supports programmable TX attenuation and amplification
  - Supports programmable flat-band RX equalization
  - Supports auto-calibration of RX and TX impedances
  - Supports test loop feature for debugging
  - Requires an external resistor to calibrate the termination impedance of the high speed RX and TX signals
- One SGMII PCS
  - Integrates IEEE 802.3 clause 36 and 37 compliant PCS component
  - Cisco\* Serial-GMII Specification Rev 1.8 standard compliant operation at 1.25 Gbaud/s; extensions to achieve 3.125 GBaud/s by overclocking the SGMII PCS
  - 2.5 Gbps (one lane of XAUI conforming per 802.3, part 4, clause 47: 10 Gigabit Attachment Unit Interface (XAUI)) full duplex
  - 2.5 Gbps full duplex, 1 Gbps full duplex, 100 Mbps full/half duplex, and 10 Mbps full/half duplex are supported
  - Support connecting to an external MAC at 1 Gbps full duplex or 2.5 Gbps full duplex
  - Support connecting to an external 1000BASE-T Ethernet PHY
  - Support connecting to an external 1000BASE-X (Fiber or Copper) Ethernet PHY
  - Support operation mode with auto-negotiation and without auto-negotiation
  - EEE LPI Encoding is not supported

### 3.7.2 Functional Description

#### 3.7.2.1 Typical Applications

This section introduces and suggests typical applications of the GSW125 with SGMII interface.

##### 3.7.2.1.1 Interface to an External MAC

It is GMII-replacement mode. It serves to primarily reduce the pin count of the interfaces between two MACs by replacing the signals with a 4-wire (2 pairs) differential connection. In this mode, auto-negotiation is disabled. The baud rate (1.25 Gbaud/s or 3.125 Gbaud/s), the bit rate (1 Gbps or 2.5 Gbps), pause support capability are preconfigured and must be known and same to both sides of the SGMII interface in advance. The link status is always on and in full duplex mode.

##### 3.7.2.1.2 Interface to an External 1000BASE-T Ethernet PHY

Known as the SGMII mode, this mode follows the Cisco\* Serial-GMII Specification 1.8. It serves to primarily reduce the pin count of the interface between a switch and PHY by replacing the signals with a 4-wire (2 pair) differential connection. Instead of transmitting the capability advertisement information as defined in IEEE 802.3 Clause 37,

in this mode, the PHY sends over the control register value, and the MAC side macro acknowledges this. With this done, normal data transmission can commence. It is to be noted that the baud rate of the line is not negotiated (always 1.25 Gbaud/s), this is pre-fixed and known to both sides in advance. But the bit rate (10/100/1000 Mbps), duplex mode, link status and pause capability can be changed via auto-negotiation.

### 3.7.2.1.3 Interface to an External 1000BASE-X Ethernet PHY

In this scenario, the MAC-connected SGMII IP is connected to an optical SFP transceiver over a 1000BASE-X link. The optical PHY is assumed to be merely translating the electrical signals to optical and transmitting them over an optical fibre. In this application, the SGMII PCS in GSW125 works according to the clauses 36 and 37 in the IEEE 802.3 standard, conducting full-blown auto-negotiation for the link. It acts as a PCS for the optical PHY, with all capabilities as required by the standard. External 1000BASE-T Copper Ethernet PHY with an 1000BASE-X interface can also be connected to GSW125 in this manner.

### 3.7.2.2 Modes of Operation

The two basic operating modes are the SGMII mode and 1000BASE-X mode. In the former, it acts as GMII replacement, and does a minimum of link configuration operations before data transfer can commence. In the 1000BASE-X mode, full-fledged auto-negotiation including next page operation is supported.

In addition, [Table 25](#) lists the macro that can be operated in various different bit rates.

**Table 25 Bit Rates**

| Application  | PCS Mode   | Auto-Negotiation Mode | Baud Rate at Line | Bit Rate Duplex           | Data Repeat | Link Info  |
|--|------------|-----------------------|-------------------|---------------------------|-------------|--|
| <a href="#">Interface to an External MAC</a>                     | Don't Care | Disable               | 1.25 Gbaud/s      | 1 Gbps Full Duplex        | 1           | Link info (bit rate and pause capability, link status) are known and preconfigured at both side. |
|  |            |                       | 3.125 Gbaud/s     | 2.5 Gbps Full Duplex      | 1           |  |
| <a href="#">Interface to an External 1000BASE-T Ethernet PHY</a> | SGMII      | Enable                | 1.25 Gbaud/s      | 10 Mbps Full/half Duplex  | 100         | Link info (bit rate, duplex mode, pause capability and link status) are auto-negotiated.         |
|  |            |                       |                   | 100 Mbps Full/half Duplex | 10          |  |
|  |            |                       |                   | 1 Gbps Full Duplex        | 1           |  |
| <a href="#">Interface to an External 1000BASE-X Ethernet PHY</a> | 1000BASE-X | Enable                | 1.25 Gbaud/s      | 1 Gbps Full Duplex        | 1           | Link info (pause capability and link status) are auto-negotiated.                                |

For SGMII mode, for bit rates of 1 Gbps or less, each data symbol is repeated 10 or 100 times as required by the SGMII specification, to arrive at the baud rate of 1.25 Gbps. The 8b10b coding scheme ensures that there are enough transitions for the clock recovery mechanism in the PMD to operate smoothly. To achieve this the bit rate is increased the bit rate by 25%.

### 3.7.2.3 Test Features, Status and Enabling

The GSW125 has several loops to aid system debugging, as shown in [Figure 22](#).

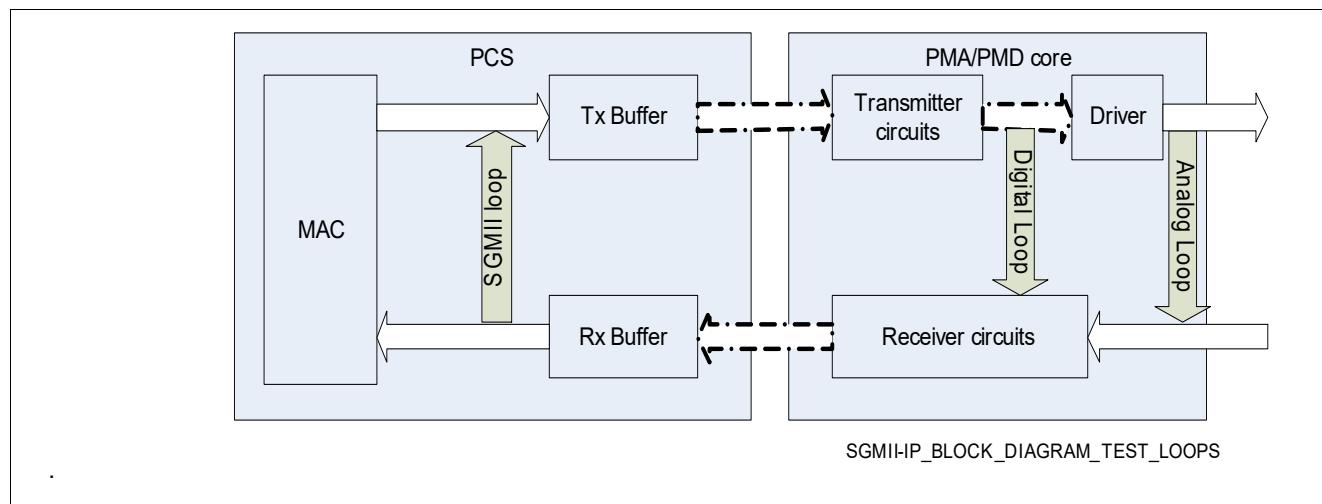

**Figure 22** Test Loops in the GSW125

#### 3.7.2.3.1 PMA/PMD Loops

The PMA/PMD core provides two loops internal to itself, both of which loops the data from the transmit path to receive path, as shown in [Figure 22](#),

1. Digital Loop: Digital serial data loopback from transmit to receive. It takes data from the transmit path just before the analog drivers, and inserts into the receive path just after the first stage.
2. Analog Loop: Analog signals are looped back from transmit to receive path. Here the entire circuits of both the transmit and receive paths are activated. However, this test cannot be done on packaged devices due to loading effect of parasitic capacitances. This is meant for wafer level testing only.

The above loops are activated by register bits.

#### 3.7.2.3.2 PCS Loops

In addition to above test mode, the logic external to the PMA/PMD core provides a loop as shown in [Figure 22](#) called SGMII Loop. This loops data from receive buffer output to transmit buffer input. This is activated by LPB bit in the SGMII\_PCS\_CFG register. This loop enables returning of data coming in from the analog interface back to itself.

### 3.8 Switch Fabric Functional Description

#### 3.8.1 Overview

The Gigabit Ethernet Switch Macro is responsible for classifying, storing and forwarding multiple data flows. The macro consists of storage buffer, packet queueing and packet classification units. Ingress data can be received on one of the port interfaces, classified and placed in the appropriate QoS queue in the Shared Buffer. Ingress policing and access control rules are applied to the received traffic and packets not compliant to the rules are discarded. Prior to packet being fetched from the shared memory and transmitted on one of the egress ports, it is subject to egress scheduling and rate shaping.

Figure 23 describes a typical packet data flow through various stages of switch.

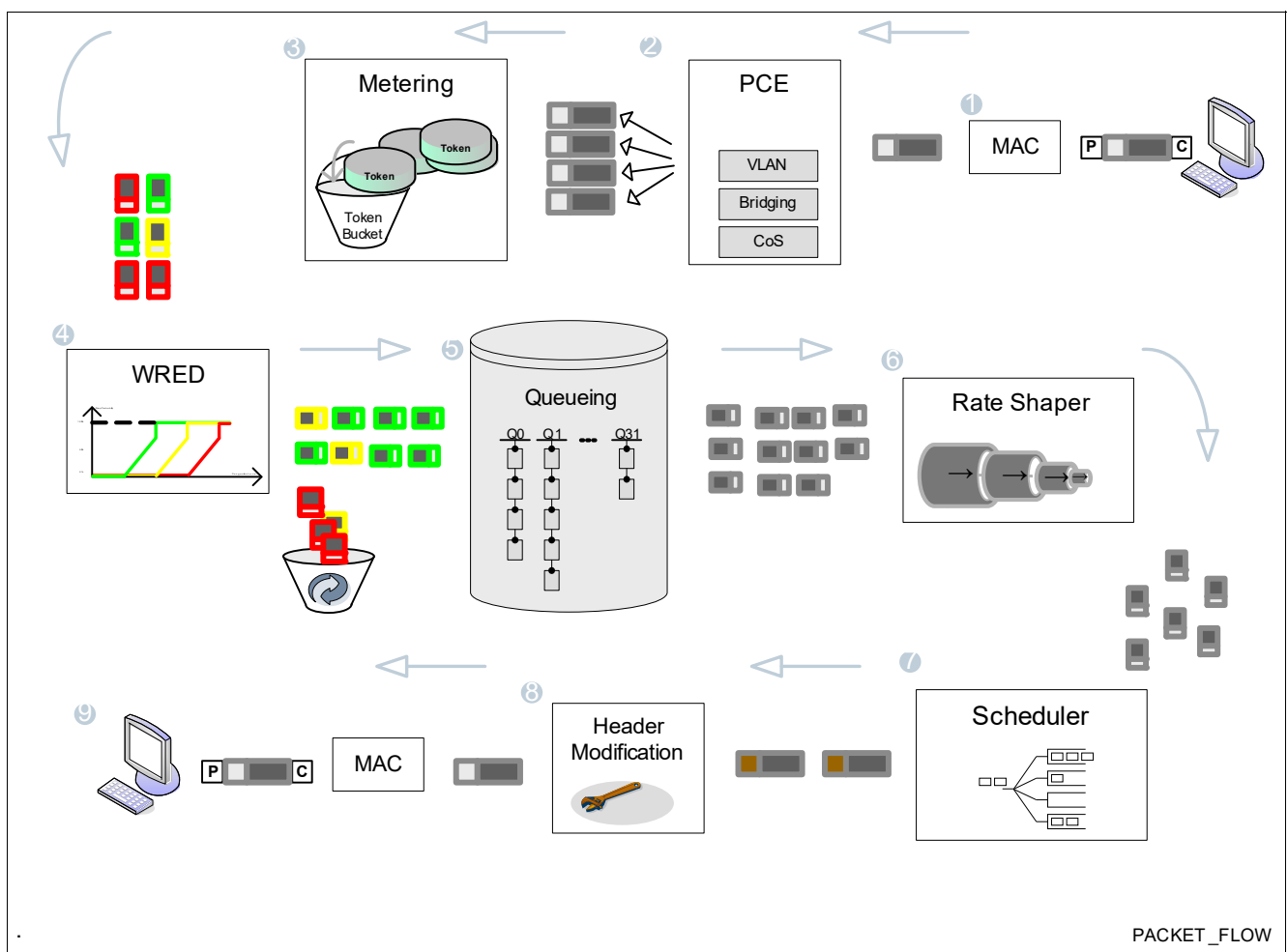

Figure 23 Packet Flow Diagram

Packet received on the ingress port is stripped from the Ethernet Preamble and checked for correct FCS. In case of any reception errors the packet might be discarded. Received packet is classified in the Packet Classification Engine and assigned to an appropriate QoS queue. Prior to accepting the packet to certain queue it is subject to metering and WRED functions. Packets marked as non-conforming by the Metering Engine might be discarded by the WRED algorithm based on the configurable drop precedence. Prior to transmission on the egress side, the packet is subject to Rate Shaping. When transmission of the packet is not delayed by the Rate Shaper it is subject to the Scheduling algorithm (WFQ or SP). Packets scheduled for transmission are subject to Header Modification, such as, VLAN Tag modification or DSCP remarking.



## 3.8.2 Ethernet Bridging

Ethernet bridging (or Switching) is the primary task of the Gigabit Ethernet Switch Macro. The frames received on one of the ingress ports must be forwarded to the appropriate destination port. The destination port is determined by a lookup in the MAC bridging table. The MAC bridging table can be populated by software (static entries) or entries can automatically be learned by the hardware learning function. The entries learned by the hardware can age out after a configurable time and are deleted from the MAC bridging table.

### 3.8.2.1 Parsing

The Gigabit Ethernet Switch Macro features a Parser realized as a microcoded engine. This allows a flexible adaptation to any future protocol changes. The parser microcode evaluates the frame header and is capable of extracting all relevant information up to the layer 4 protocol from the frame. The microcode must be loaded otherwise only the MAC destination and MAC source address is extracted from the frame. The parsed fields are:

- MAC source and destination address (also available without loading the parser microcode)
- Special tag
- Ethernet type field
- Service VLAN tag (VLAN ID, DEI/CFI and PCP)
- Customer VLAN Tag (VLAN ID, CFI and PCP)
- PPPoE Session ID (for PPPoE frames)
- DSCP/TOS/Traffic Class (for IPv4/IPv6 packets)
- IP Protocol/Next Header (for IPv4/IPv6 packets)
- IPv4/IPv6 source and destination address (for IPv4/IPv6 packets)
- Application, typically L4 source and destination port (for UDP and TCP)
- Flags (IP version, WOL Packet Flag, Parser Error Flag, Length Encapsulated Packet Flag, IP Short Option Flag, IP Long Option Flag)

A packet is also parsed when it was received encapsulated in a PPPoE frame. The parsing considers Zero or One Service tag, any number of customer VLAN tags and any number of extension headers, the parsing continues as long as the parsing depth (256 bytes) is not exceeded. When the Ethernet type field is not IPv4, IPv6 or PPPoE and IP protocol/next header is not UDP or TCP, the parsing is finished and the next four bytes are stored as application field. This allows to set up rules for unknown protocols.

*Note: The outer customer VLAN tag is extracted by locking the register after the first customer VLAN tag is detected, the following customer VLAN tags cannot overwrite the value.*

*Parsing is not continued for length encapsulated frames.*

### 3.8.2.2 MAC Bridging Table

The MAC bridging table is realized as a hash table with four collision buckets and holds the lookup key (MAC address, FID), control information (static indication, aging timer, changed indication) and the result (port or port map, MAC VLAN ID). A port map is a bitmap where each bit represents a single port. The port map allows to send the frame to multiple destination ports and is available for static entries only.

The Gigabit Ethernet Switch Macro supports shared and independent VLAN learning (SVL or IVL). It is achieved by mapping the default customer VLAN ID or a flow to a forwarding identifier (FID) used as part of the lookup key, together with the MAC address, for the MAC bridging table lookup. By default, FID is zero and all entries belong to shared VLAN learning. See [Shared/Independent VLAN Learning](#) for details on VLAN learning modes.

The Gigabit Ethernet Switch Macro supports MAC based VLAN. For example, it offers the possibility to extend the number of interfaces behind the same physical Ethernet port. The MAC VLAN ID represents a single sub-interface or a group of sub-interfaces behind a port. This is achieved by learning the MAC VLAN ID (shortened as MVID in this document) together with port ID. The MAC VLAN ID is carried via the Service VLAN Tag.

Entries are entered automatically by hardware (dynamic MAC address learning, described in [Dynamic Source MAC Address Learning and Aging](#)) or entered by software via manual learning. The software writes static entries into the MAC bridge table but it is also possible to write dynamic entries which are subject to aging.

The MAC bridge table is able to hold unicast, multicast or broadcast addresses. The table entries containing multiple egress ports as a destination, are entered only as static entries, by appropriate management action.

The MAC table is accessed by software to read out static or dynamically learned entries and optionally modify them. The following access modes are supported. For each access, a 12-bit MAC table pointer is returned.

- By KEY: MAC address and FID.
- By a 12-bit MAC table pointer
- By reading next valid entry
- By reading next changed entry. The changed entry is the entry added, updated or removed (invalidated) after the last read.

*Note: Due to the table 4-bucket hash architecture, some MAC addresses may be rejected while others may still be added.*

|               |     |          |          |          |                |         |
|---------------|-----|----------|----------|----------|----------------|---------|
| Dynamic Entry |     |          |          |          |                |         |
| MAC address   | FID | static=0 | Port ID  | age time | "Changed" Flag | VLAN ID |
| Static Entry  |     |          |          |          |                |         |
| MAC address   | FID | static=1 | port map |          | VLAN ID        |         |

**Figure 24 MAC Bridge Table Entry Formats**

### Bridging Table Flushing

When all learned entries must be removed, the complete MAC bridging table can be cleared by hardware automatically, with the help of an automated flushing function. This function removes all entries, static as well as dynamic ones. The flush function is triggered by writing 1<sub>B</sub> to MTFL bit in PCE\_PCTRL\_0.

### 3.8.2.3 MAC Based Forwarding

For each frame the MAC destination address and the FID form, a lookup key is used to determine the destination port (or port map) and MAC VLAN ID. The lookup key is hashed and the hash index is used to address the MAC bridging table and read out the contents of the four buckets. The result of the lookup is an egress port (or multiple ports in case of a multicast entry) and MAC VLAN ID. In case the egress port or port map is programmed to all-zero, the frame is discarded.

### Default Forwarding

When no match for the destination MAC address + FID pair is found in the Bridging table, the default port map is used. A default port map is configured for L2 unicast (via PCE\_PMAP\_3) and L2 multicast/broadcast (via PCE\_PMAP\_2) addresses separately. After reset, unknown destinations are flooded to all egress ports. MAC VLAN ID is "NULL" (all 0) for unknown unicast, unknown multicast and broadcast.

### 3.8.2.4 Dynamic Source MAC Address Learning and Aging

The MAC bridging table is populated automatically when learning is enabled on the ingress port. The lookup key (concatenation of the source MAC address and the FID) is hashed and the index is used to address the MAC bridging table.

Dynamic learning operates in the following way:

- **Match Found:** When the entry is found and the PortID+MVID association with SA+FID is unchanged, the entry aging timer is refreshed. When the entry contains a different port number or different MVID, the old PortID + MVID in the entry is replaced by the new PortID+MVID.

*Note: Static entries are not modified by dynamic learning function. When the matched entry is static, the association is not changed.*

- **No Match - Table not full:** When the SA+FID pair is not found in any of the collision buckets and an empty bucket exists for this hash index, the lookup key is stored together with the PortID+MVID pair and the aging timer is refreshed.
- **No Match - Table full:** When the SA+FID pair is not found and there are no available entries (i.e. all collision buckets are full) and LRU mode (Least Recently Used) of the switch is enabled, the oldest entry (lowest age time) is replaced by the new lookup key and new PortID+MVID pair. When the LRU mode is disabled, no entry is overwritten and the source MAC address is not learned.
- **No Match - All static:** When the SA+FID pair is not found and all the collision buckets for this hash index are occupied by static entries, no entry is overwritten and the source MAC address is not learned.

The dynamic learning of SA+FID pair is performed only when all of the following conditions are fulfilled.

- The source MAC address is a unicast address.
- Learning is enabled on the ingress port.
- The frame discarded by the filtering function is not due to ingress reasons (e.g., VLAN filtering, Flow Classification filtering).
  - See [Flow Classification Function](#) for details.
- The bridging table is not full or table is full but overwriting existing entry is allowed.
- The number of entries for the port does not exceed the learning limit when MAC learning limitation is enabled. See [MAC Learning Limitation](#) for more details.
- The ingress PortID+MVID is identical to the stored PortID+MVID pair in the MAC bridge table when stored port MAC port locking is not enabled and the receiving port MAC spoofing is not disabled. See [MAC Port Locking and MAC Port Spoofing Detection](#) for more details.

When a packet SA+FID pair is new or its association with the PortID+MVID pair is changed, the packet can be mirrored to the monitoring port. This feature is switched on or off (default) via configuration (VIO\_9 bit in PCE\_PCTRL\_3) per ingress port.

### MAC Address Aging

To avoid table overflow over time, the entries learned must be removed once they have not been used for a certain amount of time. This functionality is covered by the aging process, which removes bridging table entries after a configurable time of inactivity (age time). The range of the age time reaches from 1 s up to more than 24 hours. A typical value of 300 s is used by default. Static entries do not age out, they must be deleted by software. The aging is enabled or disabled per ingress port. When disabled, addresses learned from this port are not aged out.

### Shared/Independent VLAN Learning

When the VLAN function is used, each VLAN group is mapped to the Filtering Identifier (FID). Single or multiple VLAN groups are assigned to the same or to different FIDs. VLANs assigned to the same FID perform SVL. VLANs assigned to different FIDs perform IVL. The source MAC address of the received frame is learned using either the IVL or SVL method. Shared and independent VLAN learning is defined as follows:

- **Independent VLAN Learning**  
Each VLAN uses its own filtering database. The source MAC address learning is performed as a result of incoming VLAN traffic and is not made available to any other VLAN for forwarding purposes. One FID is assigned per VLAN group.
- **Shared VLAN Learning**  
Two or more VLANs are grouped to share common source MAC address information. This setting is useful for configuring complex VLAN traffic patterns without forcing the switch to flood the unicast traffic in each direction. Addressing information is shared among VLANs. One FID is used by two or more VLAN groups.

By default, all VLAN groups are assigned to the same FID (FID=0) and Shared VLAN Learning is performed for the source MAC addresses.

### 3.8.2.5 Layer 2 Security

This section summarizes the L2 security features of the GSWIP. The L2 security features comprise:

- IEEE 802.1X
- MAC Learning Limitation, allows only a limited number of MAC addresses to be learned on a port.
- MAC Port Locking and MAC Spoofing Detection, allows only frames with a previously learned MAC and PortID association.
- MAC Table Freeze, allows only frames with previously learned MAC addresses.
- Source MAC Address Filtering and Destination MAC Address Filtering, filters user defined MAC addresses.

#### IEEE 802.1X (Port-based Authorization) Support

Gigabit Ethernet Switch Macro supports the port states required for the 802.1X - Port Based Authorization and Network Access Control Protocol functionality. The following states are supported per port:

- Not Authorized. In this state, all frames received on the port are dropped, the source MAC address is not learned. Not authorized port is not taken as a destination for any frame received on another port.
  - EAPOL frames can ignore the port state and be received and forwarded to the original destination.
- Authorized for Ingress Traffic only. In this state, all regular traffic received on the port is accepted. However, the port is not allowed to transmit any traffic. This port is not taken as a destination for any frame received on another port.
  - EAPOL frames can ignore the port state and be received and forwarded to the original destination.
- Authorized for Egress Traffic only. In this state, all regular traffic received on the port is discarded. The port is allowed only to transmit traffic. This port can be taken as a destination for any frame received on another port.
  - EAPOL frames can ignore the port state and be received and forwarded to the original destination.
- Authorized. Normal operation, ingress and egress traffic on this port is enabled for all frames.

When both protocols, STP and IEEE 802.1X, are enabled - port states for the 802.1X are effective only when STP port state is set to Forwarding.

#### EAPOL frames forwarding

The Gigabit Ethernet Switch Macro supports special forwarding rules for the Extensible Authentication Protocol over LAN (EAPOL) frames used by the 802.1X protocol to exchange authentication information. EAPOL frames are identified by the unique group destination MAC address 01:80:C2:00:00:03<sub>H</sub>, and the Ethernet Type 88 8E<sub>H</sub>.

When the 802.1X functionality is enabled, the EAPOL frame forwarding is added as a dedicated rule to the Traffic Flow Table with a special action to ignore (cross) any states configured for the ingress or egress ports. The EAPOL frames must be forwarded to the defined CPU port or any other port where managing entity is connected for further 802.1X processing.

#### MAC Learning Disable

The MAC learning is disabled (via LNDIS bit in PCE\_PCTRL\_3) per ingress port. When MAC learning is disabled, the source MAC address is not learned and MAC learning limitation is not checked.

#### MAC Learning Limitation

The number of MAC addresses allowed to be learned are limited per port. This feature provides protection from DoS attacks and avoids bridging table overflow by single ports sending too many frames with different source MAC addresses.

By default, the number of MAC addresses learned by the switch is only limited by the size of the internal MAC bridging table. When MAC learning limitation is enabled on the ingress port and the programmed limit is reached, no more addresses are learned for this specific port. Dynamic learning is still enabled on other ports. The learning limitation violation is indicated to the software and the violating frame is configured to be discarded or forwarded as a normal frame. Regardless of the forwarding action, the source MAC address of the violating frame is not learned. Refreshing of already stored addresses is allowed and not considered a violation.

The learning limitation configuration may be changed (increased or decreased) during run-time. When number of addresses that can be learned on the port increased from the previous limit, more addresses from that port may now be added to the table. When the number of addresses that can be learned on the port decreased, no new addresses are learned and no active flushing is performed to reach the learning limitation. Addresses are expected to be aged out.

*Note: The setting learning limitation to zero disables the dynamic learning on that port, the source MAC address is looked up and violating frame can be configured to be discarded or forwarded.*

**Table 26** describes the MAC learning disable, MAC learning limitation and corresponding behavior.

**Table 26 MAC Learning Disable and MAC Learning Limitation Description**

| LNDIS in PCE_PCTRL_3 (per ingress port) | LRNLIM in PCE_PCTRL_1 (per ingress port) | PLIMMOD in PCE_GCTRL_0 (global) | Description   |
|---|--|---------------------------------|---|
| 1 <sub>B</sub>                          | Don't care                               | Don't care                      | Source MAC address is not learned, the packets are not dropped  |
| 0 <sub>B</sub>                          | != 255                                   | 0 <sub>B</sub>                  | Source MAC address is not learned and packets are dropped when learning limitation is exceeded. Source MAC address is learned and packets are not dropped when learning limitation is not exceeded.     |
| 0 <sub>B</sub>                          | != 255                                   | 1 <sub>B</sub>                  | Source MAC address is not learned and packets are not dropped when learning limitation is exceeded. Source MAC address is learned and packets are not dropped when learning limitation is not exceeded. |
| 0 <sub>B</sub>                          | 255                                      | Don't care                      | Source MAC address is learned and packets are not dropped.  |

### MAC Port Locking and MAC Port Spoofing Detection

The port locking and spoofing detection function are intended to prohibit MAC spoofing attacks.

Ingress traffic from a port carrying a source MAC address that has previously been learned on a different port (port locking enabled on the stored port) is considered a violation. When a port locking violation is detected, this can be indicated to the software and the violating frame can be configured to be discarded. Regardless of the forwarding action, source MAC address of the violating frame is not learned.

Ingress traffic from the port on which port spoofing detection is enabled (via SPFDIS bit in PCE\_PCTRL\_0) carrying a source MAC address that has previously been learned on a different port (regardless of its port locking setting) is considered a violation. When port spoofing is detected, this can be indicated to the software and the violating frame can be configured to be discarded (via SPFMOD bit in PCE\_GCTRL\_1). Regardless of the forwarding action, source MAC address of the violating frame is not learned. MAC Port Spoofing detection function allows moving a MAC addresses to the port on which spoofing detection is disabled.

This feature ensures that a malicious user cannot spoof another user MAC address and gain illegitimate access to data traffic that he does not own.

When a user must change from one port to another, a wait time up to the configured aging time is required to be able to re-connect. When the locked MAC address is a static entry or when the aging time is too long, moving users between ports on which spoofing detection are enabled or port locking are enabled requires management interaction.

### MAC Table Freeze

MAC Table Freeze can be enabled globally to freeze the MAC address table. When enabled no new entries can be entered into the MAC address table even when learning is enabled on the port. Refreshing of existing entries is performed, also when learning is disabled (by setting learning limitation to zero). This feature allows to learn the MAC addresses from the connected stations for a given time and then freeze the MAC address table. Afterwards no new MAC addresses are learned. When learning is enabled and port locking is disabled, known stations are allowed to move. When port locking is enabled or learning is disabled, station moves are not allowed. When a freeze violation is detected it can be configured to either discard the frame or to forward the frame. When the frame is to be discarded it can be configured to send it to the monitoring port. The freeze violation can be indicated to the software via a maskable interrupt.

### Source MAC Address Filtering

A static MAC Table entry for specific source MAC address + FID pair can be programmed with a NULL (all-zero) value for the associated port map. When the source MAC address + FID pair of the received frame matches the configured entry, the frame is discarded. This function can be enabled or disabled per port.

Dedicated violation indication is asserted for any frame that has been discarded.

### 3.8.2.6 Spanning Tree Protocol Support

Gigabit Ethernet Switch Macro supports the port states required for the Spanning Tree Protocol (STP) functionality. 16 spanning tree instances per port are supported. Each Spanning Tree instance is associated with least significant 4 bits of the Filtering Identifier (FID) and a port. The port state programmed for one FID does not have effect on the behavior of another FID of the same port. The following states are supported per STP instance:

- **Disabled:** When disabled, all ingress frames are dropped, the source MAC address is not learned. All egress frames are discarded.
- **Blocking/Listening:** In this state, all ingress and egress regular traffic is discarded. BPDU frames can ignore the port state and be forwarded to the STP managing entity. Source MAC address is not learned in this state.  
*Note: To be recognized by the switch, BPDU frames must be defined in the appropriate rule in Traffic Flow table.*
- **Learning:** In this state, all ingress and egress regular traffic is discarded. Source MAC address is learned in this state. BPDU frames can ignore the port state and be forwarded to the STP managing entity.  
*Note: To be recognized by the switch, BPDU frames must be defined in the appropriate rule in Traffic Flow table.*
- **Forwarding:** Normal operation, ingress and egress traffic is enabled for all frames.

### BPDU frames forwarding

Gigabit Ethernet Switch Macro supports special forwarding rules for the Bridge Protocol Data Unit (BPDU) frames used by the STP protocol to exchange information about bridge IDs and root path costs. BPDU frames identified by the unique group destination MAC address 01:80:C2:00:00:00<sub>H</sub>.

When STP functionality is enabled, BPDU frame forwarding is added as a dedicated rule to the Traffic Flow Table with a special action to ignore (cross) any states configured for the ingress or egress ports. BPDU frames must be forwarded to the defined CPU port or any other port where managing entity is connected for further STP processing.

### 3.8.2.7 Reserved MAC Addresses

The IEEE standard defines group destination MAC addresses in the range from 01:80:C2:00:00:00<sub>H</sub> to 01:80:C2:00:00:FF<sub>H</sub> as reserved. The Gigabit Ethernet Switch Macro can be configured to disable the forwarding of the frames containing reserved addresses. In this case a dedicated rule is added to the Traffic Flow Table with an action to discard any frame within the reserved address range.

### 3.8.2.8 Flow Control Function

To prevent buffer congestion and packet drop the Gigabit Ethernet Switch Macro supports a flow control mechanism. In full duplex operation the sender is notified to start or stop the transmission via a PAUSE frame based on the IEEE 802.3x standard. The Gigabit Ethernet Switch Macro is able to transmit/receive and react accordingly to 802.3x flow control frames. In half duplex operation, the Gigabit Ethernet Switch Macro supports a back pressure mechanism, specifically, a jam pattern is transmitted on the port forcing a collision. Flow control can be enabled or disabled per port. When enabled, it depends on the auto-negotiation result of the attached PHY.

Flow control is applied in the following ways.

When flow control on a port is activated by any one of the following triggerings, flow control is activated on that port.

When flow control on a port is deactivated by all the following triggerings, flow control is deactivated on that port.

- **Global flow control:** Flow control is activated when the global buffer congestion level exceeds a programmable global threshold and is deactivated when the global buffer congestion level is below a programmable global threshold. The flow control applies to all enabled ports.
- **Ingress port congestion based flow control:** Flow control is activated when the ingress port local buffer congestion level exceeds a programmable local threshold (via SDMA\_PFCTHR9) and deactivated when the local buffer congestion level drops below a programmable local threshold (via SDMA\_PFCTHR8). The flow control applies to each port individually.
- **Ingress port metering based flow control:** When the global buffer filling level exceeds a programmable global threshold (via SDMA\_FCTHR2), flow control is activated on the port that exceed the configured ingress rate. When the global buffer filling level drops below a programmable threshold (via SDMA\_FCTHR1) or the traffic rate is reduced below the configured rate, flow control is deactivated on the port. See [Rate Metering](#) for details regarding the metering based flow control and metering assignment.

### 3.8.2.9 Port Trunking Functions

Switch supports link aggregation according to IEEE 802.3ad. Link aggregation, also called port trunking, allows to combine multiple ports to a trunk for high bandwidth inter-switch links. A maximum of two ports form a trunk, there is no restriction on the port sequence used for the trunk (port 0 and port 1 may form a trunk but also port 0 and port 5 may form a trunk). The ports must have the same speed and must work in full duplex mode only, otherwise a proper trunking functionality cannot be achieved. Fault tolerance is not supported. When one link is broken or disabled for any reason (link on/off), packets are lost.

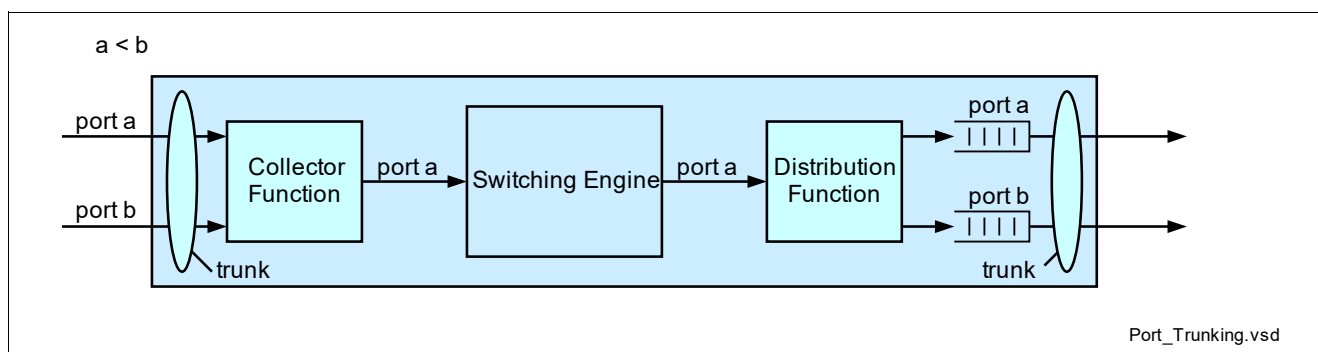

**Figure 25 Port Trunking Function**

When a frame was received on a trunk, the lowest port number of the trunk is used as ingress port by the collector function. This ingress port alone is used for the further processing, including learning and port security. The other port number (=higher port number of the trunk) is not used, all port parameters are taken from the lowest port number.

When a frame is to be transmitted on a trunk, the lowest port number of the trunk is the default port. Since the trunk consists of two ports it must be determined which of the ports is used for the transmission. This is done by a distribution function which evenly distributes the frames on the two ports of the trunk.

The distribution is according to either a hash function of 32-bit key (XOR of all bits) or a Flow classification action. The hash key consists of the following fields.

- MAC Destination Address (MAC\_DA): 8 bit only (MAC\_DA[7:0]), can be masked via DA bit in PCE\_TRUNK\_CONF
- MAC Source Address (MAC\_SA): 8 bit only (MAC\_SA[7:0]), can be masked via SA bit in PCE\_TRUNK\_CONF
- IP Destination Address (IP\_DA): 8 bit only, (IP\_DA[7:0]), can be masked via DIP bit in PCE\_TRUNK\_CONF
- IP Source Address (IP\_SA): 8 bit only, (IP\_SA[7:0]), can be masked via SIP bit in PCE\_TRUNK\_CONF

When a field is masked, all zero value is assumed for that field for hash calculation. When a packet is not an IP packet, all zero value is assumed for IP address.

The higher port number of a trunk must not be configured as destination port or in a destination port map.

When a link in a trunk goes down, the link is no longer used in the distribution function and the partner link gets all the frames. The egress queue of the disabled port is flushed.

When a link changes the speed we treat the port which has the lower speed same as link down.

The RMON counters must be triggered for each ingress and egress port separately.

Flow control is also separately triggered for each ingress port. Each egress port can be shaped individually. The combined rate shaping of the trunk is also supported.

### 3.8.2.10 Gigabit Media Access Control (GMAC) Functions

GMAC modules are part of the Gigabit Ethernet Switch Macro and provide the following functions:

- Duplex Modes
  - Each MAC module interface can work in full- or half-duplex mode at any of the provided speeds. The duplex mode can be configured via auto-negotiation (autopolling) or forced by register settings
- Preamble Generation
  - For each Ethernet frame, the MAC generates a preamble and at the Start of Frame Delimiter (SFD). During the generation of preamble and SFD, the pending data is delayed. In receive direction, the preamble and SFD are removed
- FCS Generation and Checking
  - The Frame Checksum (FCS) is a 32-bit CRC checksum that covers the destination address, source address, type field, and the payload data. The FCS of each frame is checked in receive direction and is regenerated in transmit direction. The generation of the FCS for an outgoing frame and the check of the FCS for an incoming frame can be disabled per port.
- Full Duplex Flow Control
  - In case the pause frame based flow control is enabled, the MAC generates a pause frame when a congestion situation is signaled. When this situation occurs while the MAC sends a normal frame, the MAC finishes the current transmission and then sends a pause packet. When the congestion situation ends, the MAC finishes the pending transmission and then sends a pause termination packet. The source address of the pause frames is configurable per switch port. A pause frame is identified by a type/length field of 88 08<sub>H</sub>. The following two bytes provide the opcode field. For pause operation the opcode is 0001<sub>H</sub>. The next two bytes specify the pause length. The pause length is always set to the maximum value of FFFF<sub>H</sub>, which instructs the link partner to seize transmission for 65535<sub>D</sub> slot times. To terminate the pause state, a pause frame with a pause time of 0000<sub>H</sub> is sent, allowing the link partner to resume data transmission. Each time the pause state exceeds the length of 65535<sub>D</sub>/4 = 16384<sub>D</sub> slot times, another pause frame is sent automatically to maintain the pause state.
  - Destination MAC address of the pause frame is 01 80 C2 00 00 01<sub>H</sub>.
  - The default source MAC address of the pause frame is AC 9A 96 00 00 00<sub>H</sub>. This can be changed by configuration.
- Half Duplex Flow Control
  - The flow control in half-duplex mode uses the back-pressure collision mechanism to take control over the media. When a congestion situation is signaled, the received frame is collided and MAC tries to occupy the



line with an egress frame transmission or a special back pressure pattern (in case no data pending for this port). When the congestion situation ends, the MAC resumes normal operation.

- Frame Padding
  - The minimum frame size of an untagged Ethernet frame is 64 byte. The MAC fills all Ethernet egress frames with padding bytes until the minimum frame size requirement is fulfilled. The minimum size is 68 byte for tagged frames (containing a single VLAN tag) and 72 byte for stacked frames (containing two VLAN tags). Frame padding can optionally be disabled for untagged, single or stacked frames separately.
- Jumbo Frame Support
  - The maximum frame size is configurable to support jumbo frames of 9K bytes and below.
- Energy-Efficient Ethernet Functions
  - For power saving purposes, the Low Power Idle (LPI) mode is supported as defined by IEEE 802.3az.
  - Recording of accumulated LPI state time period is supported. A 32-bit counter (accessible via MAC\_LPITMER0 and MAC\_LPITMER1) which counts the period during which the LPI idle state is maintained per port. The unit of the counter is 1 us. It is configurable to count one of the LPI state: RX LPI idle state, TX LPI idle state or both TX and RX in idle state.
- IFG Handling
  - The interframe gap (IFG) can be configured in receive and transmit direction. This allows the acceptance of frames with a short IFG of min. 8-bit times. It is possible to transmit frames with an IFG of 8 to 120 bit times. Typically the IFG is 96 bit times
- The MAC performs several checks on the received frame and signals the following errors. Typically frames with a receive error are discarded but it is also possible to monitor such frames or even ignore the error and process the frame like an error free frame.
  - PHY Error (rx\_error)
  - Alignment Error (align\_err)
  - Length Error (len\_error)
  - Oversized Frame (len\_toolong\_error)
  - Undersized Frame (len\_tooshort\_error)
  - FCS Error (crc\_error)
  - Pause Frame (pause\_frame)

### 3.8.3 VLAN Functions

This section describes VLAN Bridging functionality.

A VLAN is a Virtual Local Area Network, a grouping of network devices logically segmented by functions or applications without regard to the physical location of the devices. Ports in a VLAN share broadcast traffic and belong to the same broadcast domain. Any traffic in one VLAN is by definition not transmitted outside that VLAN. However, there are exceptions to this general rule which can be configured to cover certain system requirements. The following sections provide more details regarding the VLAN functionality.

#### 3.8.3.1 VLAN Association

The VLAN classification function associates each packet received on the ingress side with a specific VLAN group. VLAN association can be performed in one of two ways:

- **Implicit VLAN Association**

The VLAN group is based on packet attributes. When the association is based on the ingress port it is called port-based VLAN. When the association is based on the MAC address, it is called MAC-based VLAN. When the association is based on selected packet header fields (such as Ethernet Type, IP Protocol, IP Address Subnet, MAC Address, etc.), it is called protocol-based VLAN.

- **Explicit VLAN Association**

The VLAN group information is carried in a VLAN tag in the Ethernet header of the received packet. This association is called tag-based VLAN.

#### 3.8.3.2 VLAN QinQ

IEEE 802.1QinQ is an Ethernet networking standard formally known as IEEE 802.1ad and is an amendment to IEEE standard IEEE 802.1Q-1998. It is for Ethernet frame formats. The technique is also known as provider bridging, stacked VLANs or simply QinQ or Q-in-Q. The idea is to provide, for example, the possibility for customers to run their own VLANs inside service provider's provided VLAN. This way the service provider can just configure one VLAN for the customer and customer can then treat that VLAN as if it was a trunk.

The original 802.1Q specification allows a single VLAN header to be inserted into an Ethernet frame. QinQ allows multiple VLAN headers to be inserted into a single frame.

In this context, a QinQ frame is a frame that has two VLAN 802.1Q headers (double-tagged). A tag stack creates a mechanism for Internet Service Providers to encapsulate customer tagged 802.1Q traffic with service provider tag, the final frame being a QinQ frame.

A STAG (Service VLAN Tag) frame is identified by assignable Protocol Type value (typically 88A8<sub>H</sub>, but programmable) and followed by two bytes of TCI field. TCI field consists of 3-bit Priority Code Point (PCP) field, 1-bit Drop Eligible Indicator (DEI) and 12-bit VLAN Identifier field (VID).

A CTAG (Customer VLAN Tag) frame is identified by an Protocol Type value (typically 8100<sub>H</sub>, but programmable) and followed by two bytes of TCI field. TCI field consists of 3-bit Priority Code Point (PCP) field, 1-bit Canonical Format Indicator (CFI) and 12-bit VLAN Identifier field (VID).

### 3.8.3.3 Supported Frame Format

STAG can be configured to be enabled or disabled per port via STEN bit in PCE\_PCTRL\_2.

**Figure 26** shows the supported frame formats when STAG is enabled on a port.

**Figure 27** shows the supported frame formats when STAG is not enabled on a port.

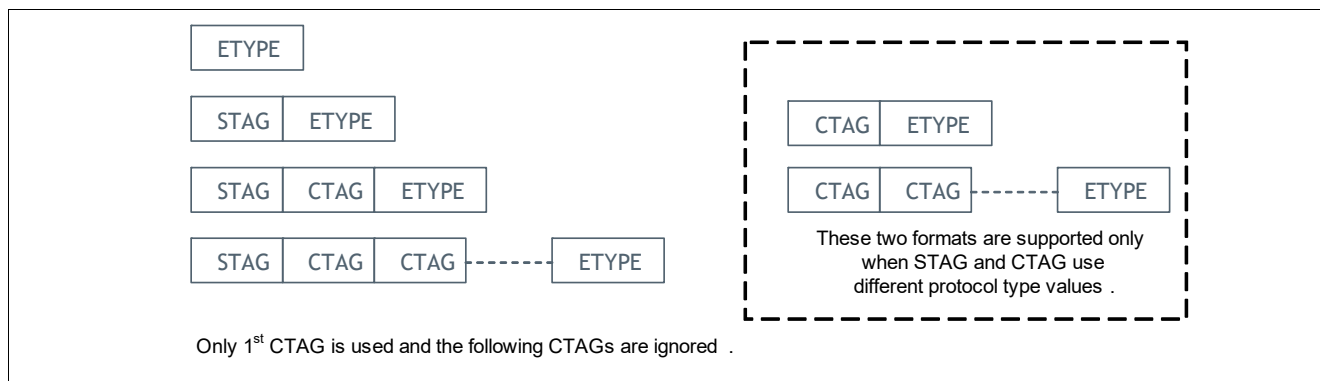

**Figure 26 Supported Frame Formats when STAG is enabled**



**Figure 27 Supported Frame Formats when STAG is disabled**

### 3.8.3.4 Double VLAN Tag Function

Double tag VLAN function is supported. Double VLAN mode is enabled via setting VLANMD bit in PCE\_GCTRL\_1 to 1<sub>B</sub>.

For every packet, there are two VLAN groups: STAG VLAN group and CTAG VLAN group.

STAG VLAN group can determine when CTAG VLAN group is ignored or not.

- When CTAG VLAN group is ignored, then CTAG VLAN is treated as payload, CTAG filtering, CTAG insertion and CTAG removal are not performed.
- When CTAG VLAN group is not ignored, CTAG filtering, CTAG insertion and CTAG removal are performed together with STAG filtering, insertion and removal. Both CTAG filtering and STAG filtering apply on the packet.

### 3.8.3.5 Filtering Identifier Assignment

Single or multiple VLAN groups can be assigned to the same Filtering Identifier (FID) or to different FIDs. There are the following ways to map the traffic to FID.

- Default customer VLAN ID (either ingress port CTAG VID or ingress STAG VID)
- Packet multiple fields via the traffic flow classification
  - A packet is associated to an alternative FID based on multiple fields of a packet, for example, ingress port, service VLAN Tag VID, customer VLAN Tag VID, Source MAC, Destination MAC, source IP, destination IP, etc. See [Section 3.8.6](#) for more details regarding traffic flow classification.

See [Shared/Independent VLAN Learning](#) for details on the shared/independent VLAN learning functionality.

### 3.8.3.6 VLAN Filtering

Received frame can be forwarded or discarded based on the VLAN group configuration and configured port attributes. The following sections describe the available filtering modes that can be applied.

#### CTAG and STAG Ingress Admit Mode

This mode is applied to ports to limit the ingress traffic to a certain profile, with respect to the embedded STAG and CTAG. The following filtering rules are relevant for both STAG and CTAG. There are separate mode configurations for STAG and CTAG. In case of contradiction, the discard rule has higher priority. For example, when according to CTAG filtering the frame is to be discarded and according to STAG filtering is to be admitted, the final rule is to discard the frame:

- Admit VLAN tagged frames only  
Only Ethernet frames that contain a VLAN tag in the Ethernet header are allowed on this port. When a received frame does not contain a VLAN tag, the frame is discarded.  
*Note: Priority tag (VID=000<sub>H</sub>) is not regarded as a VLAN tag, since it contains no explicit VLAN group. Priority tagged frames are discarded in this mode.*
- Admit untagged frames only  
Only packets containing no VLAN tag or containing a priority tag only (VID=000<sub>H</sub>) are allowed on this port. When a received frame contains a VLAN tag, the frame is discarded.
- Admit all  
Both tagged and untagged frames are allowed on the port.

The STAG ingress admit mode is configurable via SVINR field in PCE\_VCTRL of each port. The CTAG ingress admit mode is configurable via VINR field in PCE\_VCTRL of each port.

#### STAG VLAN Group and CTAG VLAN Group Port Members

The port members identify the group broadcast domain. The broadcast domain of the received packet is restricted according to the VLAN membership ports and is delivered only on ports belonging to the same broadcast domain.

The STAG VLAN group membership is configured via traffic flow classification action for the matched STAG VLAN group association. The CTAG VLAN group membership is configured via CTAG VLAN membership table.

By default, both STAG VLAN filtering and CTAG VLAN filtering apply. In case of contradiction, the discard rule has higher priority. For example, when according to CTAG filtering a port is not in the port member list, and according to STAG filtering the port is in the port member list, the final rule is that the port is not in the port member list. But the STAG VLAN group can determine whether the CTAG VLAN group is ignored or not. This is configured via traffic flow classification action for the matched STAG VLAN group association. When the CTAG VLAN group is ignored, then CTAG VLAN is treated as payload, CTAG filtering is not performed. See [Section 3.8.6](#) for details regarding traffic flow classification

#### CTAG and STAG Membership Filtering Mode

This mode enforces packet forwarding based on the port members in the associated VLAN group.

- Ingress Membership Filtering Mode  
The ingress port of the received frame is compared with the port members of the associated VLAN group. When this filtering mode is enabled, the packet is discarded when the ingress port is not contained in the port member list. The ingress membership filtering mode for STAG is configurable via SVIMR field in PCE\_VCTRL of each port. The ingress membership filtering mode for CTAG is configurable via VIMR field in PCE\_VCTRL of each port.
- Egress Membership Filtering Mode  
The egress membership filtering is the primary VLAN functionality. The egress port of the frame is compared with the port members of the associated VLAN group. When this filtering mode is enabled, the packet is discarded when the egress port is not contained in the port member list. When the frames are destined to multiple ports (multicast or broadcast packets), ports not included in the VLAN member list are excluded from

transmission and a copy of the frame is not delivered to these ports. The egress membership filtering mode for STAG is configurable via SVEMR field in PCE\_VCTRL of each port. The ingress membership filtering mode for CTAG is configurable via VEMR field in PCE\_VCTRL of each port.

- Ingress and Egress Membership Filtering Mode.

This mode is a combination of the previous two modes. In this mode, both ingress and egress ports are compared with the port member list of the associated VLAN group.

### Cross-VLAN Functionality

The Ethernet frames classified as cross-VLAN ignore any of the VLAN filtering modes for the ingress or egress ports and as such cross the VLAN boundaries.

The cross-VLAN classification is performed as part of the Traffic Flow classification function. See [Section 3.8.6](#) for details.

### 3.8.3.7 VLAN Tagging and Untagging

The tag members identify the group of egress ports on which the frame associated with the VLAN group must be transmitted as a VLAN-tagged frame. In this case, the associated VLAN is used for the VLAN ID of the transmitted frame.

#### STAG VLAN Tagging and Untagging

The ports with STAG VLAN enabled are the tag members of all STAG VLAN group. The STAG can be configured to be enabled or disabled per port via STEN bit in PCE\_PCTRL\_2.

#### CTAG VLAN Tagging and Untagging

The tag members is configured per CTAG VLAN group via VLAN membership table. But the STAG VLAN group can determine whether CTAG VLAN group is ignored or not. This is configured via traffic flow classification action for the matched STAG VLAN group association. When CTAG VLAN group is ignored, then CTAG VLAN is treated as payload, CTAG tagging and untagging is not performed and CTAG is not modified. See [Section 3.8.6](#) for more details regarding to traffic flow classification.

### 3.8.3.8 Transparent VLAN Mode

A port configured to Transparent VLAN Mode (TVM) ignores the explicit VLAN association and treats all received Ethernet frames as untagged frames, regardless of any existing VLAN tag in the Ethernet header. All tagged and untagged traffic on that port is associated with the port-based VLAN group. When the received packet contains a VLAN tag, this tag is treated as a part of the payload. There is separate transparent mode configuration for CTAG and STAG.

When STAG transparent mode is enabled, CTAG must be configured to transparent mode too, otherwise the switch's behavior is undefined. STAG transparent mode is configurable via STVM field in PCE\_VCTRL of each port. CTAG transparent mode is configurable via TVM field in PCE\_PCTRL\_0 of each port.

When transparent VLAN mode is enabled, ingress admit mode must be set to "Admit Untagged Frames Only" or "Admit All", since all frames are treated as if they were untagged frames.

### VLAN Stacking

When TVM is enabled, the VLAN tag member attribute has a slightly different functionality for tagged frames. When the received frame contains a VLAN tag and the egress port is one of the VLAN tag members, the port-based VLAN is added to the frame as an additional outer tag. When the egress port is not one of the tag members, the packet is transmitted without modification, with the original VLAN tag (if any).

### VLAN ID=0 Handling

It is configurable per ingress port when a frame with a VLAN ID=0 (priority tagged frame) must be handled like an untagged frame. When enabled, a priority tagged frame in transparent mode receives a single tag with VID=PVID. When disabled, a priority tagged frame in transparent mode receives a VLAN tag with VID=PVID on top of the priority tag (priority tag is tunneled in the PVID). The PCP of a priority tagged frame is still used even when the frame is handled like an untagged frame. Priority STAG VLAN handling mode is configurable via SVID0 field in PCE\_VCTRL of each port. Priority CTAG VLAN handling mode is configurable via VID0 field in PCE\_VCTRL of each port.

### 3.8.3.9 VLAN Security Mode

When the VLAN security mode is enabled on an ingress port, all tagged and untagged traffic on that port is associated with the port-based VLAN group. There are separate mode configuration for STAG and CTAG. The STAG VLAN security mode is configurable via SVSR field in PCE\_VCTRL of each port. The CTAG VLAN security mode is configurable via VSR field in PCE\_VCTRL of each port.

When the received frame contains a VLAN tag and the egress port is port and tag member of the port-based VLAN group, the port-based VLAN replaces the original VLAN tag in the Ethernet header. When the egress port is port member but not tag member of the port-based VLAN group, the original VLAN tag is stripped prior to transmission. When the frame has been received with more than one VLAN tag, the outer tag is removed.

These are the differences between the TVM and VLAN security mode for tagged packets.

- Egress port is port and tag member of the port-based VLAN
  - Transparent VLAN Mode: The port-based VLAN tag is added in addition to any existing VLAN tag. The number of VLAN tags in the frame is increased by one.
  - VLAN Security Mode: The port-based VLAN tag replaces the existing VLAN tag. The number of VLAN tags in the frame remains the same.
- Egress port is port member but not tag member of the port-based VLAN
  - Transparent VLAN Mode: The frame is transmitted without modification, containing the original VLAN tag. The number of VLAN tags in the frame remains the same.
  - VLAN Security Mode: The original VLAN tag is removed from the frame. The number of VLAN tags in the frame is reduced by one.

### 3.8.3.10 Reserved VLAN Groups

Any VLAN group in the active VLAN set can be assigned to a reserved VLAN group list by setting the reserved indication in VLAN membership table. The VLAN ID of a frame belonging to a reserved VLAN group can be replaced with the port-based VLAN group. When the frame contains a reserved VLAN tag and the egress port is port member and tag member of the port-based VLAN group, the port-based VLAN ID replaces the original VLAN ID in the Ethernet header.

The difference between VLAN Security and Reserved VLAN functions is that VLAN Security is applied on all traffic received on a certain port whereas Reserved VLAN is applied for a specific VLAN group on a certain port.

This feature applies only to CTAG.

### 3.8.3.11 VLAN Translation

Frames received with a certain VLAN ID can be modified on the egress and contain a different VLAN ID. The following sections describe the relevant functions related to the VLAN modification.

*Note: When applying the VLAN modification, the VLAN membership filtering rules are based on the egress (translated) VLAN group.*

#### STAG VLAN Translation

The egress STAG VLAN ID is one of the following:

- Ingress Port STAG VLAN ID in the following cases
  - Untagged packets
  - Ingress port is in STAG transparent mode
  - Ingress port is in STAG security mode
- Ingress STAG VLAN ID in the following cases
  - Tagged packets when the ingress port is not in transparent mode and not in security mode
- Alternative STAG VLAN ID
  - Alternative STAG VLAN ID is configured via traffic flow classification action for the matched STAG VLAN group association

#### CTAG VLAN Translation

The egress CTAG VLAN ID is one of the following:

- Ingress Port CTAG VLAN ID in the following cases
  - Untagged packets
  - Ingress port is in CTAG transparent mode
  - Ingress port is in CTAG security mode
  - The ingress CTAG VLAN ID is a reserved VLAN group ID
- Ingress CTAG VLAN ID in the following cases
  - Tagged packets when the ingress port is not in transparent mode, not in security mode and the not reserved VLAN group
- Alternative CTAG VLAN ID
  - Alternative CTAG VLAN ID is configured via traffic flow classification action for the matched CTAG VLAN group association

### 3.8.3.12 VLAN Priority Code Point

A dedicated Class of Service (CoS) is assigned based on either Service TAG VLAN Priority Code Point (PCP) and Drop Eligibility Indication (DEI) or Customer TAG VLAN Priority Code Point in the received VLAN-tagged frames. CTAG PCP, STAG PCP and DEI can be regenerated for tagged frames or generated for untagged frames, based on the CoS assigned to that packet.

See [Chapter 3.8.5](#) for details regarding the CoS assignment and PCP&DEI generation and re-generation.

### 3.8.3.13 Port Based VLAN Examples

For a port-based VLAN group, the VLAN association is based on the ingress port number.

Every ingress port is configured with a port-based VLAN ID (PVID). The configured PVID must be part of the active VLAN set. Ingress ports configured with the same PVID belong to the same VLAN group. Any untagged packet received on a port is associated, by default, with the port-based VLAN group configured for that port.

#### Port-based VLAN Example

**Figure 28** shows an example where four LAN stations are connected to a single 4-port switch device. Two VLAN groups are set up with two port members for each group. The active VLAN set contains two groups: port 0 and port 1 are members of VID = 10, port 2 and port 3 are members of VID = 11. Ethernet frames are exchanged between port 0 and port 1 as well as between port 2 and port 3, but not between port 0/1 and port 2/3.

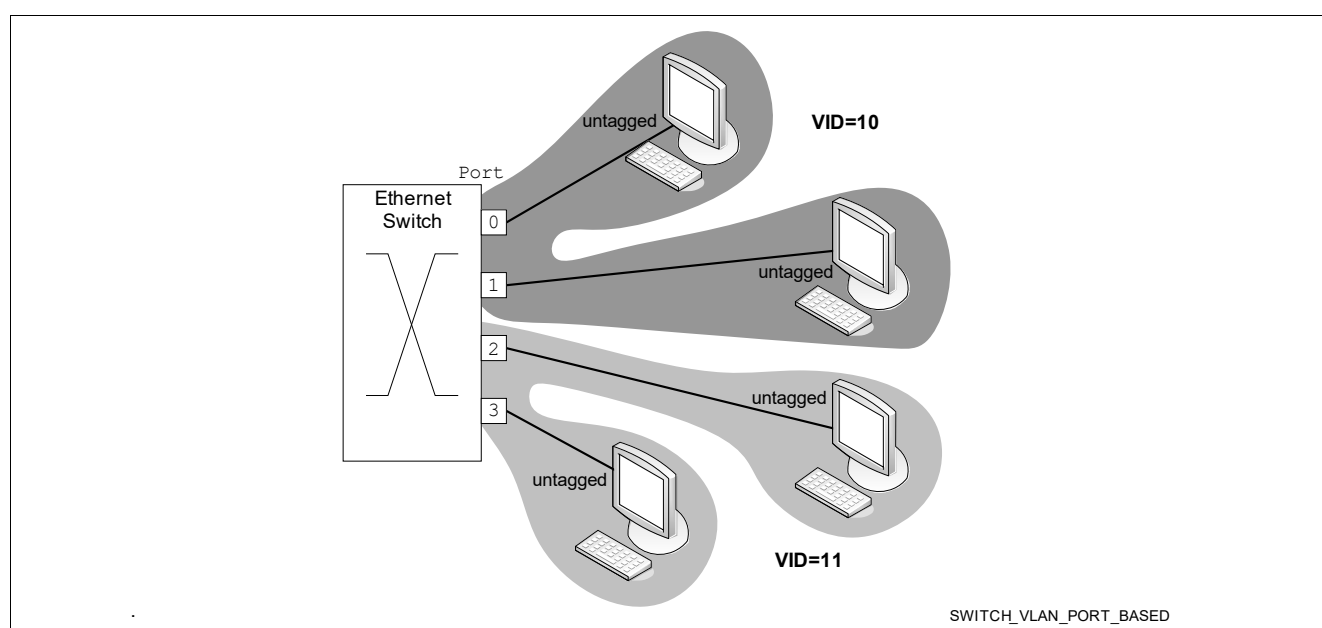

**Figure 28** Port-based VLAN Example

### 3.8.3.14 Single Tag Based VLAN Examples

In a tag-based VLAN group, the VLAN association is based on the outer customer VLAN tag detected in the header of the received Ethernet frame.

#### Tag-based VLAN Example

**Figure 29** shows an example where six LAN stations are connected to a single 6-port switch device. Three VLAN groups are added to the active VLAN set. Port 0 and port 1 are members of the port-based VLAN group with VID = 10, port 2 and port 3 are members of the port-based VLAN group with VID = 11. Port 4 is member of the port-based VLAN group with VID = 12. Port 5 is connected to a server and may transmit and receive tagged VLAN packets of any of the defined groups.

Every configured VLAN group adds port 5 as a port and tag member. In this case, packets received from one of the untagged (VLAN unaware) LAN segments are transmitted as tagged Ethernet frames when they are targeted to port 5. The attached VLAN tag is the port-based VID of the ingress port.



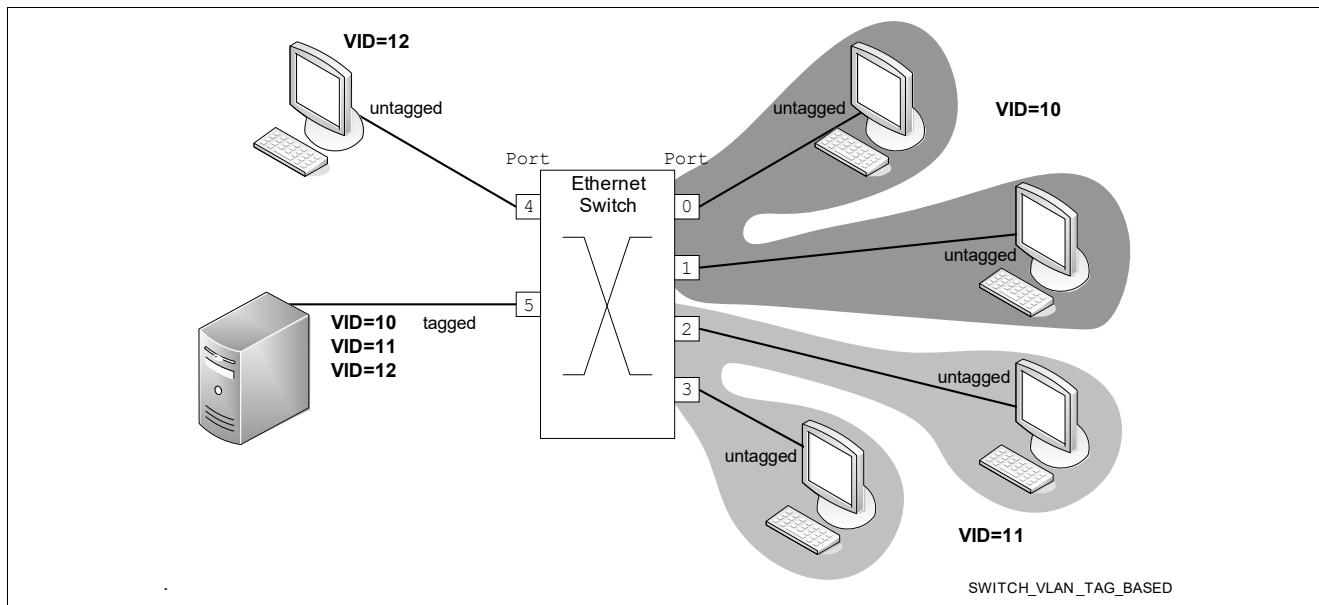

Figure 29 Tag-based VLAN Example

### 3.8.3.15 Double Tag Based VLAN Examples

In a double tag-based VLAN group, the VLAN association is based on STAG and CTAG detected in the header of the received Ethernet frame.

Figure 30 shows an example where six LAN stations are connected to a single 6-port switch device. Port 5 is connected to a server and may transmit and receive double tagged VLAN packets of any of the defined groups.

Table 27 Port Settings

| Port | Port STAG Enable | Port SVID  | CTAG Transparent Mode | Port CVID  |
|------|------------------|------------|-----------------------|------------|
| 0,1  | Disable          | 301        | No                    | Don't Care |
| 2,3  | Disable          | 302        | Yes                   | 11         |
| 4    | Disable          | 301        | Yes                   | 12         |
| 5    | Enable           | Don't Care | No                    | Don't Care |

Table 28 CTAG VLAN Membership Table

| CTAG VLAN ID | CTAG Port Members | CTAG Tag Members |
|--------------|-------------------|------------------|
| 10           | 0, 1, 5           | 0,1,5            |
| 12           | 4, 5              | 5                |
| 11           | 2,3,5             | Null             |

Table 29 Traffic Flow Table

| STAG VID Pattern | Port Bitmap Action | Port Bitmap Multiplexing Control | Port Bitmap <sup>1)</sup> | VLAN Action    | CTAG Ignore Control          |
|------------------|--------------------|----------------------------------|---------------------------|----------------|------------------------------|
| 301              | 1 <sub>B</sub>     | 1 <sub>B</sub> <sup>1)</sup>     | 0,1,4,5                   | 0 <sub>B</sub> | Don't care                   |
| 302              | 1 <sub>B</sub>     | 1 <sub>B</sub> <sup>1)</sup>     | 2,3,5                     | 1 <sub>B</sub> | 1 <sub>B</sub> <sup>2)</sup> |

1) When Port Bitmap Multiplexing Control is 1<sub>B</sub>, Port BitMap is used as STAG Port Members.

2) When CTAG Ignore Control is 1<sub>B</sub>, CTAG VLAN group is ignored and CTAG is treated as transparent.

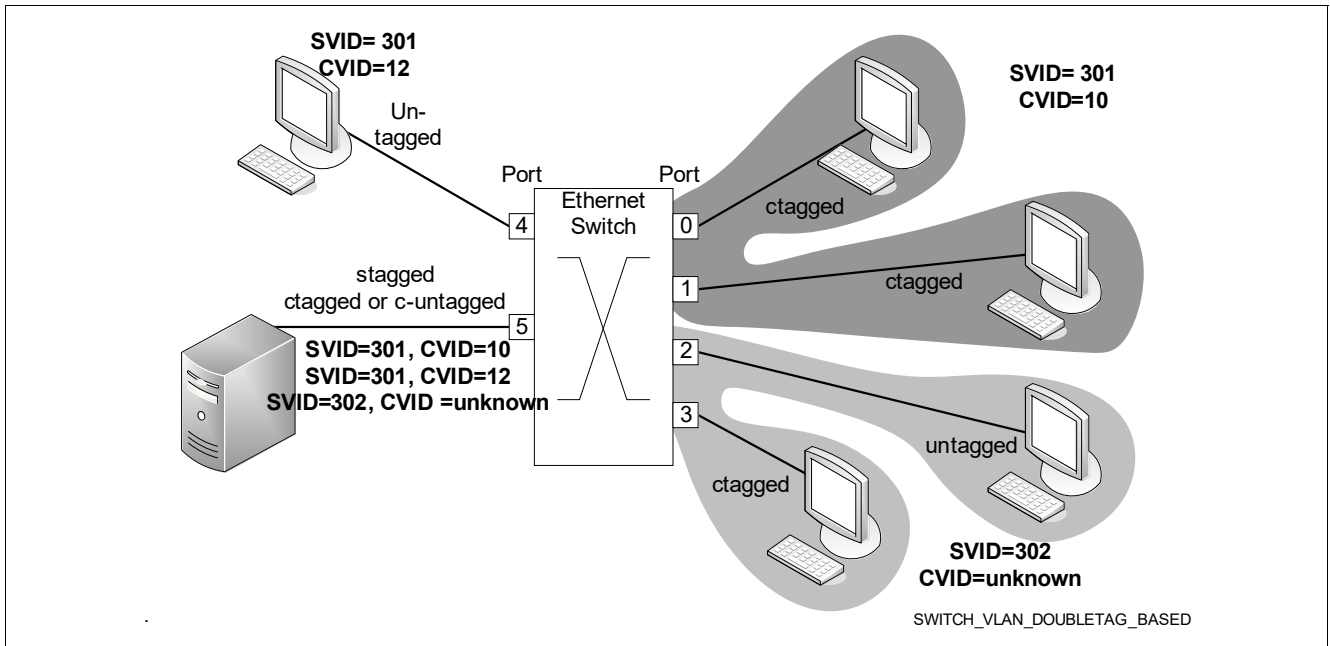

Figure 30 Double Tag and Port based VLAN Example

### 3.8.4 Multicast Forwarding Functions

Multicast forwarding is a method of forwarding Ethernet frames or IP datagrams to a group of receivers. A basic Ethernet switch floods all received multicast frames to all output ports even when no host on a port is interested in that particular multicast stream. This waste of bandwidth is avoided by the sophisticated multicast handling of the Gigabit Ethernet Switch Macro which allows to forward multicast frames based on L2 or L3 addresses to dedicated ports. In addition the Gigabit Ethernet Switch Macro is able to learn L3 multicast group addresses via IGMPv1/2 snooping in hardware.

The Gigabit Ethernet Switch Macro can be configured to ignore L3 information and forward multicast frames based on MAC destination address only. In this case, L2 multicast addresses must be added to the bridging table with the appropriate port members and is populated by software.

When L3 multicast handling is enabled and the packet contains an IP multicast address, a lookup in the dedicated L3 multicast table is performed. The frame is forwarded to the destination port (or multiple destinations) based on the match result. When the frame contains no IP multicast address or when there was no match in the L3 multicast table, a lookup based on the MAC address is done in the bridging table. A lookup match results in a port map which indicates relevant destination ports. [Table 30](#) describes frame forwarding decision. When there was no match in the bridging table, the non-IP multicast frame is forwarded according to the default multicast port map (via PCE\_PMAP\_2). When there is no match in bridging table and no match in L3 multicast table, the IP multicast data frame (IP protocol is not IGMP and MLD) is discarded or forwarded to default multicast port map. IGMP or MLD message frames are forwarded according to IGMP/MLD types.

*Note: The lookup in the L2 bridging tables is done with the MAC address regardless whether the address is a unicast, multicast or broadcast address. This means that a mix of unicast, multicast and broad cast entries can be entered into the tables and that unicast addresses can also be forwarded to multiple ports. The lookup in the IP multicast table is done with the IP address only when the address is IP multicast.*

**Table 30 Multicast Forwarding Decision**

| Forwarding Mode | Packet Type  | L3 Multicast Table             | Bridging Table | Destination Result  |
|-----------------|--|--------------------------------|----------------|---|
| L2 only         | Don't Care   | Don't Care                     | No Match       | Default multicast port map (configured via PCE_PMAP_2).   |
| L2 only         | Don't Care   | Don't Care                     | Match          | Bridging Table, matched entry port members.   |
| L2 / L3         | IGMP/MLD Control                                   | See <a href="#">Table 33</a> . |                |   |
| L2 / L3         | IP Multicast (Excluding IGMP/MLD Control Packets)  | Match                          | Don't Care     | L3 Table, matched entry port members.   |
| L2 / L3         | Any Multicast (Excluding IGMP/MLD Control Packets) | No Match                       | Match          | Bridging Table, matched entry port members.   |
| L2 / L3         | IP Multicast (excluding IGMP/MLD Control Packets)  | No Match                       | No Match       | Two Options (configured via UKIPMC bit in PCE_GCTRL_1):<br>0: Default multicast port map (default mode)<br>1: Discard |
| L2 / L3         | Non-IP Multicast                                   | No Match                       | No Match       | Default multicast port map.   |

The <Informative> IPv4 multicast addresses are in the group historically called Class D, based on the leading bits of these addresses. The group includes the addresses from 224.0.0.0 to 239.255.255.255, or, equivalently, 224.0.0.0/4. The multicast addresses in IPv6 have the prefix ff00::/8<sub>H</sub>. On Layer-2, IPv4 multicast packets are delivered by using the Ethernet MAC address range 01:00:5e:00:00:00<sub>H</sub> - 01:00:5e:7f:ff:ff<sub>H</sub>. This is 23 bits of available address space. The first octet includes the broadcast/multicast bit. The lower 23 bits of the 28-bit

multicast IP address are mapped into the 23 bits of available Ethernet address space. This means that there is ambiguity in delivering packets. When two hosts on the same subnet each subscribe to a different multicast group whose address differs only in the first 5 bits, Ethernet addresses for both multicast groups are the same. For IPv6 The multicast addresses, the Ethernet MAC address is derived by the four low order octets OR'ed with the MAC address 33:33:00:00:00:00<sub>H</sub>.

#### **3.8.4.1 Layer-2 Multicast Forwarding**

The layer-2 multicast forwarding function deals with multicast frame forwarding based on the Ethernet MAC address. The destination port map is looked up in the Bridging table. The multicast addresses are not added to the Bridging table by automatic learning function and must be configured manually, by appropriate management action. The associated port map contains all the relevant port members. When the destination MAC address of the received frame matches the entry in the Bridging table and the Forwarding Mode is Layer-2 only or there was no match in the Layer-3 multicast table or the packet is Non-IP multicast, the frame is delivered to all the destinations specified in the associated port map.

The <Informative> MAC Address is defined as multicast when the least significant bit of the most significant byte is set to “1<sub>B</sub>”. The broadcast Address (MAC address =FF:FF:FF:FF:FF:FF<sub>H</sub>) is a special case and treated in this description as Multicast.

#### **3.8.4.2 Layer-3 Multicast Forwarding**

Layer-3 Multicast function deals with multicast frame forwarding based on the IPv4 or IPv6 Network Address. The destination port map is looked up in the L3 multicast table.

The lookup in the multicast table is performed using the destination IPv4/IPv6 address and optionally the source IPv4/IPv6 address. The addresses in the table are added automatically by hardware based IGMP snooping or by appropriate management action. See [IGMP and MLD Snooping](#) for details. In any source multicast (ASM) as in IGMPv1/IGMPv2/MLDv1, the source IP information is not required, in source specific multicast (SSM) as in IGMPv3/MLDv2 the source IP information is used for the lookup. For SSM, the include and exclude mode is supported. In include mode, the packets are forwarded to the multicast group address when they come from a specified IP source address (or multiple addresses). In exclude mode, the packets are forwarded to the multicast group address when they do not come from a specified IP source addresses.

#### **3.8.4.3 IGMP and MLD Snooping**

The Gigabit Ethernet Switch Macro supports IGMP (Internet Group Management Protocol) and MLD (Multicast Listener Discovery) snooping. IGMP/MLD snooping is designed to prevent hosts on a local network from receiving traffic for a multicast group they have not explicitly joined. It provides a mechanism to prune multicast traffic from links that do not contain a multicast listener (IGMP/MLD group member). IGMP/MLD snooping requires the Gigabit Ethernet Switch Macro to examine, or snoop, some Layer-3 information in the IGMP/MLD packets sent between the hosts and the router. In addition, adjacent routers also use these protocols to communicate and share routing information. This information exchange can be snooped as well to identify the multicast router port.

The Gigabit Ethernet Switch Macro supports HW-based IGMP snooping mode for the IGMPv1/IGMPv2 protocols. In this mode, the L3 multicast addresses are added to the multicast table or removed from it automatically, based on the relevant IGMP reports. No software intervention is required in this mode. See [HW Based IGMP Snooping](#) for details.

The Gigabit Ethernet Switch Macro supports SW-based IGMP/MLD snooping mode for the IGMPv1/2/3 or MLDv1/2 protocols. In this mode, specific IGMP/MLD reports can be intercepted by the switch and delivered to the CPU/Network Processor port. The reports are analyzed by the CPU and the L3 multicast table is populated by the SW with appropriate source/destination addresses. See [SW Based IGMP/MLD Snooping](#) for details.

## HW Based IGMP Snooping

When HW-based IGMP snooping is enabled, the Gigabit Ethernet Switch Macro analyzes all IGMPv1/IGMPv2 packets between hosts connected to the switch and multicast routers in the network. [Table 31](#) and [Table 32](#) describe the packet structure of IGMP messages intercepted by the switch, these patterns are added as a dedicated rule to the Traffic Flow Table. [Table 31](#) describes the messages sent by the multicast host and [Table 32](#) describes the messages sent by the multicast router.

**Table 31 Multicast Host Messages**

| Field               | IGMPv1 Report                 | IGMPv2 Report                 | Leave                          |
|---------------------|-------------------------------|-------------------------------|--------------------------------|
| MAC_DA              | 01 00 5E <sub>H</sub> --IP_DA | 01 00 5E <sub>H</sub> --IP_DA | 01 00 5E 00 00 02 <sub>H</sub> |
| Ethertype           | 0800 <sub>H</sub>             | 0800 <sub>H</sub>             | 0800 <sub>H</sub>              |
| IP Protocol (=IGMP) | 02 <sub>H</sub>               | 02 <sub>H</sub>               | 02 <sub>H</sub>                |
| IP_SA               | Host_IP Address               | Host_IP Address               | Host_IP Address                |
| IP_DA               | Group_IP_Address              | Group_IP_Address              | 224.0.0.2 or Group_IP_Address  |
| Type                | 12 <sub>H</sub>               | 16 <sub>H</sub>               | 17 <sub>H</sub>                |
| Max. Response Time  | 0                             | 0                             | 0                              |
| Group Address       | Group_IP_Address              | Group_IP_Address              | Group_IP_Address               |

**Table 32 Multicast Router Messages**

| Field               | Solicitation                   | Advertisement                  | General Query                  | Group Specific Query          |
|---------------------|--------------------------------|--------------------------------|--------------------------------|-------------------------------|
| MAC_DA              | 01 00 5E 00 00 02 <sub>H</sub> | 01 00 5E 00 00 6A <sub>H</sub> | 01 00 5E 00 00 01 <sub>H</sub> | 01 00 5E <sub>H</sub> --IP_DA |
| Ethertype           | 0800 <sub>H</sub>              | 0800 <sub>H</sub>              | 0800 <sub>H</sub>              | 0800 <sub>H</sub>             |
| IP Protocol (=IGMP) | 02 <sub>H</sub>                | 02 <sub>H</sub>                | 02 <sub>H</sub>                | 02 <sub>H</sub>               |
| IP_SA               | Router_IP Address              | Router_IP Address              | Router_IP Address              | Router_IP Address             |
| IP_DA               | 224.0.0.2                      | 224.0.0.106                    | 224.0.0.1                      | Group_IP_Address              |
| Type                | 31 <sub>H</sub>                | 30 <sub>H</sub>                | 11 <sub>H</sub> <sup>1)</sup>  | 11 <sub>H</sub>               |

1) For IGMPv1 the type = 1 but together with the version = 1 a IGMPv2 host sees 11<sub>H</sub>

When the switch detects an IGMP report or join group message sent from a host for a given multicast group, the switch adds the host's port number to the multicast table entry for that group. When a IGMP leave group message is received from a host, the host's port number is removed from the appropriate table entry when fast leave (also called immediate leave) mode is enabled. See the following sections for details.

### Joining Multicast Group:

When the Gigabit Ethernet Switch Macro receives a host membership report on one of the ingress ports and HW-based IGMP snooping is enabled, this port is added to the specified multicast group in the L3 multicast table. When there was no such group entry in the table, a new entry is created with the appropriate group IP address. Received membership report is forwarded to the multicast router port (or multiple router ports).

### Report Suppression:

The Gigabit Ethernet Switch Macro supports suppression of membership reports or join messages to reduce processing load of the multicast router. When report suppression is enabled, only the first report for specific group is forwarded to the router port. The rest of the reports from the other hosts are discarded. The suppression can be configured per port and can be selected separately for join or report messages.

Join message is an IGMP membership report from a host that previously did not participate in a group.

#### Leaving Multicast Group:

When a host wants to leave a multicast group it can send a Leave message (IGMPv2) or should not send a Report message after a Query (IGMPv1). A Leave message is sent to the all-routers multicast group (224.0.0.2) or to the group a host wants to leave.

Each port in the joined group maintains an aging timer. Repeated Reports refresh the timer. When no Reports are received for a particular group before this timer expires, the router assumes the group has no local members and does not require forward multicast frames for that group. Robustness variable is supported and determines how often the response timer is allowed to expire before the port is actually deleted. When the port map becomes zero the whole entry is deleted from the L3 multicast HW table. The response timer is reset each time a new query was received.

The age time for the entries is derived from the response time received in the IGMP Query messages. For a group specific query the response time is used only for the corresponding group, for a general query the response time is used for all the groups. It can be programmed that the default response time is used instead of the response time from the query message.

The Gigabit Ethernet Switch Macro supports a fast leave (also called immediate leave) feature. When fast leave is enabled and an IGMP Leave is received, the port from which the IGMP packet was received is cleared immediately from the port map of the corresponding group IP address. When the port map is empty, the group IP address and port map are deleted from the L3 multicast HW table. When fast leave is not enabled, the ports and group IP addresses age out when no reports have been detected for a given time.

*Note: Enable fast leave mode where only one host is connected to each interface. When fast-leave is enabled where more than one host is connected to an interface, some hosts might be dropped inadvertently.*

#### Router Port Detection:

The Gigabit Ethernet Switch Macro supports automatic detection of the multicast router port, based on the typical multicast router messages described in [Table 32](#). When router port detection (auto-learning) is enabled, the learned router port is added as a destination to the snooped IGMP reports received from hosts and as a destination to any multicast frame destined to the hosts.

The default Router Port can also be configured by appropriate management action.

Each learned router port (or multiple ports) maintains an aging timer and can age out when the router message exchange is stopped on a port. The timer is automatically reset each time a new router message is received. When a port does not receive any router messages within the specified time period, the port is deleted from the learned router port map.

#### Multicast Steam Forwarding:

[Table 33](#) describes typical forwarding destination for the multicast frames. Multicast data frames are typically received from the router port and forwarded based on the match in the L3 multicast table and to the router ports. When there was no match in the L3 multicast table the frames are forwarded based on the L2 addresses or to the default IP/IGMP multicast port map.

**Table 33 Typical IGMP/MLD Control Packets Forwarding Destination**

| IGMP Message Name                             | Port Map  |
|---|---|
| Report  | Multicast router port map   |
| Leave   | Multicast router port map   |
| General Query or Group Specific Query         | Forwarding port map (based on L3 or L2 multicast table) + Multicast router port map |
| Unknown General Query or Group Specific Query | Default multicast port map+ Multicast router port map                               |

### SW Based IGMP/MLD Snooping

When SW-based IGMP snooping is enabled, IGMP/MLD control frames from Non-CPU ports are forwarded to the CPU port (IGMP/MLD control frame patterns are added as dedicated rules to the Traffic Flow Table as shown in [Table 34](#)) and the L3 multicast table is populated by software. IPv4 / IPv6 source and destination addresses can be added to the table and specify the direction of the multicast streams. A source address can be added using one of the following modes:

- **Include Mode.** In this mode, the forwarding of the multicast frame is based on the source and destination address pair. Specifically: the frame is forwarded to the specified port map only when both addresses (the source and destination) match in the L3 multicast table.
- **Exclude Mode.** In this mode, the forwarding of the multicast frame is based on destination and source address pair. Specifically: the frame is forwarded to the specified port map only when the source address does not match the address in the table and the destination address matches. When a frame contains specified source and destination address, this frame is discarded. When a frame contains any other source address and a matched destination, this frame is forwarded.

*Note: Adding an entry in exclude mode, creates up to two entries in the L3 multicast table. An exclude entry is implemented using two entries in the include mode: one contains an include entry with the wild-card source address and another an include entry with the respective host port cleared in the port map.*

- **Don't Care Mode.** In this mode, the source IP address field of the packet is ignored and the multicast frame forwarding is based on the destination IP address alone.

**Table 34 IGMP/MLD Messages**

| Field       | IGMPv1/v2/v3<br>Host Messages | IGMPv1/v2/v3<br>Router Messages | MLDv1/v2<br>Host Messages | MLDv1/v2<br>Router Messages |
|-------------|-------------------------------|---------------------------------|---------------------------|-----------------------------|
| IP Type     | IPv4                          | IPv4                            | IPv6                      | IPv6                        |
| IP Protocol | 2                             | 2                               | 58                        | 58                          |
| Type        | 18, 24, 25, 34                | 17, 48, 49                      | 131 - 132                 | 130, 151 - 153              |

**Table 35 Typical IGMP/MLD Messages Forwarding Destination**

| Source Port | IGMP/MLD Message Name | Port Map  |
|-------------|-----------------------|---|
| Non-CPU     | All messages          | CPU Port  |
| CPU         | Host Messages         | Router port map   |
| CPU         | Router Messages       | Forwarding port map (based on L3 or L2 multicast table or default multicast port map) |

### 3.8.5 Quality of Service Functions

The Gigabit Ethernet Switch Macro provides extensive support for Quality of Service functionality. Particularly, traffic class assignment based on multiple flow parameters, ingress traffic policing, multiple egress queues per port with strict or WFQ scheduling, traffic shaping and weighted random early discard (WRED) functions are supported.

The following sections describe in more details the QoS functions supported by the switch.

#### 3.8.5.1 Class of Service Assignment

The Gigabit Ethernet Switch Macro supports classification of the incoming traffic into traffic classes or classes of service (CoS). Each traffic class can be managed (e.g., remarked, policed, shaped) differently, ensuring preferential treatment for higher-priority traffic on the network. The Gigabit Ethernet Switch Macro is able to assign the traffic class of the received packet, based on the following parameters:

- **Ingress Port:** CoS is based on the ingress port number of the received packet. This mode is used by default when no other criteria can be matched.
- **STAG PCP&DEI and CTAG PCP (VLAN Priority Code Point):** CoS is based on the VLAN priority code point placed in the VLAN tag of the incoming packet. The Gigabit Ethernet Switch Macro provides a global STAG PCP&DEI to Traffic Class assignment table and a global CTAG PCP to traffic class assignment table. In the tables, any STAG VLAN PCP/DEI or CTAG VLAN PCP combination is mapped to an appropriate class of service. Traffic class mapping from STAG VLAN PCP/DEI can be enabled per ingress port (via SPCP bit in PCE\_PCTRL\_2). Traffic class mapping from CTAG PCP can be enabled per ingress port (via PCP bit in PCE\_PCTRL\_2).
  - When the packet contains no STAG it can be configured to choose other methods for the traffic class classification (e.g., DSCP, CTAG PCP, or ingress port).
  - When the packet contains no CTAG it can be configured to choose other methods for the traffic class classification (e.g., DSCP, STAG PCP&DEI, or ingress port).
- **DSCP (Differentiated Services Code Point):** CoS is based on the Differentiated code point placed in the IP header of the incoming packet. The Gigabit Ethernet Switch Macro provides a global DSCP to traffic class assignment table. In this table any IP DSCP 6 bits combination is mapped to an appropriate class of service. *Note: When the packet contains no IP header it can be configured to choose other methods for the traffic class classification (e.g. CTAG PCP, STAG PCP/DEI or default traffic class).*
  - When more than one classification methods are enabled, the highest traffic class mapped from different fields is selected.
- **Traffic Flow:** Any combination of the following traffic flow parameters entered to the Traffic Flow table can be used to assign the class of service. When a flow with an appropriate traffic class assignment action matches for a given ingress frame, this assignment has higher priority over the default CoS assignments. In this case, the traffic class is assigned based on the traffic flow rule.
  - Destination MAC address (with nibble-mask support)
  - Source MAC address (with nibble-mask support)
  - STAG VLAN ID (with nibble mask or range support)
  - CTAG VLAN ID (with nibble mask or range support)
  - Ethertype
  - IP protocol and parser flags
  - IP packet length or length range
  - STAG PCP & DEI
  - CTAG PCP
  - IP DSCP
  - Source IP address (with nibble-mask support)
  - Destination IP address (with nibble-mask support)
  - Application field 1, for example, Source TCP/UDP port (with range support)
  - Application field 2, for example, Destination TCP/UDP (with range support)



Up to 16 different traffic classes can be supported and mapped individually to appropriate QoS queue. See [Queue Mapping](#) for more details regarding queue mapping. [Figure 31](#) describes the traffic class assignment selection order vs configuration.

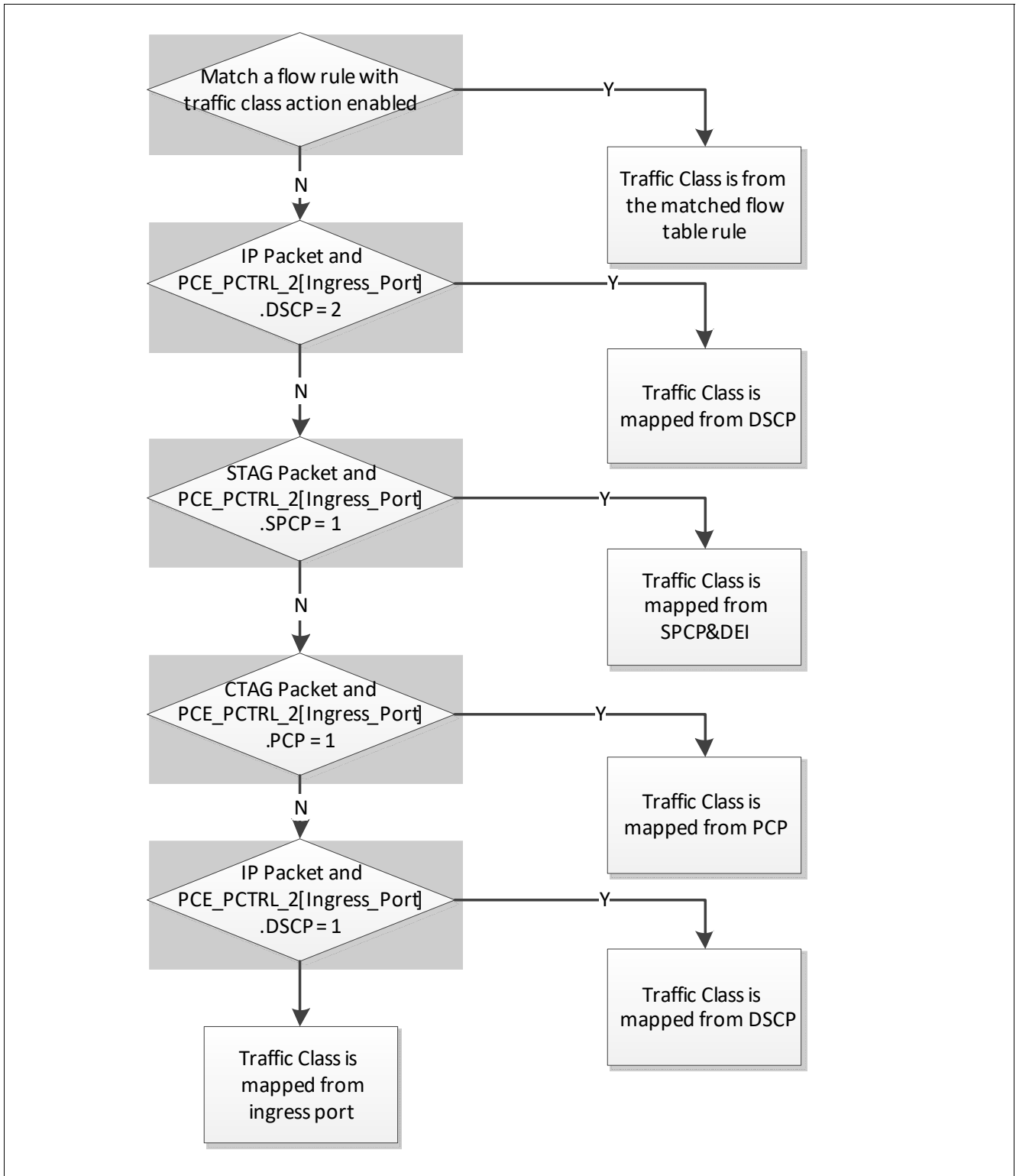

**Figure 31 Traffic Class Assignment**

### 3.8.5.2 Remarking Function

The Gigabit Ethernet Switch Macro supports the remarking of the DSCP, (re)generation of STAG PCP&DEI, and (re)generation of CTAG PCP in the egress frame. The modification of the code points in the outgoing packets is based on both traffic class and egress port. The Gigabit Ethernet Switch Macro provides a dedicated mapping table to assign the new DSCP, CTAG PCP and STAG PCP&DEI according to according to traffic class as well as egress port. **Figure 32** shows how DSCP (including drop precedence), CTAG PCP, STAG PCP and STAG DEI can be remarked based on any of the class of service assignment parameter.

Remarking can be enabled per ingress port. Remarking can also be disabled per egress port and per code point. In addition, the Traffic Flow table allows to disable remarking explicitly for certain flows.

**Figure 33** shows the remarking DSCP flow diagram. **Figure 34** shows the remarking Drop Precedence flow diagram. **Figure 35** shows the STAP PCP remarking flow diagram. **Figure 36** shows the STAP DEI remarking flow diagram. **Figure 37** shows the CTAG PCP remarking flow diagram.

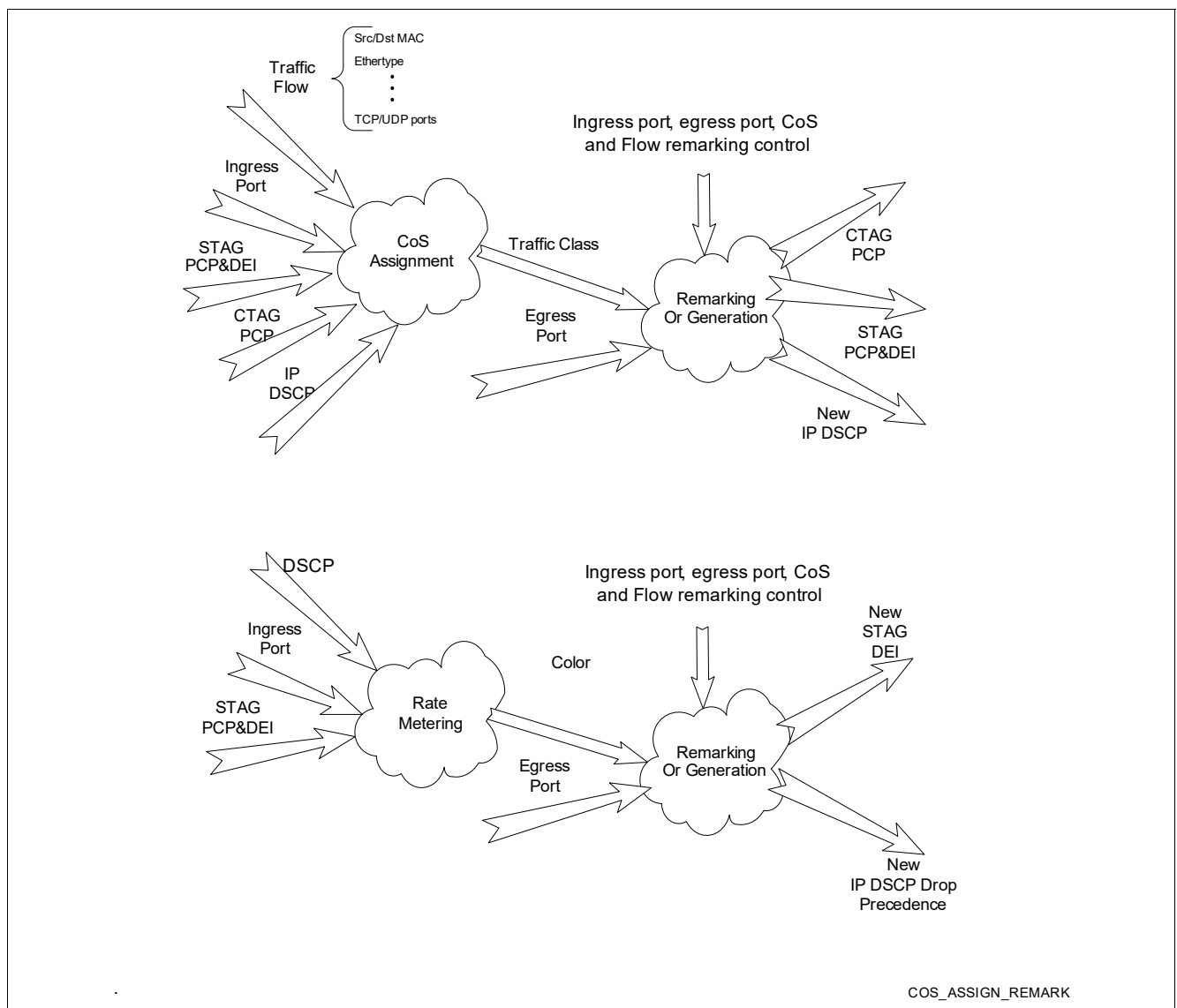

**Figure 32 PCP/DSCP /DEI Remarking**

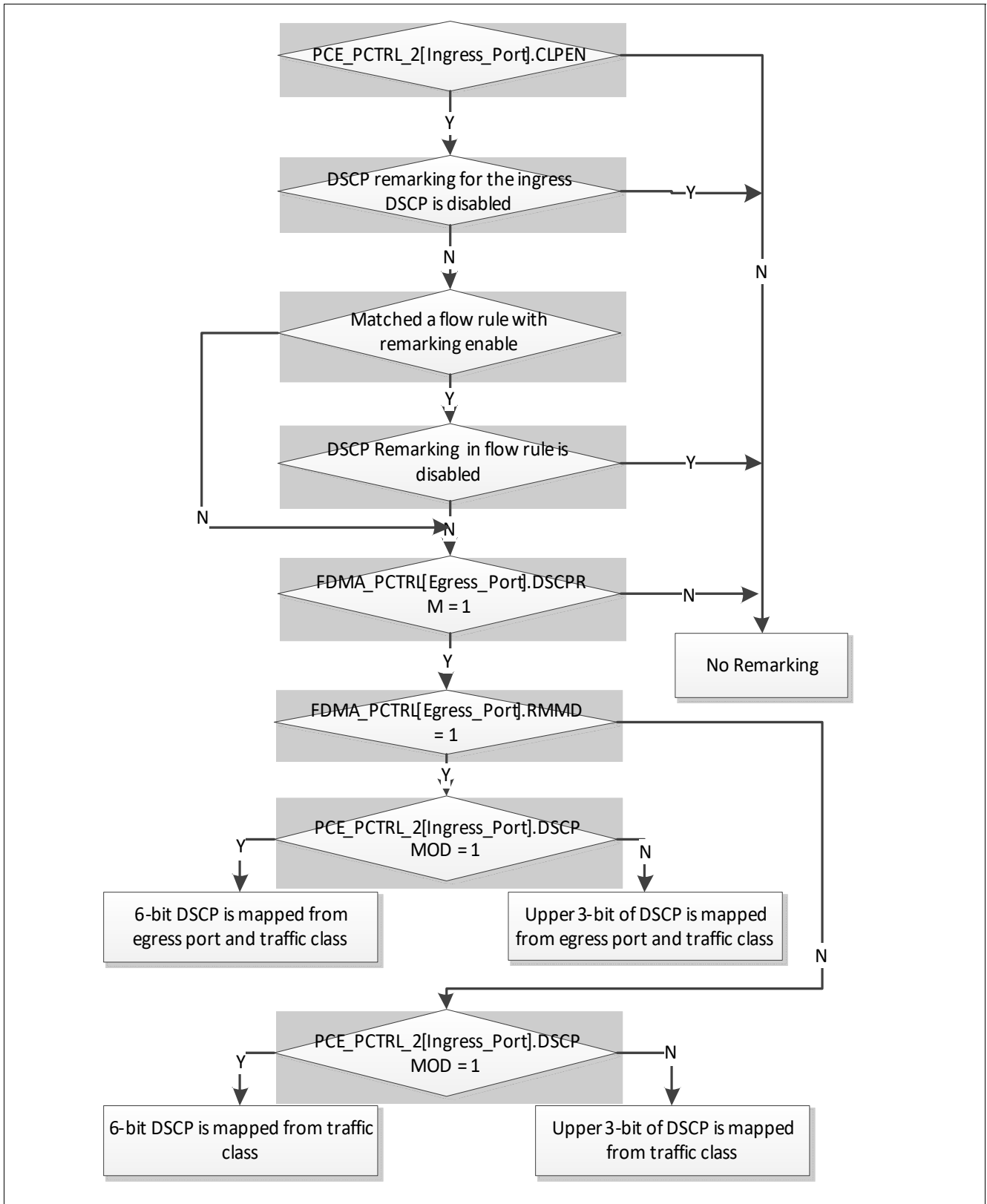

Figure 33 DSCP Remarking Flow Diagram

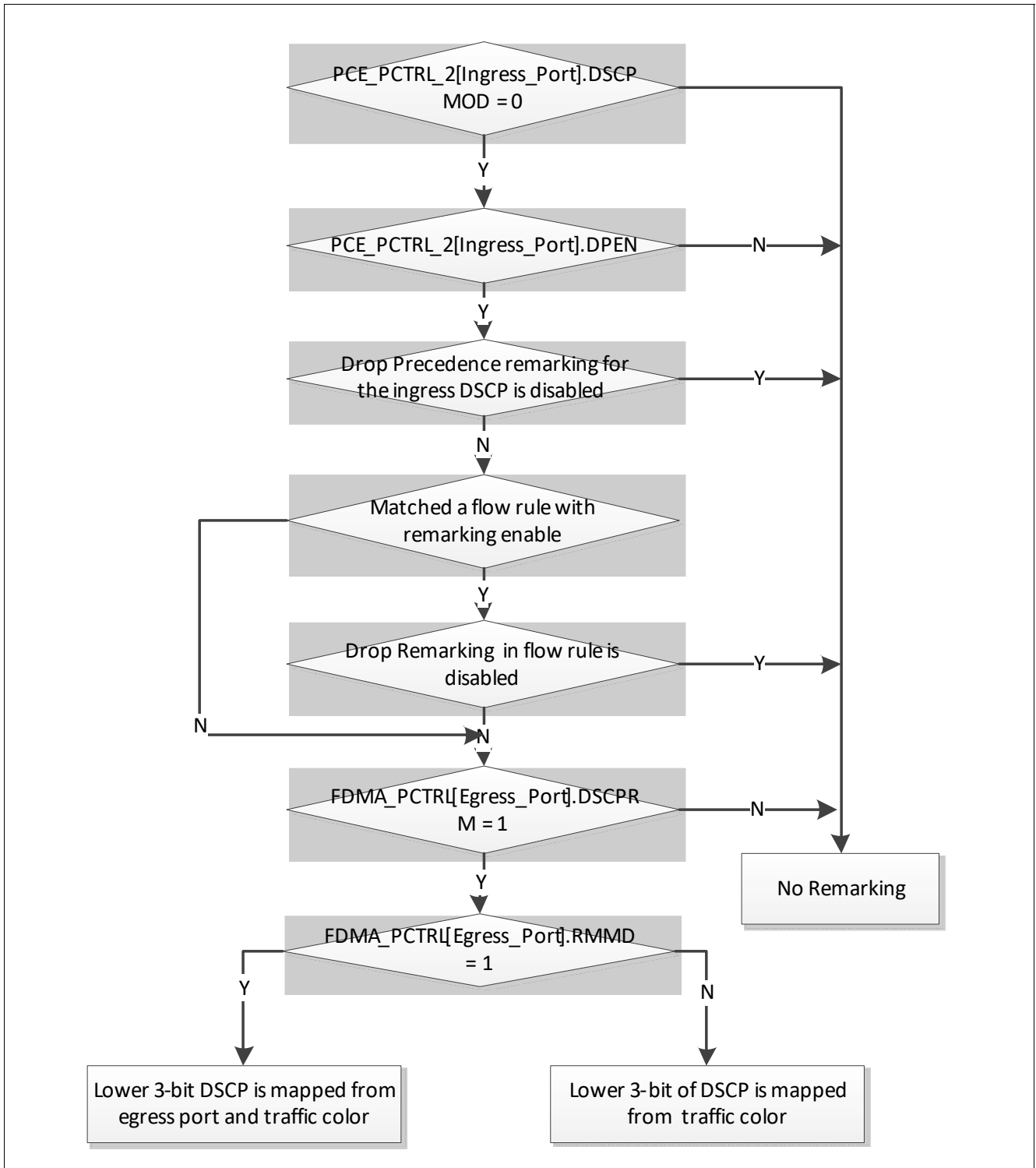

Figure 34 Drop Precedence Remarking Flow Diagram

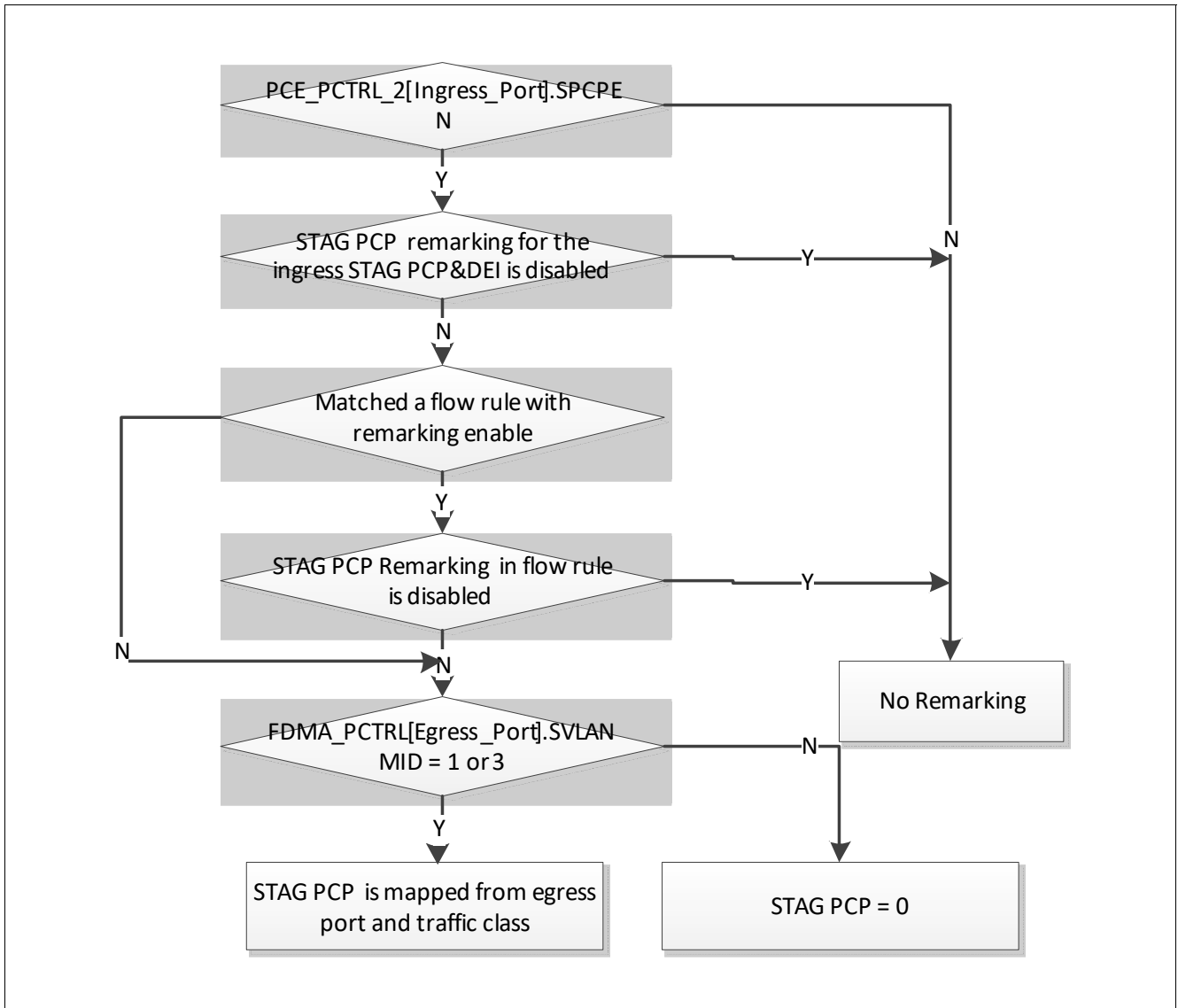

Figure 35 STAG PCP Remarking Flow Diagram

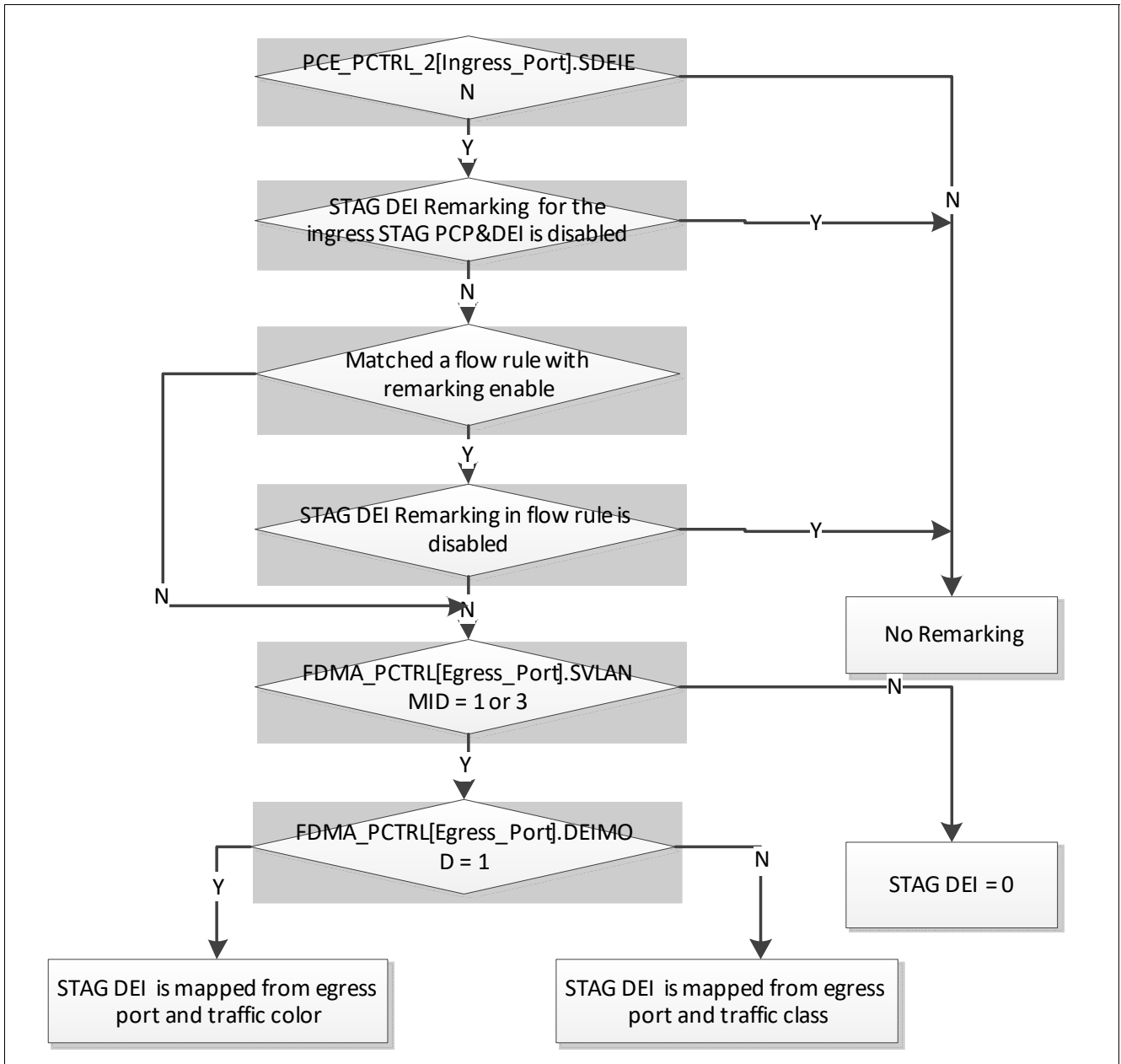

Figure 36 STAG DEI Remarking Flow Diagram

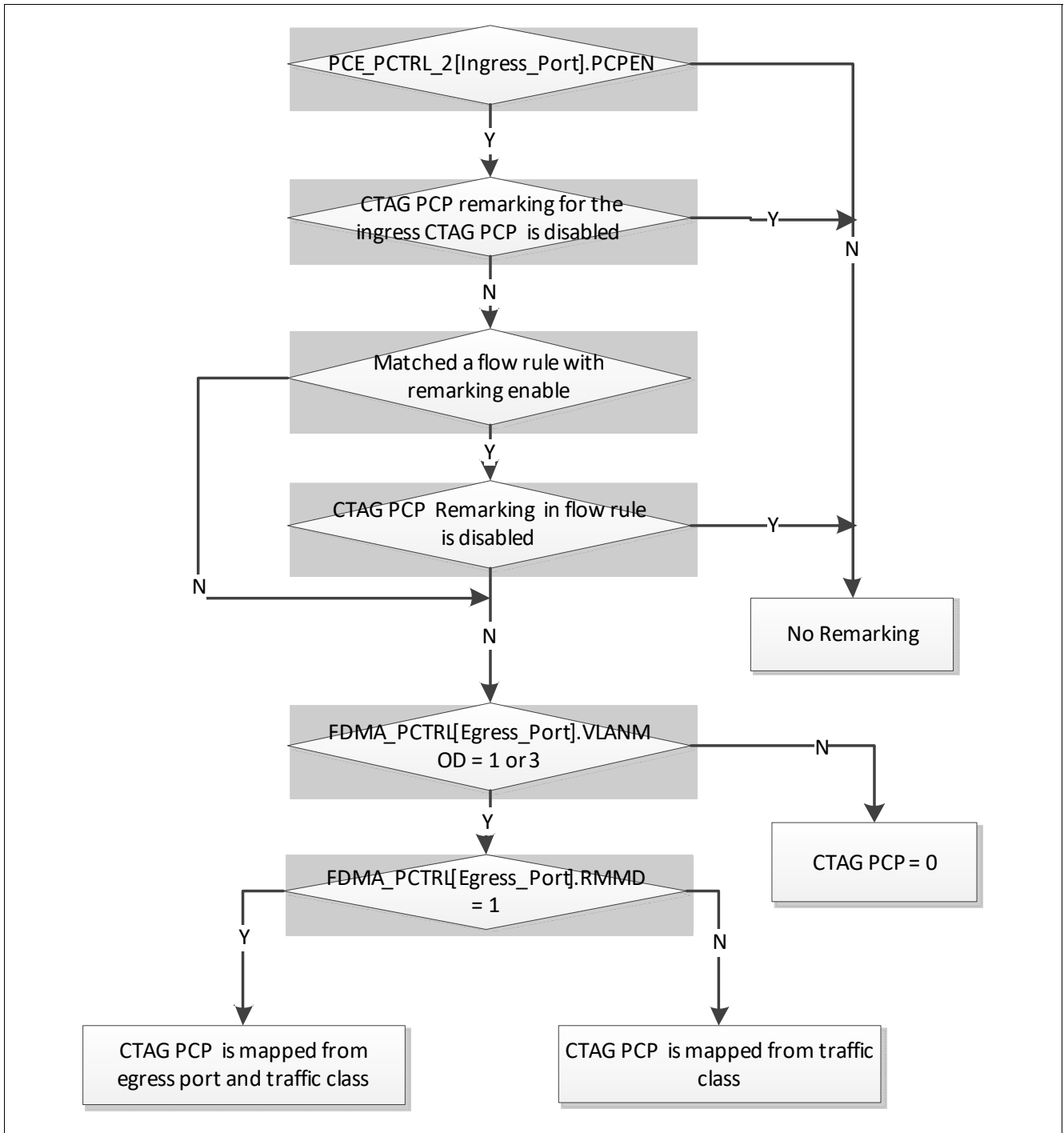

Figure 37 CTAG PCP Remarking Flow Diagram

### 3.8.5.3 Queue Mapping

The Gigabit Ethernet Switch Macro supports 32 egress QoS queues that can be flexibly assigned to egress ports and traffic classes. The following sections provide more details on the queue mapping functionality.

#### Queue to Port Mapping

Per default egress port 0 to 7 has 4 Quality of Service queues. For certain applications it might be desired to have a different number of QoS queues on specific ports. The Gigabit Ethernet Switch Macro supports flexible queue to port mapping. Each queue from the 32 queue pool can be assigned to any port. This way the default configuration can be changed so that one port, for example, contains 8 queues.

*Note: In certain configurations there might be unassigned (unused) queues. However, the overall number of 32 queues for all ports cannot be exceeded.*

In addition, an active port must have at least one queue and can have maximum 16 queues assigned to it.

#### Traffic Class to Queue Mapping

Incoming frames are being stored in the appropriate queues based on the traffic class assignment. The mapping of the traffic class to queue is specified in a dedicated queue mapping table per egress port. The mapping of the traffic classes to queues is related to the number of the queues available on certain port. For example, on one port 4 traffic classes could be mapped to 4 different queues, on another port all 4 traffic classes could be mapped to one single queue of this port.

### 3.8.5.4 Rate Metering

The Gigabit Ethernet Switch Macro supports 16 instances of a single rate Three Color Meter (srTCM). Each meter can measure the rate of a packet stream and mark the packets either green, yellow, or red. When there is no metering instance assigned to a traffic stream, this stream is considered to be green in the color-blind mode. In color-aware mode the stream is colored based on the drop-precedence encoded in the frame. See the following sections for details.

The color markings can be used later for policing in the active congestion management function, See [Congestion Management](#) for details. In addition the markings can be used to remark the drop precedence of the outgoing packet in the DSCP and STAG DEI.

Marking is based on a Committed Information Rate (CIR) and two associated burst sizes, a Committed Burst Size (CBS) and an Excess Burst Size (EBS). A packet is marked green when it does not exceed the CBS, yellow when it does exceed the CBS, but not the EBS, and red otherwise.

*Note: In color-aware mode as described in [Color-aware/ Color-blind modes](#), the packet may already contain a color. In this case, for a yellow colored frame only the EBS is checked and when exceeded, the packet becomes red. For packets received with a red color - the CBS/EBS plays no role, the packet remains red.*

Only single meter instance can be assigned to measure the rate of a traffic flow.

The Gigabit Ethernet Switch Macro supports the following meter assignments:

- **Port:** A Meter can be assigned to the ingress or egress port or port pair, particularly:
  - Ingress port. The meter assigned to a specific ingress port. All packets received on that port are metered with the same meter instance.
  - Egress port. The meter assigned to a specific egress port. Any packets destined to that port are metered with the same meter instance.
 

*Note: The multicast packets get metered when a meter is assigned to one of the destination ports.*
  - Ingress-Egress port pair. The meter assigned to a specific packet route, from specific ingress port to a specific egress port.
- **Traffic Flow:** Any combination of the following traffic flow parameters entered to the Traffic Flow table can be used to assign the metering instances.



- Destination MAC address (with nibble-mask support)
- Source MAC address (with nibble-mask support)
- STAG VLAN ID (with nibble mask or range support)
- CTAG VLAN ID (with nibble mask or range support)
- Ethertype
- IP protocol and parser flags
- IP packet length or length range
- STAG PCP & DEI
- CTAG PCP
- IP DSCP
- Source IP address (with nibble-mask support)
- Destination IP address (with nibble-mask support)
- Application field 1, for example, Source TCP/UDP port (with range support)
- Application field 2, for example, Destination TCP/UDP (with range support)
- **Storm Control:** (refer also to **Storm Control**) When storm control is enabled a meter can be assigned to
  - unknown unicast traffic
  - unknown multicast traffic
  - broadcast traffic

Figure 38 describes a metering algorithm of a single metering instance.

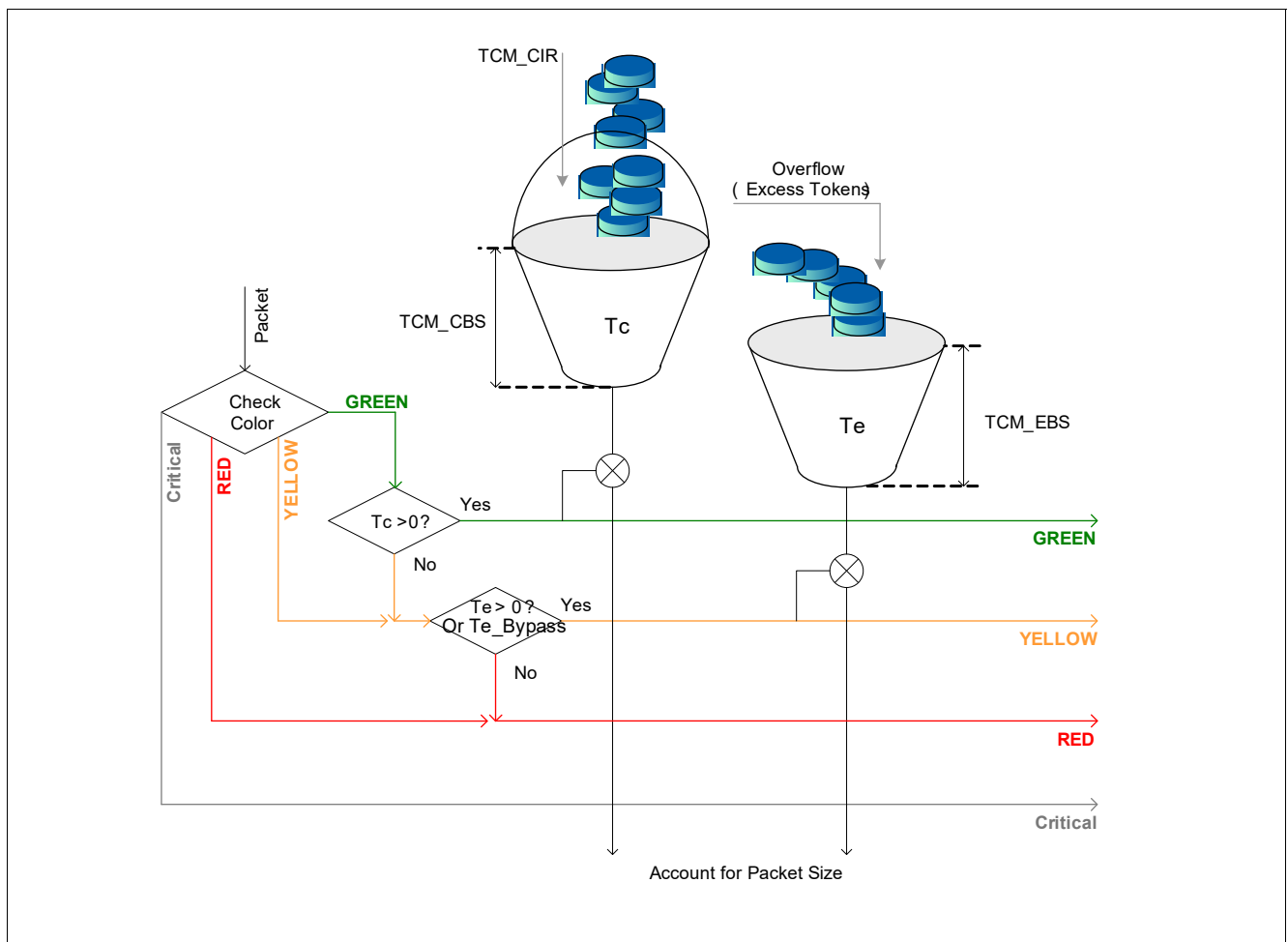

Figure 38 Metering Algorithm

### Critical Frames

Frame can be classified as critical based on specific DSCP encoding in the appropriate DSCP mapping table or based on a rule configured in the Traffic Flow table. Critical frames bypass the metering instance and do not trigger the active congestion management function.

### Color-aware/ Color-blind modes

The Gigabit Ethernet Switch Macro supports color-awareness modes to be configured per ingress port. In the color-aware mode, the meter assumes that some preceding entity has pre-colored the incoming packet stream so that each packet is either green, yellow, or red. The ingress color of the incoming frame is based on either DSCP value or STAG PCP&DEI value. It is retrieved from the appropriate DSCP mapping table or STAG PCP&DEI mapping table. Non-IP and Non-STAG packets are treated as pre-colored to green.

In color-blind mode, all packets are treated as green.

### DSCP Drop Precedence Remarking

It can be enabled by both ingress port and egress port configuration to reflect the metering results by replacing the lower 3 bits of the received DSCP field with the value of appropriate color decided by the metering instance for the received packet. The mapping of the color to the lower 3 bits of the DSCP can be configured per egress port. See [Remarking Function](#) for details.

### DEI (Re)generation

It is enabled by both ingress port and egress port configuration to reflect the metering result by setting the STAG DEI field of the packet with the value of appropriate color decided by the metering instance for the received packet. The mapping of the color to the DEI is configured per egress port. See [Remarking Function](#) for details.

### Metering based Flow Control

When a metering instance is assigned to an ingress port, the conformance rate of this port can be used for triggering flow control. In other words, once the tokens in Tc bucket is below  $8000_H$ , the start flow control can be generated on that port. When the tokens in Tc bucket is more than  $TCM\_EBS*64$ , the stop flow control can be generated on that port.

*Note: To achieve that functionality the assigned meter instance number must correspond to the respective ingress port. All ingress packets from the rate flow control enabled port must be green color.*

Conforming status for each port are readable via MTEBP bit in PCE\_TCM\_STAT register. Any change of conforming status can trigger the interrupt.

### 3.8.5.5 Rate Shaping

The Gigabit Ethernet Switch Macro supports 32 instances of rate shaper. Each rate shaper can be configured to Token Bucket mode or Credit Rate shaper mode. Each shaper mode can be configured via RSMOD bit in RS\_CTRL. Each shaper can measure the rate of an egress queue and prevent the queues which exceeded the configured rate from being scheduled for the next packet transmission. Shaping is based on a Committed Information Rate (CIR) and an associated Committed Burst Size (CBS). A queue can be selected for transmission only when it does not exceed the CBS for a given CIR.

Up to two shaping instances can be assigned to measure the egress rate of a specific queue or number of queues. Two shapers are typically being assigned to measure the peak and committed rate and typically have different CIR settings. Any number of queues can share the same shaping instance, in this case the committed rate and the burst size are shared among the assigned queues.

When there is no shaper assigned to a queue, the queue rate is not monitored. It is recommended to assign a shaper for queues with high scheduling weights or strict priority queues. See [Queue Scheduling](#) for details regarding queue scheduling.

### 3.8.5.6 Queue Scheduling

The scheduling function determines which queue is allowed to emit a packet. Queue scheduling is done after the rate shaping. The Gigabit Ethernet Switch Macro supports the following scheduling types for each one of the 32 egress QoS queues:

- **Weighted Fair Queueing (WFQ):** For a given port, packets in the WFQ queues are scheduled for transmission in accordance with their configured weight. The weight represents a ratio for transmission. The higher the weight of one queue compared to an other, the more often this queue is scheduled for transmission.
  - For example, a queue with weight 4000 is served twice more often than the queue with weight 2000.
- **Strict High Priority:** For a given port, packets in the strict high priority queue are scheduled for transmission before any packet in the WFQ queue. When there are multiple strict high priority queues configured for a port, the queues with a higher physical number are scheduled first.
- **Strict Low Priority:** For a given port, packets in the strict low priority queue are scheduled for transmission after any packet in the WFQ queue. When there are multiple strict low priority queues configured for a port, the queues with a higher physical number are scheduled first.

### 3.8.5.7 Congestion Management

The Gigabit Ethernet Switch Macro provides protection for the internal buffer from congestion and overflow.

When the shared buffer is fully occupied and does not have enough resources to receive any new frame, the incoming frames on all ports are discarded, until the congestion condition is relieved.

In addition, the Gigabit Ethernet Switch Macro provides two segment thresholds per color globally, per color per each egress port and per color per each egress queue. Based on the configured thresholds and the global, port or queue segment filling level a decision is made for every incoming packet, whether the packet with a given color can be enqueued or not. This protection mechanism is called Active Congestion Management (ACM).

The color of the packets is decided based on the conformance rate in the metering instance. See [Rate Metering](#) for details. The thresholds are checked with accordance to the incoming packet color: e.g., red thresholds for red colored packets, yellow for yellow and green for green.

The Gigabit Ethernet Switch Macro is able to reserve buffer per egress queue. This allows the protection of queues against congestion caused by other queues and ports. It provides a minimum buffer guarantee for each queue. A green frame can bypass ACM and is always accepted by the queue when the reserved buffer threshold of the queue is not exceeded.

The critical frames bypass the ACM and are enqueued regardless of the filling level. The critical frames are not enqueued only in case of buffer full event.

The ACM function discards the frames early (before the buffer full event) with certain drop probability. ACM thresholds provide the following functionality:

- **MIN Threshold.** When the filling level of the queue is below this threshold (excluding the threshold value), the packet with the appropriate color is not discarded and is enqueued.
- **MAX Threshold.** When the filling level of the queue is above this threshold (excluding the threshold value), the packet with the appropriate color is discarded.
- **$\frac{1}{2}(\text{MAX}-\text{MIN})$  Threshold.** when filling level of the queue is between the MIN and MAX thresholds, the packet is discarded with certain probability. The drop probability profile can be selected globally between 25%, 50% and 75%. When the filling level is below half the distance between MIN and MAX thresholds, the packet is discarded with lower probability ( $P_{\min}$ ), when the filling level is above half the distance between MIN and MAX thresholds, the packet is discarded with higher probability ( $P_{\max}$ ). Specifically, the following drop probability profiles can be selected globally:
  - P0:  $P_{\min} = 25\%$ ,  $P_{\max} = 75\%$  (default).
  - P1:  $P_{\min} = 25\%$ ,  $P_{\max} = 50\%$ .
  - P2:  $P_{\min} = 50\%$ ,  $P_{\max} = 50\%$ .
  - P3:  $P_{\min} = 50\%$ ,  $P_{\max} = 75\%$ .

*Note: When MIN = MAX, the drop probability changes from 0% to 100% at once.*

Figure 39 shows drop probability as a function of queue filling level and configured thresholds.

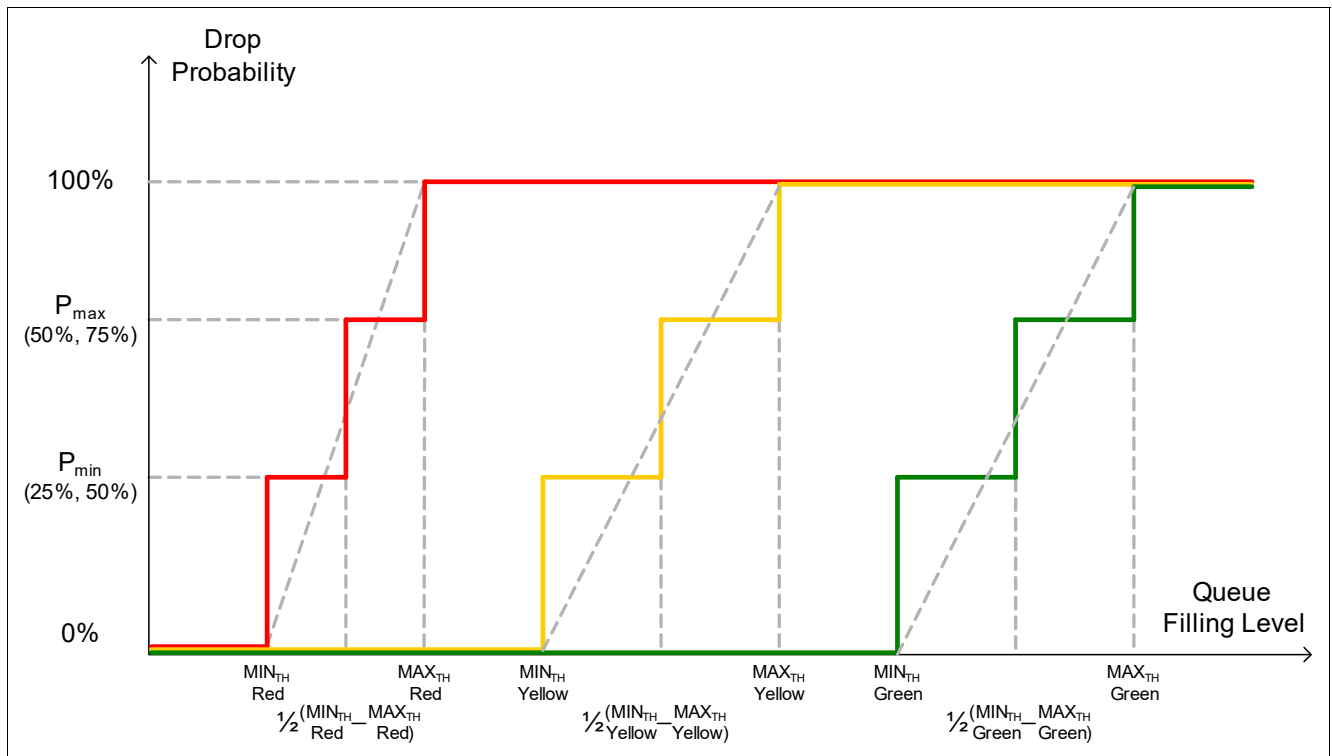

**Figure 39 Drop Precedence Thresholds**

*Note: The thresholds for red frames shown in the figure are below the threshold for yellow frames and the thresholds for yellow are below the thresholds for green frames. This is how it would be usually configured in a real application scenarios. The thresholds can be configured  $MIN_{TH}=MAX_{TH}$ , in this case the frames are dropped as soon as they pass the drop threshold.*

### 3.8.5.8 Ingress Port Congestion Based Flow Control

Flow control is activated when the ingress port local buffer congestion level exceeds a programmable local threshold (via SDMA\_PFCTHR9 of each port) and deactivated when the local buffer congestion level drops below a programmable local threshold (via SDMA\_PFCTHR8 of each port). The flow control applies to each port individually.

All ingress port congestion status are readable via SDMA\_CGNBP register. Any change of congestion status can trigger the interrupt.

### 3.8.5.9 Overview of the Resource Protection Mechanism

The Gigabit Ethernet Switch Macro provides several mechanism to protects its limited resources. The limited resources are:

- number of segments (total 512 segments)
- number of packet pointers (total 1024 pointers)

The limitation can be on different levels:

- Global Packet Pointers Usage
- Global Shared Segment Buffer Usage
- Ingress Port Shared Segment Buffer Usage
- Egress Port Shared Segment Buffer Usage
- Egress Queue Shared Segment Buffer Usage

The limiting mechanisms are:

- Flow Control
- Buffer Reservation
- Tail Drop
- WRED

#### Resource Protection

One method to protect the GSWIP from running out of resources is by issuing Flow Control. Several thresholds are provided.

There are three level flow control thresholds. When any one of the start flow control conditions below is met, start flow control is triggered on a port. When all the stop flow control conditions below are met, stop flow control is triggered on a port.

- Flow control based on global buffer filling level
- Flow control based on ingress port buffer filling level
- Flow control based on ingress port metering result.

Flow Control can be used together with the WRED thresholds. In this case, the Flow Control thresholds and the WRED thresholds must be coordinated. With WRED it is possible to configure a global color threshold, per port per color threshold or per queue per color threshold for red/yellow/green packets. When the max threshold is exceeded the frame is dropped. Filling levels between the min threshold and max threshold are dropped with a global configurable drop probability. Filling levels below the min threshold do not result in a drop. WRED can be used to avoid a situation where one queue uses up all the resources and affect the traffic on other queues. Typically a system is configured with a certain oversubscription which gives each queue enough resources to operate in a bursty environment but the situation that ports affect each other cannot be avoided.

When frame drops must be avoided the only possibility is to use Flow Control. Flow control threshold must be lower than the WRED and tail drop threshold.

Critical frames are accepted by WRED even when the thresholds are exceeded.

Green frames are accepted by WRED when the egress queue buffer usage is below the reserve buffer threshold.

**Table 36 Resource Protection Options**

| Level                                    | Mechanism             | Resource        | Number of Thresholds    | Granularity                   | Register (default values)   |
|--|-----------------------|-----------------|-------------------------|-------------------------------|---|
| Global Packet Pointer Usage              | Flow Control          | Packet pointers | 1 (THR7)                | Global                        | SDMA_FCTHR7(MAX)  |
|  | Tail Drop             | Packet pointers | 3 (one per color)       | Global per color              | BM_DROP_GTH_0 (MAX) red<br>BM_DROP_GTH_1 (MAX) yellow<br>BM_DROP_GTH_2 (MAX) green  |
| Global Shared Segment Buffer Usage       | Flow Control          | Segments        | 4 (THR1-4)              | Global                        | SDMA_FCTHR1 (0x82)<br>SDMA_FCTHR2 (0xAC)<br>SDMA_FCTHR3 (0xAC)<br>SDMA_FCTHR4 (0xAC)  |
|  | Tail Drop             | Segments        | 2 (THR5-6)              | Global                        | SDMA_FCTHR5 (MAX)<br>SDMA_FCTHR6 (MAX)  |
|  | WRED <sup>1) 2)</sup> | Segments        | 6 (two per color)       | Global per color              | BM_WRED_RTH_0 (MAX)<br>BM_WRED_RTH_1 (MAX)<br>BM_WRED_YTH_0 (MAX)<br>BM_WRED_YTH_1 (MAX)<br>BM_WRED_GTH_0 (MAX)<br>BM_WRED_GTH_1 (MAX)  |
| Ingress Port Shared Segment Buffer Usage | Flow Control          | Segments        | Two per port            | Per ingress port              | SDMA_PFCTH8 (MAX)<br>SDMA_PFCTH9 (MAX)  |
| Egress Port Shared Segment Buffer Usage  | WRED                  | Segments        | Two per port per color  | Per egress port and per color | BM_PWRED_RTH_0 (MAX)<br>BM_PWRED_RTH_1 (MAX)<br>BM_PWRED_YTH_0 (MAX)<br>BM_PWRED_YTH_1 (MAX)<br>BM_PWRED_GTH_0 (MAX)<br>BM_PWRED_GTH_1 (MAX)  |
| Queue                                    | Buffer Reservation    | Segments        | One per queue           | Per queue                     | PQM Context Table<br>• reservation threshold (0)  |
|  | WRED                  | Segments        | Two per queue per color | Per queue and per color       | PQM Context Table<br>• red max threshold (0x50)<br>• red min threshold (0x50)<br>• yellow max threshold (0x50)<br>• yellow min threshold (0x50)<br>• green max threshold (0x50)<br>• green min threshold (0x50) |

1) The drop probability can only be configured globally BM\_QUEUE\_GCTRL.DPROB (00 => Pmin = 25%, Pmax = 75%).

2) Tail Drop is realized by setting the min/max thresholds equal.

### ACM and Flow Control

ACM and Flow control can be configured individually. Typically the two features are used exclusively.

- ACM is used to avoid that a single queue can use up all the resources. When a limit is exceeded additional frames to this queue are dropped. Frame switching between other ports is still possible.
- Flow Control is used to avoid frame drops. Before the global resource is used up the peers are informed to stop frame transmission.
- With buffer reservation and suitable ACM WRED threshold, non-congested queues are protected and do not stopped by congested queues.

### 3.8.5.10 Storm Control

The Gigabit Ethernet Switch Macro supports a broadcast storm control function. Broadcast storm is defined as an excessive amount of broadcast, multicast, or unknown unicast Ethernet frames received on a switch port. Due to the massive replication of data frames, broadcast storm can significantly degrade the system performance. Broadcast storm can also be a form of Denial-of-Service (DoS) attack.

The storm control function can effectively police specific traffic type and protect the resources from being flooded by the broadcast traffic.

The selected metering instance is configured to the required policed rate of the broadcast storm. The following traffic types can be selected for the storm control function:

- Broadcast frames
- Unknown multicast frames
- Unknown unicast frames

When the rate of the selected frame types exceeds the rate configured in the meter instance, the frames marked as yellow or red. When the active congestion management thresholds configured appropriately, the storm frames are discarded.

### 3.8.6 Flow Classification Function

The Gigabit Ethernet Switch Macro includes a powerful packet classification engine that performs multi-field classification based on up to 64 programmable rules.

#### Traffic Flow Table

Traffic Flow table contains up to 64 programmable rules. Rules can be configured per ingress port but can also be shared between ports. Each rule consists of a pattern and action sections, as depicted in [Figure 40](#). A Pattern specifies certain combination of packet header fields. The Parser extracts the packet header fields from the received packet and provides them to the Traffic Flow table. When a pattern matches, the enabled actions apply. The pattern search continues until all actions are satisfied. This allows the definition of multiple pattern for different actions. Each action can be specifically enabled or disabled for a given pattern.

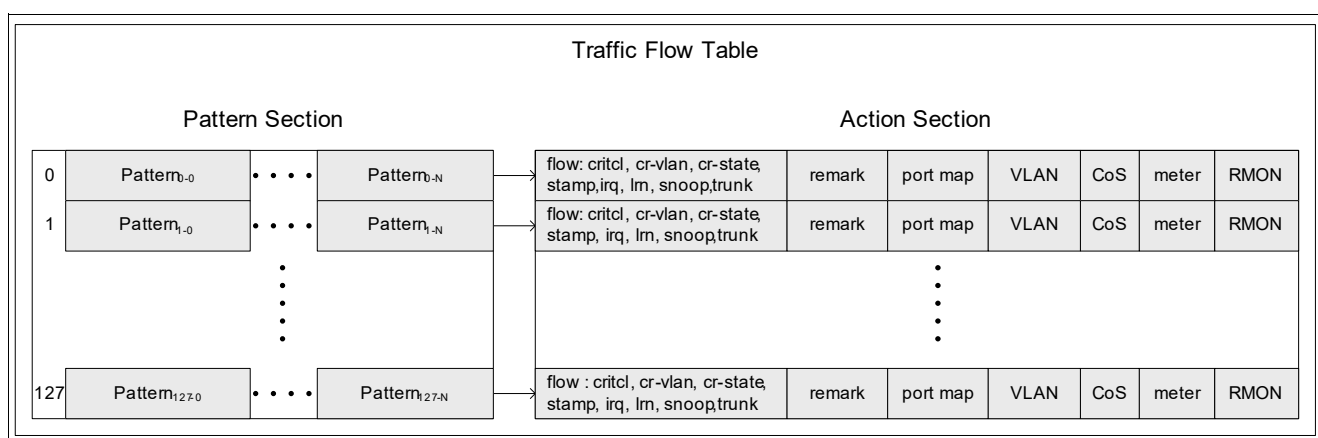

**Figure 40 Traffic Flow Table**

Rules location in the table defines their priority, rule entries with lower index number have higher priority. The Traffic Flow table is searched in a following way:

- **Pattern Match:** Pattern row is considered matched when all the fields in the pattern have been matched or configured to be ignored (not enabled). When a pattern row matches, the appropriate action row is checked for that pattern.

*Note: Multiple pattern rows in the table might match the search, however, only the first pattern in the table matched for certain action is applied.*

- **Action Match:** Each action in the action row can be enabled or disabled for certain pattern row match. When the action is enabled and the pattern row matched, this action is applied for the classified packet. The search in the table terminates only when all the actions in the action section have been found. When not, the search continues for the next pattern match and the corresponding action match. An additional option is to enable the action and to select a default behavior for that action, i.e., the search for another enabled action is terminated.

*Note: For a given packet classification only one pattern may match one specific action, however, multiple patterns may match multiple different actions, i.e., the action section is searched independently for each action type.*

See the following examples for clarification:

- First example: Consider two rules added to the table, one has a source MAC address in the pattern and a CoS assignment in the action section. Another rule (at different index) has an Ethertype in the pattern section and the action is a VLAN group association. When an incoming frame matches both patterns, both actions are applied for this frame.
- Second example: Consider a similar scenario as in the first example, whereas the only the action is VLAN group association for both pattern rows. In this case, only the rule with the lowest index is applied, i.e., similar action is executed with priority of the rule depending on the location in the table.



## Pattern Section

The pattern section contains the packet header fields and other parameters that can identify the incoming packet flow. Specifically, the following pattern fields are supported:

- Ingress port number. The parameter compared with the ingress port number of the incoming packet.
- Source MAC Address or part of the MAC Address specified by a programmable nibble mask<sup>1)</sup>.
- Destination MAC Address or part of the MAC Address specified by a programmable nibble mask<sup>1)</sup>.
- STAG VID or part of the STAG VID specified by a programmable nibble mask or a range.
- CTAG VID or part of the CTAG VID specified by a programmable nibble mask or a range.
- Ethernet type.
- IP Protocol and Parser Flags.
- PPPoE Session ID.
- IP Packet Length or length range.
- Source IP Address or part of the IP Address specified by a programmable nibble mask<sup>1)</sup>.
- Destination IP Address or part of the IP Address specified by a programmable nibble mask<sup>1)</sup>.
- CTAG PCP Code. This parameter is directly compared with the PCP code of the VLAN tag of the received frame. When the received frame contains no VLAN/Priority Tag, the parameter does not match.
- STAG PCP&DEI. This parameter is directly compared with the PCP&DEI of the VLAN tag of the received frame. When the received frame contains no VLAN/Priority Tag, the parameter does not match.
- DSCP Code. This parameter compared directly with the DSCP code in the IP header. When the received packet contains no IP header, the parameter does not match.
- The first 4 bytes of the packet content following the IP header or first 4 bytes of packet content following the Ethertype for non IP and non PPPoE packets or first 4 bytes of packet content following the PPPoE header for non IP and PPPoE packets. For TCP/UDP the 4 bytes following the IP header are the TCP/UDP source and destination ports. Any part of this content can be masked-out by a programmable nibble mask<sup>1)</sup>.

Each field in the pattern section is enabled or disabled for the search. When the parameter is disabled, the corresponding pattern is not compared. The pattern is considered to be matched by default for any value of the corresponding packet field.

*Note: When an IP packet is carried in a PPPoE frame, the Ethertype is 0x8864 but there is no explicit Parser Flag for IP\_indication and no PPP\_protocol field that shows that the PPPoE carried IP. A rule mat want to forward all IPoPPPoE to a specific port. When there would be a PPP\_protocol field this rule could be defined by the a match on Ethertype=0x8864 AND PPP\_protocol=0x0021. Since there is no PPP\_protocol field such a rule can be defined by configuring an "always match" entry in the IP address table (an entry with all masks active). When there is an IP in the PPPoE frame, the "always match" entry matches, when there is no IP in the PPPoE frame, the IP address table is not searched and the result is a "no\_match" indication. With this match indications and the Ethertype=0x8864, the IP\_indication flag and PPP\_protocol field are not required.*

## Actions Section

The action section contains the actions applicable to an incoming packet. Specifically, the following are supported:

- **Port Bitmap (used as Port Map/Port Member/Flow\_ID):** The received packet (packet flow) can be redirected to a single or multiple egress ports based on a pattern match. Redirection includes the packet discard option when the packet is redirected to the NULL port (all zero port map). Based on the port bitmap multiplexing control in the action, this field is also used as STAG port member which identifies the broadcast domain. The broadcast domain of the received packet is restricted according to the this field on top of the other filtering function. When the Flow\_ID action is configured, the field holds the Flow\_ID instead of the port map or port member. The Flow\_ID can be written into the egress special tag.
- **Traffic Class Assignment (CoS):** Traffic class of the received packet can be assigned or changed from a default assignment based on the pattern match.

1) Note: mask resolution is nibble, i.e., every 4 bits can be masked out.

- **VLAN Assignment:** VLAN classification of the received packet can be assigned or changed from a default assignment based on the pattern match. Both service VLAN tag and customer VLAN tag are supported.
- **Metering Assignment:** A Metering instance can be assigned or changed from a default assignment based on the pattern match.
- **RMON Assignment:** Dedicated packet counters can be assigned to a specific flow. The counters are incremented each time the pattern is matched.
- **Flow Actions:** The following additional flow actions can be assigned only in the flow table (by default these actions are disabled):
  - Cross VLAN packet indication. Certain packet can be identified as cross VLAN. VLAN filtering rules are ignored for these packets, e.g, cross VLAN packets may cross VLAN boundaries.
  - Cross state packet indication. Certain packet can be configured to ignore the port state of the ingress or egress port. These packets are forwarded even when all the “regular” frames are discarded.
  - Critical packet indication. Packets identified as critical bypass active congestion management function (ACM) and are enqueued to a certain queue regardless of the filling level of that queue.
  - Time stamping. Ingress/egress time stamp can be recorded for packets identified by matched pattern. The time stamps are sampled during packet reception/transmission and can be retrieved by the management action.
  - Interrupt request assertion. An external interrupt can be asserted based on a pattern match.
  - Learning action. Learning function can be forced to be enabled or disabled.
  - Snooping action. A specific IGMP snooping action can be selected for the IGMP messages. Note, relevant only for the IGMP hardware based snooping.
  - Flow\_ID action. A Flow indication can be configured and written into the egress Special Tag. See [Special Tag Functionality](#) for more details.
  - Forwarding Multiplexing Control. These control signals select the appropriate Port-Map in Forwarding Classification.
  - Port Bitmap Multiplexing Control. This control signal select the port bitmap mode: used as STAG Port-Map or Port-Member in Forwarding Classification.
  - Trunking Link Selection. The destination trunking link can be assigned or changed from a default assignment based on the pattern match.

Each single action in the action section can be enabled or disabled for the search. When an action is disabled, the table search continues until another pattern matches for this action. When no other pattern matches, the corresponding action is not applied.

### 3.8.7 Operation, Administration, and Management Functions

This section summarizes the functions provided to control and monitor the data traffic through the switch.

#### 3.8.7.1 Monitoring Counters

Multiple counters are provided per port to monitor incoming and outgoing data traffic as well as errors or special events. Each port provides the same set of counters. There are two main groups of counters, which are a set of standard Ethernet counters (also known as RMON counters) and a group of counters assigned to programmable traffic flows. See the following sections for details.

##### Standard (RMON) Counters

The Gigabit Ethernet Switch Macro supports 34 standard frame counters of 32-bit each and 3 byte counters of 64-bit each. The counters are not cleared on read, instead complete set of port counters can be cleared by the appropriate management action. It can be configured when the 8 byte special tag is excluded from the byte counters. [Table 37](#) lists the standard RMON counters.

**Table 37 Standard RMON Counters**

| Short Name              | Long Name   | Description  |
|-------------------------|---|--|
| <b>Receive Counters</b> |   |  |
| nRxUnicastPkts          | Received Unicast Ethernet frames                            | Counts the total number of valid <sup>1)</sup> Unicast Ethernet frames received on the ingress port.   |
| nRxTotalPkts            | Received Total Ethernet frames or Broadcast Ethernet frames | Counts the total number of valid <sup>1)</sup> Ethernet frames or total number of valid Broadcast Ethernet frames received on the ingress port. The mode is configurable via BCAST_CNT bit in BM_RMON_CTRL |
| nRxMulticastPkts        | Received Multicast Ethernet frames                          | Counts the total number of valid <sup>1)</sup> Multicast Ethernet frames (not including Broadcast frames) received on the ingress port.  |
| nRxFCS_ErrorPkts        | Received CRC errors   | Counts the total number of Ethernet frames that have been received with an FCS error.  |
| nRxUnderSizeGoodPkts    | Received good undersized Ethernet frames                    | Counts the total number of Ethernet frames received with Undersize Error but with correct FCS.   |
| nRxUnderSizeErrorPkts   | Received bad undersized Ethernet frames                     | Counts the total number of Ethernet frames received with Undersize Error and bad FCS.  |
| nRxOversizeGoodPkts     | Received good oversized Ethernet frames                     | Counts the total number of Ethernet frames received with Oversize Error but with correct FCS.  |
| nRxOversizeErrorPkts    | Received bad oversized Ethernet frames                      | Counts the total number of Ethernet frames received with Oversize Error and bad FCS.   |

**Table 37 Standard RMON Counters (cont'd)**

| Short Name        | Long Name                                 | Description  |
|-------------------|---|--|
| nRxGoodPausePkts  | Received good Pause Ethernet frames       | Counts the total number of received valid <sup>1)</sup> Ethernet Pause frames.   |
| nRxAlignErrorPkts | Received alignment errors                 | Counts the total number of packets received with a <ul style="list-style-type: none"> <li>• alignment error or</li> <li>• length errors or</li> <li>• phy_rx errors or</li> <li>• all errors of above</li> </ul> The error which must be counted can be configured globally. Error ignore flags are not considered (counting is done) only in the "all" case.<br>An alignment error is specified as a non-integral number of octets. |
| nRx64BytePkts     | Received frame size 64 byte               | Counts the total number of valid <sup>1)</sup> Ethernet frames received with the minimum valid length of 64 byte.  |
| nRx127BytePkts    | Received frame size 65-127 byte           | Counts the total number of valid <sup>1)</sup> Ethernet frames received with a length in the range of 65 to 127 byte.  |
| nRx255BytePkts    | Received frame size 128-255 byte          | Counts the total number of valid <sup>1)</sup> Ethernet frames received with a length in the range of 128 to 255 byte.   |
| nRx511BytePkts    | Received frame size 256-511 byte          | Counts the total number of valid <sup>1)</sup> Ethernet frames received with a length in the range of 256 to 511 byte.   |
| nRx1023BytePkts   | Received frame size 512-1023 byte         | Counts the total number of valid <sup>1)</sup> Ethernet frames received with a length in the range of 512 to 1023 byte.  |
| nRxMaxBytePkts    | Received frame size larger than 1023 byte | Counts the total number of valid <sup>1)</sup> Ethernet frames received with a length of 1024 byte or more.<br><i>Note: When Jumbo frames are enabled on the related port, these frames are also included in this counter.</i>   |
| nRxDroppedPkts    | Receive dropped Ethernet frames           | Counts the total number of frames discarded due to the lack of shared resources, i.e., in case of complete buffer congestion.  |
| nRxFilteredPkts   | Received filtered Ethernet frames         | Counts the total number of Ethernet frames discarded due to a violation detected by the Classification Engine, i.e., frame filtering based on matched multi-field classification rule.   |
| nRxGoodBytes      | Received good bytes                       | Total number of bytes received in valid <sup>1)</sup> Ethernet frames. This is a 64-bit counter  |

**Table 37 Standard RMON Counters (cont'd)**

| Short Name               | Long Name  | Description   |
|--------------------------|--|---|
| nRxBadBytes              | Received bad bytes   | Total number of bytes received in invalid Ethernet frames. This is a 64-bit counter   |
| <b>Transmit Counters</b> |  |   |
| nTxACMDiscardPkts        | Transmit Queue ACM Discard frames                              | Counts the total number of packets discarded by the ACM mechanism (Active Congestion Management) due to exceeded thresholds on the egress QoS queues.   |
| nTxUnicastPkts           | Transmitted Unicast Ethernet frames                            | Counts the total number of Unicast Ethernet frames transmitted on the egress port.  |
| nTxTotalPkts             | Transmitted Total Ethernet frames or Broadcast Ethernet frames | Counts the total number of total frames or Broadcast frames transmitted on the egress port. The mode is configurable via BCAST_CNT bit in BM_RMON_CTRL.   |
| nTxMulticastPkts         | Transmitted Multicast Ethernet frames                          | Counts the total number of Multicast Ethernet frames (not including Broadcast frames) transmitted on the egress port.   |
| nTx64BytePkts            | Transmitted frame size 64 byte                                 | Counts the total number of Ethernet frames transmitted with the minimum valid length of 64 byte.  |
| nTx127BytePkts           | Transmitted frame size 65-127 byte                             | Counts the total number of Ethernet frames transmitted with a length in the range of 65 to 127 byte.  |
| nTx255BytePkts           | Transmitted frame size 128-255 byte                            | Counts the total number of Ethernet frames transmitted with a length in the range of 128 to 255 byte.   |
| nTx511BytePkts           | Transmitted frame size 256-511 byte                            | Counts the total number of Ethernet frames transmitted with a length in the range of 256 to 511 byte.   |
| nTx1023BytePkts          | Transmitted frame size 512-1023 byte                           | Counts the total number of Ethernet frames transmitted with a length in the range of 512 to 1023 byte.  |
| nTxMaxBytePkts           | Transmitted frame size larger than 1023 byte                   | Counts the total number of Ethernet frames transmitted with a length of 1024 byte or more.<br><br><i>Note: When Jumbo frames are enabled on the related port, these frames are also included in this counter.</i> |
| nTxCollCount             | Transmitted total collision number                             | Counts the total number of Ethernet frames transmitted on the egress port after any "Collision" event.  |
| nTxSingleCollCount       | Transmitted single collisions                                  | Counts the total number of Ethernet frames transmitted on the egress port after a "Single Collision" event.   |

**Table 37 Standard RMON Counters (cont'd)**

| Short Name         | Long Name                        | Description   |
|--------------------|----------------------------------|---|
| nTxMultCollCount   | Transmitted multiple collisions  | Counts the total number of Ethernet frames transmitted on the egress port after a "Multiple Collision" event.   |
| nTxLateCollCount   | Transmitted late collisions      | Counts the total number of Ethernet frames transmitted on the egress port after a "Late Collision" event.       |
| nTxExcessCollCount | Transmitted excessive collisions | Counts the total number of Ethernet frames transmitted on the egress port after an "Excessive Collision" event. |
| nTxPauseCount      | Transmitted Pause frames         | Counts the total number of "Pause" frames transmitted on the egress port.                                       |
| nTxDroppedPkts     | Transmit dropped frames          | Counts the total number of packets discarded due to port disable, excess collision or late collision.           |
| nTxGoodBytes       | Transmitted good bytes           | Total number of bytes transmitted in Ethernet frames. This is a 64-bit counter.                                 |

1) Every packet received without any reception error is considered to be valid. This includes Unicast, Multicast and Broadcast packets.

### Traffic Flow Counters

There is a set of 24 packet-based counters available per port, where each can be assigned to a dedicated traffic flow, as specified in the Traffic Flow table. Each traffic flow is defined by an entry in the traffic flow table, counters are connected with a traffic flow in a flexible way. The counter number is entered as one of the table actions. See [Flow Classification Function](#) for details.

### 3.8.7.2 Port Mirroring

The Gigabit Ethernet Switch Macro supports port monitoring to assist in system debugging or enable a software-controlled functionality. The data received on a selected port may be mirrored to another selected port (the monitoring port).

#### Mirroring Function

Mirroring means the received frame is processed and forwarded as normal, but a copy of that frame is in addition sent to the monitoring port. The options given by the port mirroring function are:

- Copy data received on a selected port to the monitoring port.
- Copy data received on a selected group of ports to the monitoring port.
- Copy data transmitted on a selected port to the monitoring port.
- Copy data transmitted on a selected group of ports to the monitoring port.
- Copy data received or transmitted on a selected port to the monitoring port.
- Copy data received or transmitted on a selected group of ports to the monitoring port.

Figure 41 and Figure 42 provide illustrations on the ingress and egress monitoring.

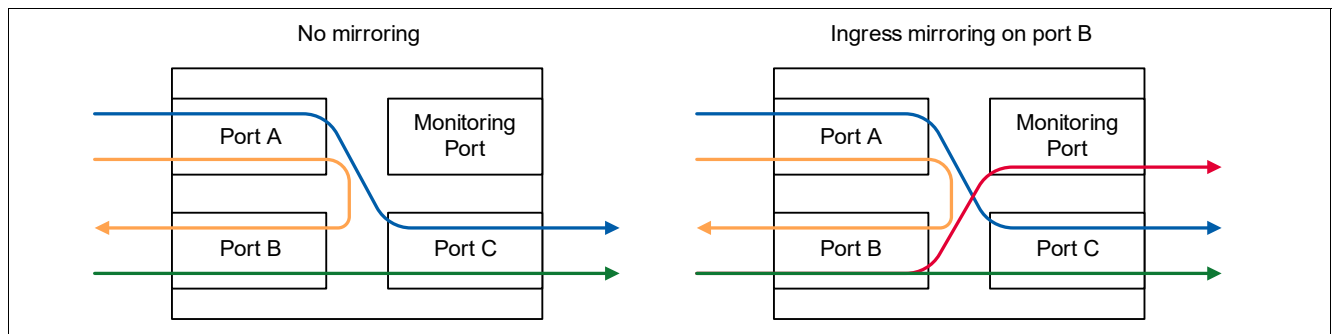

Figure 41 Port Mirroring Examples – Ingress Monitoring

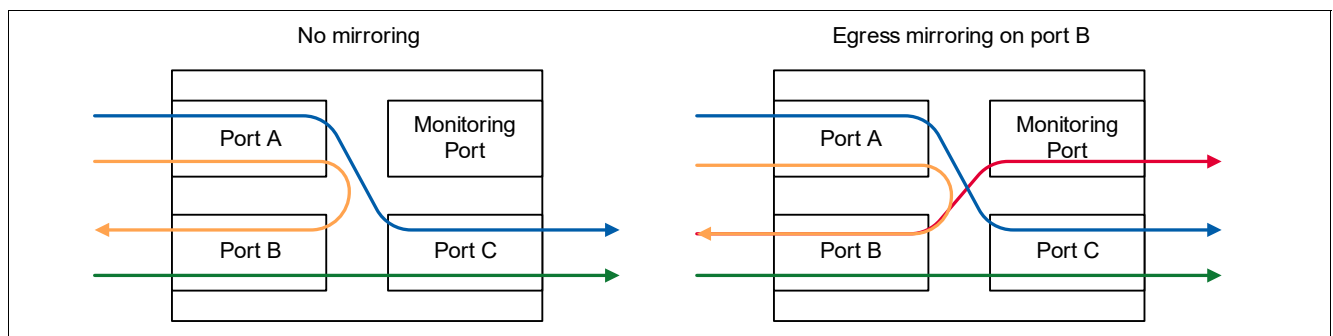

Figure 42 Port Mirroring Examples – Egress Monitoring

Mirroring can also be used to create diagnostic loopbacks, when the ingress port is identical to the monitoring port.

#### Error Monitoring

The mirroring function is used to monitor frames otherwise dropped due to reception errors, packet filtering, or violation of certain classification rules. In this case, the received frame is only delivered to the monitoring port and not to the target egress port defined in the egress port map.

Error monitoring can be explicitly enabled for the following type of violations:

- Frame dropped by the classification engine (the destination port map is all-zero)
- Frame contains L2 reception errors
- Frame contains an unknown VLAN ID (the frame carries a VLAN ID that has not been defined in the active VLAN table)

- VLAN Ingress rule violation (acceptable frame filter, i.e. “admit all tagged”)
- Ingress or egress VLAN membership violation (the frame carries a known VLAN ID, but the port is not member of the VLAN group)
- Port state violation
- MAC learning limit violation (the maximum number of MAC addresses to be learned for the port has been exceeded)
- MAC port lock or spoofing detection violation (the MAC source address has already been learned on another port)

### 3.8.7.3 Wake-on-LAN Functionality

Wake-on-LAN functionality (WoL) is used to wake up a network device by sending a dedicated Layer-2/Layer-3 data packet. The Gigabit Ethernet Switch Macro detects such packets on its Ethernet input ports and triggers an interrupt. This interrupt can be used to wake up an external device, such as a router connected to the switch. Particularly, the following functions are provided:

- Detects “magic packets”
  - Addressed to a dedicated unicast MAC destination address
  - Addressed to a known multicast destination address
  - Addressed to the broadcast MAC destination address
- Password protection can be enabled for magic packets
- Programmable target MAC address
- WoL Interrupt
- WoL packet receive port indication
- WoL enable/disable per port
- Magic packets are forwarded as any other packets (for example based on the MAC destination address) but may as well be dropped when the frame classification is set up accordingly.

In addition to these standard WoL functions, a wake-up can be triggered by making an entry in the Flow Engine and programming a corresponding action to generate an interrupt. This allows to wake up for any frame pattern. Typical patterns are:

- a specified MAC destination address
- a specified MAC source address
- ARP request packets
- directed IPv4/IPv6 packets

**Figure 43** shows the typical Layer-2 magic packets structure. However the fixed pattern followed by the specific unicast address and an optional password can appear in any field location in a packet, including Layer-3 part.

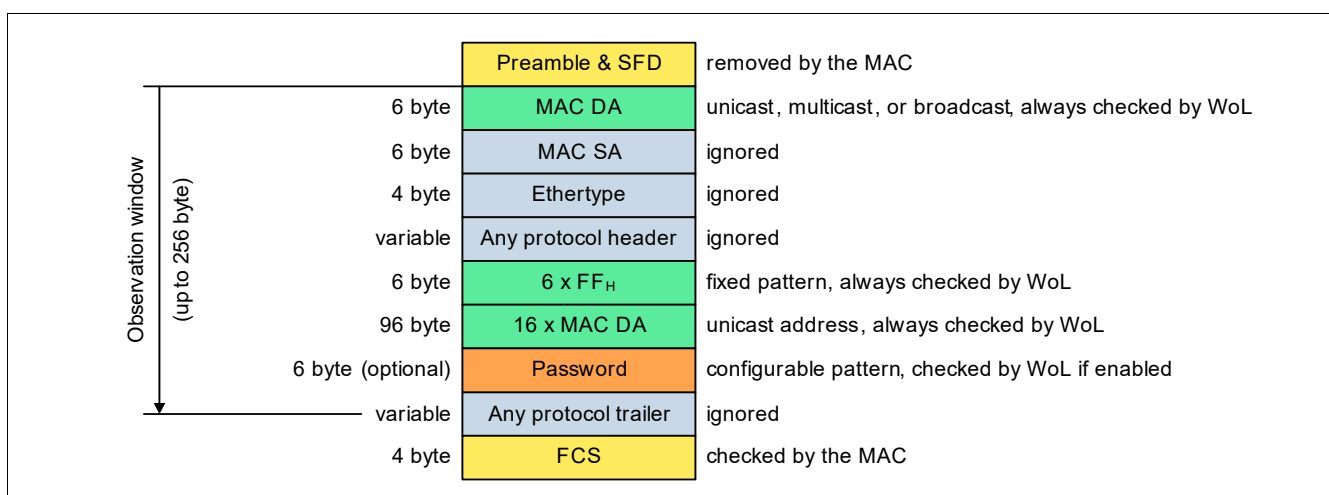

**Figure 43 Typical Magic Packet Data Structure**



The WoL sequence starts with a synchronization pattern of  $6 \times FF$ , followed by 16 repetitions of the target system's MAC address. This must be the unicast address, while the MAC destination address in the layer-2 header may be either the unicast address, the broadcast address, or a multicast address of a group that contains the target system's address. After the WoL pattern, any protocol-specific trailer may follow and the frame must be terminated by a valid frame checksum (FCS). The frame size must be less or equal to the maximum allowed frame size.

As an option, a password can be defined and checked for the received WoL frames. When the password does not match the configured value, the frame is ignored. The password has the same size as the MAC address (6 byte).

**Figure 44** shows the frame structure of a typical Layer-2 password-protected WoL frames.

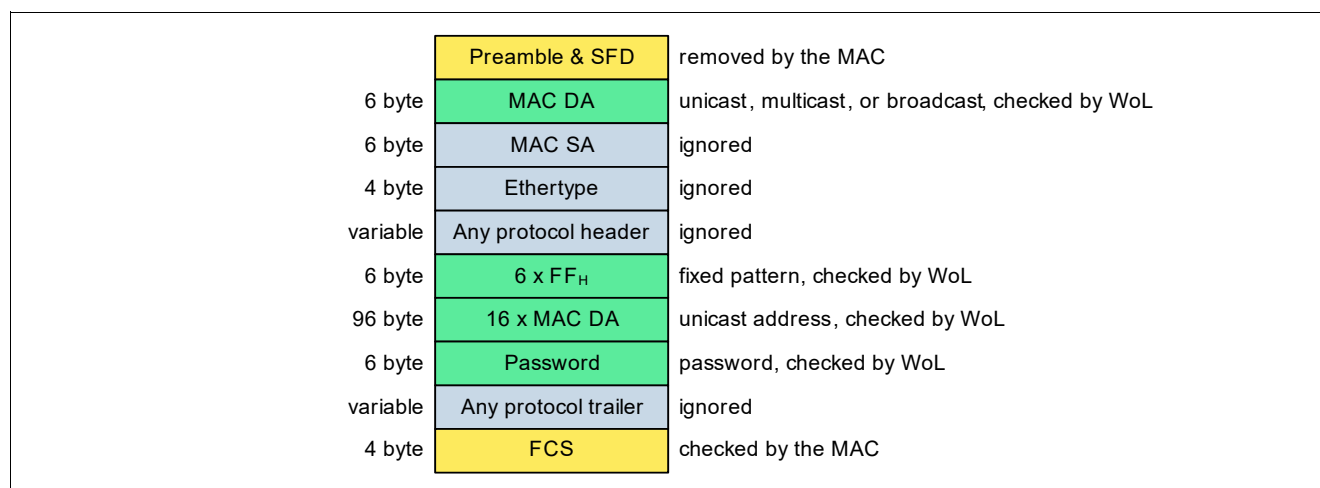
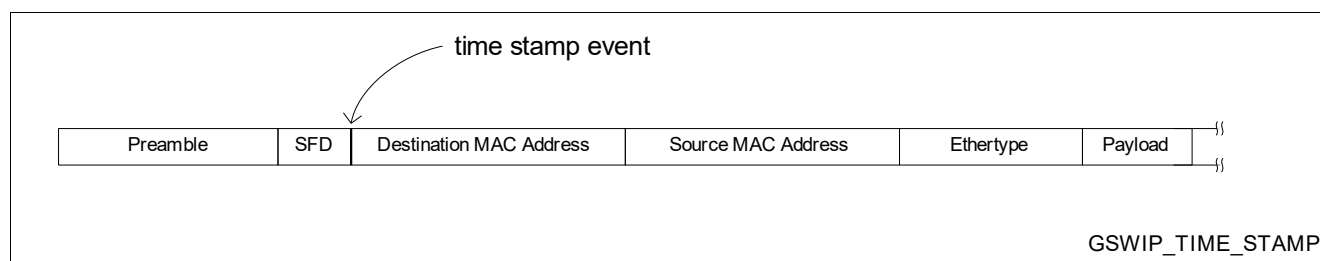

**Figure 44 Magic Packet Data Structure – Password Protection**

### 3.8.7.4 Time Stamp Functionality

A 94-bit global timer is implemented. It has three parts: a 32-bit second field, a 30-bit nano-second field and a 32-bit fractional-nano-second field. The global timer can be modified directly, adjusted with a positive/negative value or adjusted with a frequency offset via the following registers: `TIMER_FS_LSB`, `TIMER_FS_MSB`, `TIMER_NS_LSB`, `TIMER_NS_MSB`, `TIMER_SEC_LSB`, `TIMER_SEC_MSB` and `TIMER_CTRL`.

The Gigabit Ethernet Switch Macro can record a time stamp during frame reception and transmission to support IEEE 1588v2. The time stamp is recorded in hardware at the moment of reception (on ingress) or transmission (on egress) of the first byte of destination MAC address on the attached interface, as described in the **Figure 45**.



**Figure 45 Time Stamp Event Location in the Frame**

To have the time stamp recorded for a specific frame type, an appropriate rule must be added to the Traffic Flow table and a time stamp action selected for ingress time stamp, egress or both. In addition, an interrupt can be generated at the event of the time stamp record. The current timestamp value (2 least significant bit of second field and 30-bit nano-second field) is stored in a register, per port one register for the ingress arrival time (`SDMA_TSTAMP0` and `SDMA_TSTAMP1`) and for the egress departure time (`FDMA_TSTAMP0` and `FDMA_TSTAMP1`) is provided. The time stamp can be retrieved by an appropriate management action.

### 3.8.7.5 Special Tag Functionality

The special tag is used to override the forwarding and QoS functionality of the switch on the ingress side and to provide additional frame-status information on the egress side.

The special tag is identified by the special Ethertype located after the source MAC address in the frame. This allows the transmission of the frame via an Ethernet network to a remote receiver. The special tag content has a fixed length of 6 bytes. For internal communication or point-to-point communication it can be configured per egress port when the frame contains additional content in place of the Ethertype. This option is only available at egress direction, in ingress direction always an Ethertype is expected. See [Figure 46](#).

The pause frames generated by the MAC do not contain a special tag. This may result in a mix of frames with and without special tag on one egress port. Frames with a special tag which do not use the special Ethertype can be distinguished from pause frames since the pause frames have an Ethertype of 0x8808 while the first nibble after the MAC addresses is 0 for frames with a special tag.

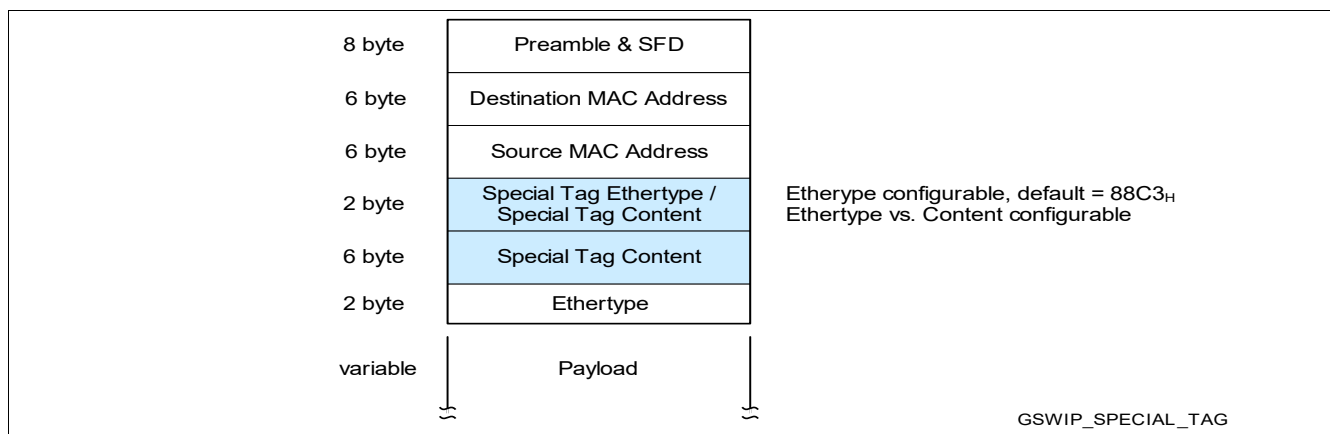

**Figure 46 Special Tag Location in the Frame**

*Note: The special tag is used on the CPU port of the switch.*

The content format of the special tag is different for the ingress and the egress, the egress special tag comes in two formats (internal and external format). The following sections describe the different formats of the tag.

#### Ingress Special Tag

The ingress special tag is used to override the classification function and the default frame forwarding of the switch. The special tag detection on ingress is enabled or disabled per port. When the detection is disabled, the frame containing a special tag is treated as regular frame and the content of the frame is ignored.

When the ingress special tag detection is enabled, the content of the tag is used for the frame forwarding decision. The ingress special tag must always have a special tag Ethertype. See [Table 38](#) for details.

**Table 38 Special Tag Ingress Format**

| Byte | Bit   | Description   |
|------|-------|---|
| 0    | [7:0] | <b>Ethertype byte 1</b> (configurable, default: 88 <sub>H</sub> )                           |
| 1    | [7:0] | <b>Ethertype byte 2</b> (configurable, default: C3 <sub>H</sub> )                           |
| 2    | 7     | <b>Port map enable</b> (1 <sub>B</sub> = use port map, 0 <sub>B</sub> = use port mask)      |
|      | 6     | <b>Traffic class enable</b> (1 <sub>B</sub> = use traffic class, 0 <sub>B</sub> = ignore)   |
|      | 5     | <b>Time stamp enable</b> (1 <sub>B</sub> = generate time stamps, 0 <sub>B</sub> = ignore)   |
|      | 4     | <b>Force no learning</b> (1 <sub>B</sub> = address is not learned, 0 <sub>B</sub> = ignore) |
|      | [3:0] | <b>Target traffic class</b> (egress priority)   |

**Table 38 Special Tag Ingress Format (cont'd)**

| Byte | Bit   | Description   |
|------|-------|---|
| 3    | [7:0] | <b>Target egress port map</b> (low bits)  |
| 4    | [7:0] | <b>Target egress port map</b> (Reserved)  |
| 5    | [7:5] | <b>Reserved</b> (all zero)  |
|      | 4     | <b>Interrupt enable</b> (1 <sub>B</sub> = generate an interrupt, 0 <sub>B</sub> = ignore) |
|      | [3:0] | <b>Source Port</b> (virtual port)   |
| 6    | [7:0] | <b>Reserved</b> (all zero)  |
| 7    | [7:0] | <b>Reserved</b> (all zero)  |

Note: Bytes are defined as MSB = bit 7 and LSB = bit 0.

**Table 39** and **Table 40** describes the encoding of the port map enable and traffic class enable fields of the special tag content.

**Table 39 Port Map Coding**

| Port Map Enable | Resulting Port Map  |
|-----------------|---|
| 0               | The egress port map is based on the forwarding classification result. The port map in the special tag is used as a filter (AND mask) on the final egress port map in the forwarding function => when a bit in the special tag port map is not set for certain egress port this port is excluded from the final egress port map. |
| 1               | The port map determined by forwarding classification result in switch is overruled. The port map in the special tag is used as the egress port map.   |

**Table 40 Traffic Class Map Coding**

| Traffic Class Enable | Resulting Traffic Class   |
|----------------------|---|
| 0                    | The traffic class is based on the classification result in switch.                  |
| 1                    | The traffic class is taken from the special tag (classified traffic class ignored). |

Additional action flags in the ingress special tag:

- **Time-stamp Action.** This action flag triggers the latching of the time-stamps for the received packet.
- **Interrupt Action.** This action generates an interrupt upon the packet reception.
- **Force No Learning.** This action disables the learning of the source MAC address of the received frame in the MAC bridging table.

The special tag detected on the ingress side is not delivered to the egress side. The tag is removed prior to transmission.

### Egress Special Tag

The egress special tag contains status and debug information of the switch. The special tag transmission on egress is enabled or disabled per egress port. When egress special tag is disabled, no special tag is inserted in the egress frame. When egress special tag function is enabled, each egress frame transmitted on that port contains the special tag.

The egress special tag is transmitted in one of the two formats:

- **External format.** This format contains Ethertype (2 bytes) and content (6 bytes).
- **Internal format.** This format contains no Ethertype and only content (8 bytes).

The external format can be used to transport the special tag via a network, the internal format is used for directly attached devices like a CPU which know how handle the special frame format. See [Table 41](#) and [Table 42](#) for details.

*Note: Bytes are defined as MSB = bit 7 and LSB = bit 0.*

**Table 41 Special Tag Egress External Format (with Ethertype)**

| Byte | Bit   | Description  |
|------|-------|--|
| 0    | [7:0] | <b>Ethertype</b> byte 1 (configurable, default: 88 <sub>H</sub> )  |
| 1    | [7:0] | <b>Ethertype</b> byte 2 (configurable, default: C3 <sub>H</sub> )  |
| 2    | [7:4] | <b>Traffic Class</b><br>The traffic class of the packet determined by the switch classification engine.  |
|      | [3:0] | <b>Ingress port number</b> (000 <sub>B</sub> = port 0, ..., 110 <sub>B</sub> = port 6, ...)  |
| 3    | 7     | <b>PPPoE Session Packet</b><br>0 <sub>B</sub> The packet is not PPPoE session packet<br>1 <sub>B</sub> The packet is PPPoE session packet  |
|      | 6     | <b>IPv4 Packet</b><br>0 <sub>B</sub> The packet is IPv6 packet when IP offset != 0<br>1 <sub>B</sub> The packet is IPv4 packet when IP offset != 0   |
|      | [5:0] | <b>IP Offset<sup>1)</sup></b> .<br>It defines the byte offset of the first byte in IP field relative to the first byte of destination MAC address of the egress packet                                       |
| 4    | [7:0] | <b>Destination Logical Port Map (low bits)</b>   |
| 5    | [7:0] | <b>Destination Logical Port Map (Reserved)</b>   |
| 6    | 7     | <b>Mirror indication</b> , signals when the frame has been mirrored.<br>0 <sub>B</sub> <b>NORM</b> normal frame<br>1 <sub>B</sub> <b>MIRR</b> mirrored frame   |
|      | 6     | <b>Known L2 unicast/multicast</b><br>0 <sub>B</sub> The packet destination MAC does not match one entry in bridging table.<br>0 <sub>B</sub> The packet destination MAC matches one entry in bridging table. |
|      | [5:0] | <b>Packet Length High Bits<sup>1)</sup></b><br>The total number of bytes in the egress packet.   |
| 7    | [7:0] | <b>Packet Length Low Bits<sup>1)</sup></b><br>The total number of bytes in the egress packet.  |

1) When a packet is modified at the egress side (packet header modification) with new bytes inserted or removed, the Is Tagged Flag, IP Offset and Packet Length fields are updated accordingly and contain the adjusted value for the transmitted frame. The IP\_Offset and the Packet\_Length includes the length of the special tag.

**Table 42 Special Tag Egress Internal Format (without Ethertype)**

| Byte | Bit   | Description  |
|------|---|--|
| 0    | [7:4]   | <b>Reserved</b> (all zero).<br>Serves also as code to distinguish pause frames generated by the MAC from frames with special tag without Ethertype since pause frames start with “8” and not 0.  |
|      | 3   | <b>Receive error</b> indication (MAC error)<br>0 <sub>B</sub> <b>OK</b> Frame is Ok<br>1 <sub>B</sub> <b>ERR</b> Frame contains a MAC error  |
|      | 2   | <b>Drop indication</b> , signals when a mirrored packet has been dropped (delivered only to the mirror port) or has been forwarded (delivered normally and to the mirror port)<br>0 <sub>B</sub> <b>FWD</b> frame has been forwarded<br>1 <sub>B</sub> <b>DROP</b> frame has been dropped        |
|      | [1:0]   | <b>Drop precedence</b> , defines when the frame must be eligible for dropping.<br>00 <sub>B</sub> <b>CRT</b> Critical frame indication<br>01 <sub>B</sub> <b>GRN</b> drop precedence low<br>10 <sub>B</sub> <b>YEL</b> drop precedence medium<br>11 <sub>B</sub> <b>RED</b> drop precedence high |
| 1    | [7:0] <b>Flow/Error Indication</b> <ul style="list-style-type: none"> <li>• <b>Flow Indication</b> (when Receive error = OK and drop Indication = FWD)</li> <li>• <b>Error Indication</b> <ul style="list-style-type: none"> <li>– errored frames (when Receive error = ERR)</li> <li>– dropped frames (when Receive error = OK and drop Indication = DROP)</li> </ul> </li> </ul> The error code for discarded or errored frames are described in <a href="#">Table 43</a> |  |
| 2    | [7:4]   | <b>Traffic Class</b><br>The traffic class of the packet determined by the switch classification engine.  |
|      | [3:0]   | <b>Ingress port number</b> (000 <sub>B</sub> = port 0, ..., 110 <sub>B</sub> = port 6, ...)  |
| 3    | 7   | <b>PPPoE Session Packet</b><br>0 <sub>B</sub> The packet is not PPPoE session packet<br>1 <sub>B</sub> The packet is PPPoE session packet  |
|      | 6   | <b>IPv4 Packet</b><br>0 <sub>B</sub> The packet is IPv6 packet when IP offset != 0<br>1 <sub>B</sub> The packet is IPv4 packet when IP offset != 0   |
|      | [5:0]   | <b>IP Offset<sup>1)</sup></b> .<br>It defines the byte offset of the first byte in IP field relative to the first byte of destination MAC address of the egress packet   |
| 4    | [7:0]   | <b>Destination Logical Port Map (low bits)</b>   |
| 5    | [7:0]   | <b>Destination Logical Port Map (Reserved)</b>   |

**Table 42 Special Tag Egress Internal Format (without Ethertype) (cont'd)**

| Byte | Bit   | Description  |
|------|-------|--|
| 6    | 7     | <b>Mirror indication</b> , signals when the frame has been mirrored.<br>0 <sub>B</sub> <b>NORM</b> normal frame<br>1 <sub>B</sub> <b>MIRR</b> mirrored frame   |
|      | 6     | <b>Known L2 unicast/multicast</b><br>0 <sub>B</sub> The packet destination MAC does not match one entry in bridging table.<br>0 <sub>B</sub> The packet destination MAC matches one entry in bridging table. |
|      | [5:0] | <b>Packet Length High Bits<sup>1)</sup></b><br>The total number of bytes in the egress packet.   |
| 7    | [7:0] | <b>Packet Length Low Bits<sup>1)</sup></b><br>The total number of bytes in the egress packet.  |

1) When a packet is modified at the egress side (packet header modification) with new bytes inserted or removed, the Is Tagged Flag, IP Offset and Packet Length fields are updated accordingly and contain the adjusted value for the transmitted frame. The IP\_Offset and the Packet\_Length includes the length of the special tag.

**Table 43 Error Codes**

| Bit Position  | Error Type  |
|---|---|
| <b>Error Indication for Frames with MAC Error (byte 0, bit 3 = ERR, byte 0, bit 2 = don't care)</b> |   |
| 7   | Undefined, reserved for future use, set to 0 <sub>B</sub> |
| 6   | Receive Error   |
| 5   | Is Pause Frame  |
| 4   | FCS Error   |
| 3   | Length Error  |
| 2   | Alignment Error   |
| 1   | Frame too Long  |
| 0   | Frame too Short   |
| <b>Violation Indication for Dropped Frames (byte 0, bit 3 = OK, byte 0, bit 2 = DROP)</b>           |   |
| 0   | Egress Port State Violation                               |
| 1   | Ingress Port-State Violation                              |
| 2   | Port-Lock Violation                                       |
| 3   | MAC Learning Limitation Violation                         |
| 4   | VLAN Egress Membership Violation                          |
| 5   | VLAN Ingress Membership Violation                         |
| 6   | VLAN Ingress Tag Rule Violation                           |
| 7   | Unknown VLAN Violation                                    |
| <b>Flow Indication for Good Frames (byte 0.3 = OK, byte 0.2 = FWD)</b>                              |   |
| 07:0  | Flow Identification                                       |

## 4 Registers

This chapter describes the registers.

### 4.1 Top Level PDI Registers

**Table 44 Registers Overview**

| Register Short Name                                  | Register Long Name                                       | Offset Address    | Page Number         |
|--|--|-------------------|---------------------|
| <b>Top Level PDI Registers, GPHY Shell Registers</b> |  |                   |                     |
| <a href="#">GPHY0_FCR</a>                            | GPHY0 Firmware Address Offset Register                   | F700 <sub>H</sub> | <a href="#">131</a> |
| <a href="#">GPHY0_CFG</a>                            | GPHY0 General Configuration Register                     | F701 <sub>H</sub> | <a href="#">132</a> |
| <a href="#">GPHY0_AFETX_CTRL</a>                     | GPHY0 AFE TX Path Control Register                       | F702 <sub>H</sub> | <a href="#">133</a> |
| <a href="#">GPHY0_FCR_SD</a>                         | GPHY0 Firmware Address Offset Shadow Register            | F703 <sub>H</sub> | <a href="#">134</a> |
| <a href="#">GPHY0_GPS</a>                            | GPHY0 General Pin-Strapping Register                     | F708 <sub>H</sub> | <a href="#">135</a> |
| <a href="#">GPHY0_BFDEV</a>                          | GPHY0 Base Frequency Deviation Configuration Register    | F709 <sub>H</sub> | <a href="#">136</a> |
| <a href="#">GPHY0_STATUS</a>                         | GPHY0 General Status Register                            | F70F <sub>H</sub> | <a href="#">137</a> |
| <a href="#">GPHY1_FCR</a>                            | GPHY1 Firmware Address Offset Register                   | F710 <sub>H</sub> | <a href="#">131</a> |
| <a href="#">GPHY1_CFG</a>                            | GPHY1 General Configuration Register                     | F711 <sub>H</sub> | <a href="#">132</a> |
| <a href="#">GPHY1_AFETX_CTRL</a>                     | GPHY1 AFE TX Path Control Register                       | F712 <sub>H</sub> | <a href="#">133</a> |
| <a href="#">GPHY1_FCR_SD</a>                         | GPHY1 Firmware Address Offset Shadow Register            | F713 <sub>H</sub> | <a href="#">134</a> |
| <a href="#">GPHY1_GPS</a>                            | GPHY1 General Pin-Strapping Register                     | F718 <sub>H</sub> | <a href="#">135</a> |
| <a href="#">GPHY1_BFDEV</a>                          | GPHY1 Base Frequency Deviation Configuration Register    | F719 <sub>H</sub> | <a href="#">136</a> |
| <a href="#">GPHY1_STATUS</a>                         | GPHY1 General Status Register                            | F71F <sub>H</sub> | <a href="#">137</a> |
| <b>Top Level PDI Registers, R(G)MII Registers</b>    |  |                   |                     |
| <a href="#">MII_CFG_5</a>                            | xMII Interface 5 Configuration Register                  | F100 <sub>H</sub> | <a href="#">138</a> |
| <a href="#">PCDU_5</a>                               | RGMI 5 Clock Delay Configuration Register                | F101 <sub>H</sub> | <a href="#">140</a> |
| <a href="#">RTXB_CTL_5</a>                           | xMII5 Interface Receive Transmit Buffer Control Register | F120 <sub>H</sub> | <a href="#">141</a> |
| <a href="#">MII_MUX_CFG</a>                          | Pin and Port Multiplexing Configuration                  | F130 <sub>H</sub> | <a href="#">142</a> |
| <a href="#">PKT_INS</a>                              | Packet Insertion Register                                | F140 <sub>H</sub> | <a href="#">143</a> |
| <a href="#">PKT_EXT_READ</a>                         | Packet Extraction Read Register                          | F141 <sub>H</sub> | <a href="#">144</a> |
| <a href="#">PKT_EXT_CMD</a>                          | Packet Extraction Command Register                       | F142 <sub>H</sub> | <a href="#">145</a> |
| <a href="#">PCDU5_TX_KVAL</a>                        | PCDU5 TX K Value   | F160 <sub>H</sub> | <a href="#">145</a> |
| <a href="#">PCDU5_TX_MREQ</a>                        | PCDU5 TX M Required                                      | F161 <sub>H</sub> | <a href="#">146</a> |
| <a href="#">PCDU5_TX_MBLK</a>                        | PCDU5 TX M Blank   | F162 <sub>H</sub> | <a href="#">146</a> |
| <a href="#">PCDU5_TX_DELLEN</a>                      | PCDU5 TX Delay Length                                    | F163 <sub>H</sub> | <a href="#">147</a> |
| <a href="#">PCDU5_RX_KVAL</a>                        | PCDU5 RX K Value   | F168 <sub>H</sub> | <a href="#">147</a> |
| <a href="#">PCDU5_RX_MREQ</a>                        | PCDU5 RX M Required                                      | F169 <sub>H</sub> | <a href="#">148</a> |

**Table 44 Registers Overview (cont'd)**

| Register Short Name                                   | Register Long Name                               | Offset Address    | Page Number         |
|---|--|-------------------|---------------------|
| <a href="#">PCDU5_RX_MBLK</a>                         | PCDU5 RX M Blank                                 | F16A <sub>H</sub> | <a href="#">148</a> |
| <a href="#">PCDU5_RX_DELLEN</a>                       | PCDU5 RX Delay Length                            | F16B <sub>H</sub> | <a href="#">149</a> |
| <b>Top Level PDI Registers, MDIO Master Registers</b> |  |                   |                     |
| <a href="#">GSWIP_CFG</a>                             | GSWIP Configuration Register                     | F400 <sub>H</sub> | <a href="#">150</a> |
| <a href="#">MMDIO_CTRL</a>                            | MDIO Master Control Register                     | F408 <sub>H</sub> | <a href="#">152</a> |
| <a href="#">MMDIO_READ</a>                            | MDIO Master Read Data Register                   | F409 <sub>H</sub> | <a href="#">153</a> |
| <a href="#">MMDIO_WRITE</a>                           | MDIO Master Write Data Register                  | F40A <sub>H</sub> | <a href="#">153</a> |
| <a href="#">MMDC_CFG_0</a>                            | MDC Master Clock Configuration Register 0        | F40B <sub>H</sub> | <a href="#">154</a> |
| <a href="#">MMDC_CFG_1</a>                            | MDC Master Clock Configuration Register 1        | F40C <sub>H</sub> | <a href="#">155</a> |
| <a href="#">PHY_ADDR_5</a>                            | PHY Address Register PORT 5                      | F410 <sub>H</sub> | <a href="#">164</a> |
| <a href="#">PHY_ADDR_4</a>                            | PHY Address Register PORT 4                      | F411 <sub>H</sub> | <a href="#">163</a> |
| <a href="#">PHY_ADDR_1</a>                            | PHY Address Register PORT 1                      | F414 <sub>H</sub> | <a href="#">161</a> |
| <a href="#">PHY_ADDR_0</a>                            | PHY Address Register PORT 0                      | F415 <sub>H</sub> | <a href="#">157</a> |
| <a href="#">MMDIO_STAT_0</a>                          | PHY MDIO Polling Status per PORT                 | F416 <sub>H</sub> | <a href="#">159</a> |
| <a href="#">MMDIO_STAT_1</a>                          | PHY MDIO Polling Status PORT 1                   | F417 <sub>H</sub> | <a href="#">160</a> |
| <a href="#">MMDIO_STAT_5</a>                          | PHY MDIO Polling Status PORT 5                   | F41B <sub>H</sub> | <a href="#">160</a> |
| <a href="#">ANEG_EEE_0</a>                            | EEE Auto-Negotiation Overrides PORT 0            | F41D <sub>H</sub> | <a href="#">166</a> |
| <a href="#">ANEG_EEE_1</a>                            | EEE Auto-Negotiation Overrides PORT 1            | F41E <sub>H</sub> | <a href="#">166</a> |
| <a href="#">ANEG_EEE_5</a>                            | EEE Auto-Negotiation Overrides PORT 5            | F422 <sub>H</sub> | <a href="#">166</a> |
| <b>Top Level PDI Registers, MDIO Slave Registers</b>  |  |                   |                     |
| <a href="#">SMDIO_CFG</a>                             | MDC Slave Configuration Register                 | F480 <sub>H</sub> | <a href="#">167</a> |
| <a href="#">SMDIO_BADR</a>                            | MDC Slave Target Base Address Register           | F481 <sub>H</sub> | <a href="#">168</a> |
| <b>Top Level PDI Registers, SPI Master Registers</b>  |  |                   |                     |
| <a href="#">MSPI_CFG</a>                              | SPI Master Interface Configuration Register      | F510 <sub>H</sub> | <a href="#">169</a> |
| <a href="#">MSPI_OP</a>                               | SPI Master Operating Mode Configuration Register | F511 <sub>H</sub> | <a href="#">170</a> |
| <a href="#">MSPI_MANCTRL</a>                          | SPI Master Manual Mode Control Register          | F512 <sub>H</sub> | <a href="#">171</a> |
| <a href="#">MSPI_ISR</a>                              | SPI Master Interrupt Status Register             | F513 <sub>H</sub> | <a href="#">172</a> |
| <a href="#">MSPI_IER</a>                              | SPI Master Interrupt Enable Register             | F514 <sub>H</sub> | <a href="#">173</a> |
| <a href="#">MSPI_DIN01</a>                            | SPI Master Data In 0/1 Register                  | F518 <sub>H</sub> | <a href="#">173</a> |
| <a href="#">MSPI_DIN23</a>                            | SPI Master Data In 2/3 Register                  | F519 <sub>H</sub> | <a href="#">174</a> |
| <a href="#">MSPI_DIN67</a>                            | SPI Master Data In 6/7 Register                  | F51B <sub>H</sub> | <a href="#">175</a> |
| <a href="#">MSPI_DOUT01</a>                           | SPI Master Data Out 0/1 Register                 | F51C <sub>H</sub> | <a href="#">175</a> |
| <a href="#">MSPI_DOUT23</a>                           | SPI Master Data Out 2/3 Register                 | F51D <sub>H</sub> | <a href="#">176</a> |
| <a href="#">MSPI_DOUT45</a>                           | SPI Master Data Out 4/5 Register                 | F51E <sub>H</sub> | <a href="#">176</a> |
| <a href="#">MSPI_DOUT67</a>                           | SPI Master Data Out 6/7 Register                 | F51F <sub>H</sub> | <a href="#">177</a> |
| <a href="#">MSPI_DIN45</a>                            | SPI Master Data In 4/5 Register                  | F51A <sub>H</sub> | <a href="#">174</a> |
| <b>Top Level PDI Registers, SPI Slave Registers</b>   |  |                   |                     |
| <a href="#">SSPI_CFG</a>                              | SPI Slave Configuration Register                 | F580 <sub>H</sub> | <a href="#">178</a> |



**Table 44 Registers Overview (cont'd)**

| Register Short Name   | Register Long Name                           | Offset Address    | Page Number         |
|---|--|-------------------|---------------------|
| <b>Top Level PDI Registers, UART Registers</b>                  |  |                   |                     |
| <a href="#">UART_CFG</a>  | UART Configuration Register                  | F680 <sub>H</sub> | <a href="#">179</a> |
| <a href="#">UART_BD</a>   | UART Baud Rate Register                      | F681 <sub>H</sub> | <a href="#">180</a> |
| <a href="#">UART_FDIV</a>                                       | UART Baud Rate Fractional Divider Register   | F682 <sub>H</sub> | <a href="#">181</a> |
| <a href="#">UART_PROMPT</a>                                     | UART PROPMP Register                         | F683 <sub>H</sub> | <a href="#">182</a> |
| <a href="#">UART_ERRCNT</a>                                     | UART Error Counter Register                  | F684 <sub>H</sub> | <a href="#">183</a> |
| <b>Top Level PDI Registers, Clock Generation Unit Registers</b> |  |                   |                     |
| <a href="#">ROPLL_MISC</a>                                      | RO PLL Miscellaneous Control Register        | F990 <sub>H</sub> | <a href="#">189</a> |
| <a href="#">GPC0_CONF</a>                                       | GPC0 Configuration Register                  | F948 <sub>H</sub> | <a href="#">191</a> |
| <a href="#">GPC1_CONF</a>                                       | GPC1 Configuration Register                  | F94C <sub>H</sub> | <a href="#">192</a> |
| <a href="#">SYSCCLK_CONF</a>                                    | SYCCLK Configuration Register                | F950 <sub>H</sub> | <a href="#">192</a> |
| <a href="#">SGMII_CONF</a>                                      | SGMII Configuration Register                 | F954 <sub>H</sub> | <a href="#">193</a> |
| <a href="#">NCO1_LSB</a>  | NCO1 LSB Configuration Register              | F958 <sub>H</sub> | <a href="#">194</a> |
| <a href="#">NCO1_MSB</a>  | NCO1 MSB Configuration Register              | F95C <sub>H</sub> | <a href="#">194</a> |
| <a href="#">NCO2_LSB</a>  | NCO2 LSB Configuration Register              | F960 <sub>H</sub> | <a href="#">195</a> |
| <a href="#">NCO2_MSB</a>  | NCO2 MSB Configuration Register              | F964 <sub>H</sub> | <a href="#">195</a> |
| <a href="#">NCO_CTRL</a>  | NCO Control                                  | F968 <sub>H</sub> | <a href="#">196</a> |
| <a href="#">ROPLL_CFG0</a>                                      | RO PLL Configuration 0 Register              | F980 <sub>H</sub> | <a href="#">183</a> |
| <a href="#">ROPLL_CFG1</a>                                      | RO PLL Configuration 1 Register              | F984 <sub>H</sub> | <a href="#">184</a> |
| <a href="#">ROPLL_CFG2</a>                                      | RO PLL Configuration Register 2              | F988 <sub>H</sub> | <a href="#">185</a> |
| <a href="#">ROPLL_CFG3</a>                                      | RO PLL Configuration Register 3              | F98C <sub>H</sub> | <a href="#">188</a> |
| <b>Top Level PDI Registers, Reset Control Unit Registers</b>    |  |                   |                     |
| <a href="#">RESET_STATUS</a>                                    | Reset Status Register                        | FA00 <sub>H</sub> | <a href="#">197</a> |
| <a href="#">RST_REQ</a>   | Reset Request Register                       | FA01 <sub>H</sub> | <a href="#">197</a> |
| <a href="#">MANU_ID</a>   | MANU ID Register                             | FA10 <sub>H</sub> | <a href="#">199</a> |
| <a href="#">PNUM_ID</a>   | PNUM ID Register                             | FA11 <sub>H</sub> | <a href="#">200</a> |
| <a href="#">GPIO_DRIVE0_CFG</a>                                 | GPIO PAD Driver Strength 0 Control Register  | FA70 <sub>H</sub> | <a href="#">201</a> |
| <a href="#">GPIO_DRIVE1_CFG</a>                                 | GPIO PAD Driver Strength 1 Control Register  | FA71 <sub>H</sub> | <a href="#">201</a> |
| <a href="#">GPIO_SLEW_CFG</a>                                   | GPIO PAD Slew Control Register               | FA72 <sub>H</sub> | <a href="#">202</a> |
| <a href="#">GPIO2_DRIVE0_CFG</a>                                | GPIO2 PAD Driver Strength 0 Control Register | FA74 <sub>H</sub> | <a href="#">202</a> |
| <a href="#">GPIO2_DRIVE1_CFG</a>                                | GPIO2 PAD Driver Strength 1 Control Register | FA75 <sub>H</sub> | <a href="#">203</a> |
| <a href="#">GPIO2_SLEW_CFG</a>                                  | GPIO2 Slew Control Register                  | FA76 <sub>H</sub> | <a href="#">204</a> |
| <a href="#">RGMII_SLEW_CFG</a>                                  | RGMII PAD Slew Control Register              | FA78 <sub>H</sub> | <a href="#">204</a> |
| <a href="#">PS0</a>   | Pin-Strapping Register                       | FA80 <sub>H</sub> | <a href="#">206</a> |
| <a href="#">PS1</a>   | Pin-Strapping Register 1                     | FA81 <sub>H</sub> | <a href="#">206</a> |
| <b>Top Level PDI Registers, GPIO Registers</b>                  |  |                   |                     |
| <a href="#">GPIO_ALTSEL0</a>                                    | Port 0 Alternate Function Select Register 0  | F383 <sub>H</sub> | <a href="#">208</a> |
| <a href="#">GPIO_ALTSEL1</a>                                    | Port 0 Alternate Function Select Register 1  | F384 <sub>H</sub> | <a href="#">209</a> |

**Table 44 Registers Overview (cont'd)**

| Register Short Name                           | Register Long Name                          | Offset Address    | Page Number         |
|---|---|-------------------|---------------------|
| <a href="#">GPIO_PUDSEL</a>                   | GPIO Pull-Up/Pull-Down Select Register      | F386 <sub>H</sub> | <a href="#">209</a> |
| <a href="#">GPIO2_ALTSEL0</a>                 | Port 2 Alternate Function Select Register 0 | F393 <sub>H</sub> | <a href="#">212</a> |
| <a href="#">GPIO2_ALTSEL1</a>                 | Port 2 Alternate Function Select Register 1 | F394 <sub>H</sub> | <a href="#">213</a> |
| <a href="#">GPIO2_PUDSEL</a>                  | GPIO2 Pull-Up/Pull-Down Select Register     | F396 <sub>H</sub> | <a href="#">213</a> |
| <a href="#">GPIO_OUT</a>                      | GPIO Data Output Register                   | F380 <sub>H</sub> | <a href="#">207</a> |
| <a href="#">GPIO_IN</a>                       | GPIO Data Input Register                    | F381 <sub>H</sub> | <a href="#">207</a> |
| <a href="#">GPIO_DIR</a>                      | GPIO Direction Register                     | F382 <sub>H</sub> | <a href="#">208</a> |
| <a href="#">GPIO_OD</a>                       | GPIO Open Drain Control Register            | F385 <sub>H</sub> | <a href="#">209</a> |
| <a href="#">GPIO_PUDEN</a>                    | GPIO Pull-Up/Pull-Down Enable Register      | F387 <sub>H</sub> | <a href="#">210</a> |
| <a href="#">GPIO2_OUT</a>                     | GPIO2 Data Output Register                  | F390 <sub>H</sub> | <a href="#">211</a> |
| <a href="#">GPIO2_IN</a>                      | GPIO2 Data Input Register                   | F391 <sub>H</sub> | <a href="#">211</a> |
| <a href="#">GPIO2_DIR</a>                     | GPIO2 Direction Register                    | F392 <sub>H</sub> | <a href="#">212</a> |
| <a href="#">GPIO2_OD</a>                      | GPIO2 Open Drain Control Register           | F395 <sub>H</sub> | <a href="#">213</a> |
| <a href="#">GPIO2_PUDEN</a>                   | GPIO2 Pull-Up/Pull-Down Enable Register     | F397 <sub>H</sub> | <a href="#">214</a> |
| <b>Top Level PDI Registers, ICU Registers</b> |   |                   |                     |
| <a href="#">IM0_ISR</a>                       | IM0 Interrupt Status Register               | F3C0 <sub>H</sub> | <a href="#">215</a> |
| <a href="#">IM0_EINT0_IER</a>                 | IM0 EINT0 Interrupt Enable Register         | F3C2 <sub>H</sub> | <a href="#">215</a> |
| <a href="#">IM0_EINT1_IER</a>                 | IM0 EINT1 Interrupt Enable Register         | F3C3 <sub>H</sub> | <a href="#">216</a> |
| <a href="#">EIU_EXIN_CONF</a>                 | EIU External Interrupt Controller Register  | F3C4 <sub>H</sub> | <a href="#">217</a> |
| <b>Top Level PDI Registers, LED Registers</b> |   |                   |                     |
| <a href="#">LED_MD_CFG</a>                    | LED Single Color LED Mode Register          | F3E0 <sub>H</sub> | <a href="#">219</a> |
| <a href="#">LED_BRT_CTRL</a>                  | LED Brightness Control Register             | F3E1 <sub>H</sub> | <a href="#">221</a> |
| <a href="#">LED_LSENS_CTRL</a>                | LED Light Sensing Control Register          | F3E2 <sub>H</sub> | <a href="#">221</a> |

The register is addressed wordwise.

**Table 45 Register Access Types**

| Mode   | Symbol |
|--|--------|
| Interrupt status register, latching high, cleared by writing a ONE | lhsc   |
| Hardware status, read-only   | rh     |
| Read/write register with input from and output to hardware         | rwh    |
| Standard read/write register with output to hardware               | rw     |

### 4.1.1 GPHY Shell Registers

This section provides the registers required for GPHY configuration.

#### GPHY0 Firmware Address Offset Configuration Register

This register is used to store GPHY0 firmware address offset.

| GPHY0_FCR                              |            | Offset            | Reset Value       |
|--|------------|-------------------|-------------------|
| GPHY0 Firmware Address Offset Register |            | F700 <sub>H</sub> | 4000 <sub>H</sub> |
| 15                                     | 14         | 13                | 8                 |
| <b>MEMSEL</b>                          | <b>INV</b> | <b>FCR</b>        |                   |
| rw                                     | rw         | rw                |                   |
| 7                                      |            |                   | 0                 |
| <b>FCR</b>                             |            |                   |                   |
| rw                                     |            |                   |                   |

| Field  | Bits | Type | Description  |
|--------|------|------|--|
| MEMSEL | 15   | rw   | <b>GPHY Code Memory Mode</b><br>0 <sub>B</sub> <b>INT</b> GPHY macro loads firmware memory from internal ROM or internal RAM.<br>1 <sub>B</sub> <b>EXTROM</b> GPHY macro loads firmware memory by external E2PROM. |
| INV    | 14   | rw   | <b>Firmware Address Inversion</b><br>0 <sub>B</sub> <b>NOINV</b> Firmware address is not inverted.<br>1 <sub>B</sub> <b>INV</b> Firmware address is inverted when access internal ROM or internal RAM.             |
| FCR    | 13:0 | rw   | <b>Firmware Address Offset MSB</b><br>It stores PHY0 firmware offset address bits 17 to 4. The lower 4 address bits are 0.   |

#### Similar Registers

The following registers are identical to the Register [GPHY0\\_FCR](#) defined above.

**Table 46 Similar Registers**

| Register Short Name | Register Long Name                     | Offset Address    | Page Number |
|---------------------|--|-------------------|-------------|
| GPHY1_FCR           | GPHY1 Firmware Address Offset Register | F710 <sub>H</sub> |             |

**GPHY0 General Configuration Register**

This register is used to store GPHY0 general configuration register.

| GPHY0_CFG                                   | Offset                  | Reset Value             |
|---|-------------------------|-------------------------|
| <b>GPHY0 General Configuration Register</b> | <b>F701<sub>H</sub></b> | <b>0000<sub>H</sub></b> |
| 15  | Res                     | 8                       |
| 7   | Res                     | 0                       |
|   | 2                       | 1                       |
|   | IDCNMI                  | MDINTP                  |
|   | rwh                     | rw                      |

| Field  | Bits | Type | Description   |
|--------|------|------|---|
| IDCNMI | 1    | rwh  | <b>IDC Non-maskable Interrupt</b><br>This is a non-maskable interrupt to the IDC. As such this is the highest priority interrupt possible. It can be used for emergency applications. This signal is cleared when interrupt is acknowledged.<br>0 <sub>B</sub> <b>NIL</b> NMI interrupt is not pending.<br>1 <sub>B</sub> <b>INT</b> NMI interrupt is pending.  |
| MDINTP | 0    | rw   | <b>MDIO Interrupt Polarity</b><br>This type of information is evaluated by the integrated controller to allow configuration of the MDIO interrupt polarity by the instantiating SOC. For automatic configuration of the MDIO Interrupt polarity this configuration bit could be connected to the input of the MDIO interrupt pad. This field must be configured to 0 <sub>B</sub> .<br>0 <sub>B</sub> <b>HIGH</b> MDIO Interrupt is active high.<br>1 <sub>B</sub> <b>LOW</b> MDIO Interrupt is active low. |

**Similar Registers**

The following registers are identical to the Register [GPHY0\\_CFG](#) defined above.

**Table 47 Similar Registers**

| Register Short Name | Register Long Name                   | Offset Address    | Page Number |
|---------------------|--------------------------------------|-------------------|-------------|
| GPHY1_CFG           | GPHY1 General Configuration Register | F711 <sub>H</sub> |             |

**GPHY0 AFE TX Path Control Register**

This register is used to store the control information for GPHY0 AFE TX Path.

| GPHY0_AFETX_CTRL                          | Offset                  | Reset Value             |
|---|-------------------------|-------------------------|
| <b>GPHY0 AFE TX Path Control Register</b> | <b>F702<sub>H</sub></b> | <b>0000<sub>H</sub></b> |
| 15  |                         | 8                       |
|   | <b>Res</b>              |                         |
| 7   |                         | 0                       |
|   | <b>AFETX</b>            |                         |
|   | <b>rw</b>               |                         |

| Field | Bits | Type | Description  |
|-------|------|------|--|
| AFETX | 7:0  | rw   | <b>Control for AFE TX</b><br>Use this input to configure AFE TX path parameters. |

**Similar Registers**

The following registers are identical to the Register [GPHY0\\_AFETX\\_CTRL](#) defined above.

**Table 48 Similar Registers**

| Register Short Name | Register Long Name                 | Offset Address    | Page Number |
|---------------------|------------------------------------|-------------------|-------------|
| GPHY1_AFETX_CTRL    | GPHY1 AFE TX Path Control Register | F712 <sub>H</sub> |             |

**GPHY0 Firmware Address Offset Configuration Shadow Register**

This register is used to store GPHY0 firmware address offset shadow value.

| GPHY0_FCR_SD                                  | Offset            | Reset Value       |
|---|-------------------|-------------------|
| GPHY0 Firmware Address Offset Shadow Register | F703 <sub>H</sub> | 4000 <sub>H</sub> |

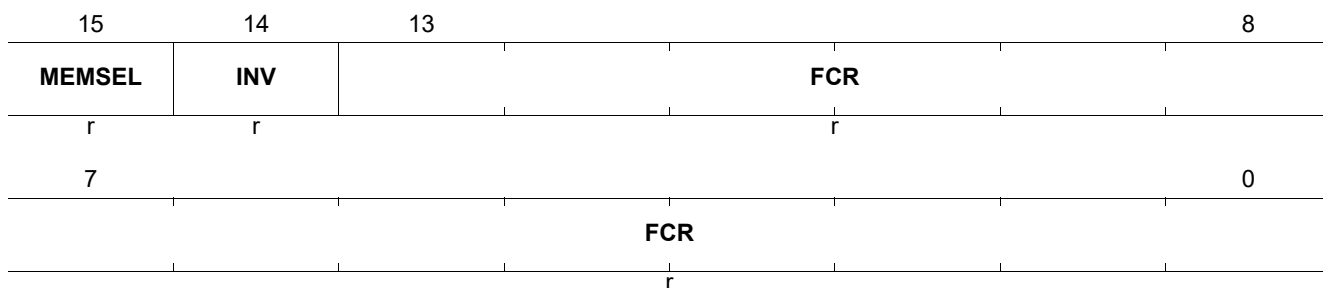

| Field  | Bits | Type | Description  |
|--------|------|------|--|
| MEMSEL | 15   | r    | <b>GPHY Code Memory Mode</b><br>0 <sub>B</sub> <b>INT</b> GPHY Macro loads firmware memory from internal ROM or internal RAM.<br>1 <sub>B</sub> <b>EXTROM</b> GPHY Macro loads firmware memory by external E2PROM. |
| INV    | 14   | r    | <b>Firmware Address Inversion</b><br>0 <sub>B</sub> <b>NOINV</b> Firmware address is not inverted.<br>1 <sub>B</sub> <b>INV</b> Firmware address is inverted when access internal ROM or internal RAM.             |
| FCR    | 13:0 | r    | <b>Firmware Address Offset MSB</b><br>It stores PHY0 firmware offset address bits 17 to 4. The lower 4 address bits are 0.   |

**Similar Registers**

The following registers are identical to the Register [GPHY0\\_FCR\\_SD](#) defined above.

**Table 49 Similar Registers**

| Register Short Name | Register Long Name                            | Offset Address    | Page Number |
|---------------------|---|-------------------|-------------|
| GPHY1_FCR_SD        | GPHY1 Firmware Address Offset Shadow Register | F713 <sub>H</sub> |             |

**GPHY0 General Pin-Strapping Register**

This register is used to store general pin-strapping configuration register.

| <b>GPHY0_GPS</b>                            | <b>Offset</b>           | <b>Reset Value</b>      |
|---|-------------------------|-------------------------|
| <b>GPHY0 General Pin-Strapping Register</b> | <b>F708<sub>H</sub></b> | <b>00FF<sub>H</sub></b> |
| 15  |                         | 8                       |
|   | <b>Res</b>              |                         |
| 7   |                         | 0                       |
|   | <b>GPS</b>              |                         |
|   | <b>rw</b>               |                         |

| <b>Field</b> | <b>Bits</b> | <b>Type</b> | <b>Description</b>   |
|--------------|-------------|-------------|--|
| GPS          | 7:0         | rw          | <b>General Pin-Strapping</b><br>This connects GPHY general pin-strapping bit 7 to 0. |

**Similar Registers**

The following registers are identical to the Register [GPHY0\\_GPS](#) defined above.

**Table 50 Similar Registers**

| <b>Register Short Name</b> | <b>Register Long Name</b>            | <b>Offset Address</b> | <b>Page Number</b> |
|----------------------------|--------------------------------------|-----------------------|--------------------|
| GPHY1_GPS                  | GPHY1 General Pin-Strapping Register | F718 <sub>H</sub>     |                    |

**GPHY0 Base Frequency Deviation Configuration Register**

This register is used to store base frequency deviation configuration register.

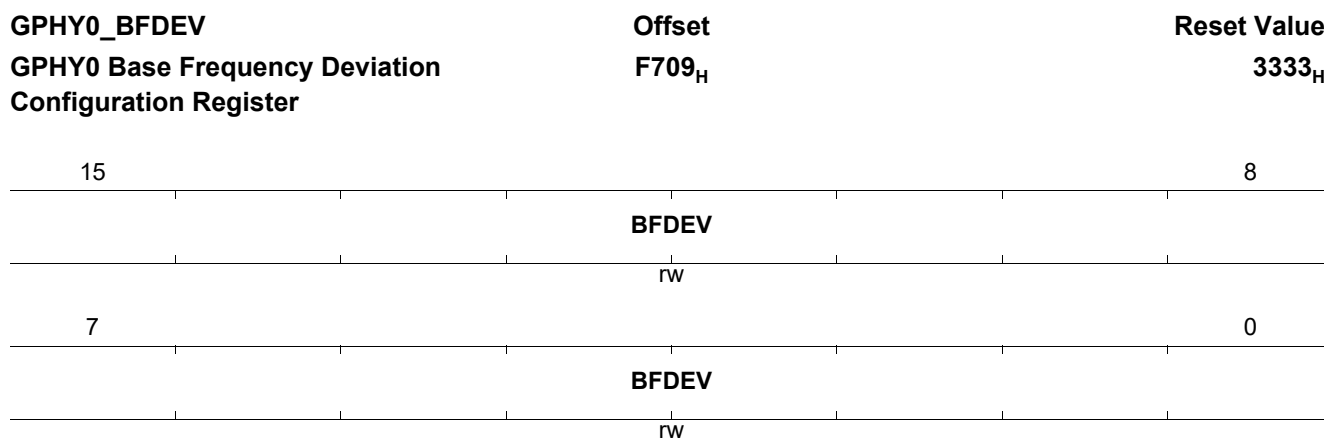

| Field | Bits | Type | Description  |
|-------|------|------|--|
| BFDEV | 15:0 | rw   | <b>Base Frequency Deviation</b><br>Use this input to specify base frequency deviation from nominal base. |

**Similar Registers**

The following registers are identical to the Register [GPHY0\\_BFDEV](#) defined above.

**Table 51 Similar Registers**

| Register Short Name | Register Long Name                                    | Offset Address    | Page Number |
|---------------------|---|-------------------|-------------|
| GPHY1_BFDEV         | GPHY1 Base Frequency Deviation Configuration Register | F719 <sub>H</sub> |             |



**GPHY0 General Status Register**

This register is used to store GPHY0 general status register.

| GPHY0_STATUS                         | Offset                  | Reset Value             |
|--------------------------------------|-------------------------|-------------------------|
| <b>GPHY0 General Status Register</b> | <b>F70F<sub>H</sub></b> | <b>0000<sub>H</sub></b> |
| 15                                   |                         | 8                       |
| Res                                  |                         |                         |
| 7                                    | 2                       | 1 0                     |
| Res                                  |                         | IDCPWD                  |
|                                      |                         | IDCIDLE                 |
|                                      |                         | r r                     |

| Field   | Bits | Type | Description   |
|---------|------|------|---|
| IDCPWD  | 1    | r    | <b>IDC Power Down</b><br>0 <sub>B</sub> PUP IDC is powered up.<br>1 <sub>B</sub> PDOWN IDC is powered down. |
| IDCIDLE | 0    | r    | <b>IDC Idle</b><br>0 <sub>B</sub> ACT IDC is active.<br>1 <sub>B</sub> IDLE IDC is idle.                    |

**Similar Registers**

The following registers are identical to the Register [GPHY0\\_STATUS](#) defined above.

**Table 52 Similar Registers**

| Register Short Name | Register Long Name            | Offset Address    | Page Number |
|---------------------|-------------------------------|-------------------|-------------|
| GPHY1_STATUS        | GPHY1 General Status Register | F71F <sub>H</sub> |             |

### 4.1.2 R(G)MII Registers

This section provides the control registers of the R(G)MII Interfaces.

#### xMII Interface 5 Configuration Register

This register controls the settings of the xMII Interface.

| MII_CFG_5                               |                | Offset            |                | Reset Value       |            |    |                |
|---|----------------|-------------------|----------------|-------------------|------------|----|----------------|
| xMII Interface 5 Configuration Register |                | F100 <sub>H</sub> |                | 2044 <sub>H</sub> |            |    |                |
| 15                                      | 14             | 13                | 12             | 11                | 10         | 9  | 8              |
| <b>RST</b>                              | <b>EN</b>      | <b>ISOL</b>       | <b>CLKDIS</b>  | <b>Res</b>        | <b>CRS</b> |    | <b>RGMIIBS</b> |
| rwh                                     | rw             | rw                | rw             |                   |            | rw | rw             |
| 7                                       | 6              | 4                 |                | 3                 |            |    | 0              |
| <b>RMII</b>                             | <b>MIIRATE</b> |                   | <b>MIIMODE</b> |                   |            |    |                |
|   |                | rw                |                | rw                |            |    |                |

| Field  | Bits | Type | Description  |
|--------|------|------|--|
| RST    | 15   | rwh  | <b>Hardware Reset</b><br>Resets all related hardware modules except for the register settings. This reset acts similar to the hardware reset, but maintains any programming of the control registers.<br>0 <sub>B</sub> <b>OFF</b> reset is off<br>1 <sub>B</sub> <b>ON</b> reset is active  |
| EN     | 14   | rw   | <b>xMII Interface Enable</b><br>The corresponding interface can only be enabled when the disable signal at macro boundary is inactive. Otherwise the interface is disabled.<br>0 <sub>B</sub> <b>DIS</b> disable the interface<br>1 <sub>B</sub> <b>EN</b> enable the interface  |
| ISOL   | 13   | rw   | <b>ISOLATE xMII Interface</b><br>Set to 0 for normal operation. In ISOLATE all xMII Output Pins are set to be disabled<br>0 <sub>B</sub> <b>EN</b> Interface is active<br>1 <sub>B</sub> <b>ISO</b> Interface outputs are isolated   |
| CLKDIS | 12   | rw   | <b>Link Down Clock Disable</b><br>For power save in case of link down signaled by MDIO, the clocks in the xMII module and in the xMII Interface can be switched off automatically. The automatic switching off can be enabled by setting this parameter to "On".<br>0 <sub>B</sub> <b>OFF</b> No automatic disable in case of link down<br>1 <sub>B</sub> <b>ON</b> Disable clocks in case of link down and switch interface off |

| Field     | Bits | Type | Description  |
|-----------|------|------|--|
| CRS       | 10:9 | rw   | <b>CRS Sensitivity Configuration</b><br>These Bits are only valid in PHY Mode. CRS can be configured depending on RX and TX activity and Half/Full Duplex Modes (HDX/FDX)<br>00 <sub>B</sub> <b>MD0</b> HDX:TX+RX, FDX:RX<br>01 <sub>B</sub> <b>MD1</b> HDX:TX+RX, FDX:0<br>10 <sub>B</sub> <b>MD2</b> HDX:RX, FDX:RX<br>11 <sub>B</sub> <b>MD3</b> HDX:RX, FDX:0  |
| RGMII_IBS | 8    | rw   | <b>RGMII In Band Status</b><br>When RGMII mode is selected, this bit controls whether the In Band Status Bits Link, Clock Speed duplex are transmitted during IPG<br>Could be set to "On" in case of connected to an external MAC.<br>RGMII in band status extraction is always on regardless of this setting.<br>0 <sub>B</sub> <b>OFF</b> RGMII In Band Status is off<br>1 <sub>B</sub> <b>ON</b> RGMII In Band Status is on |
| RMII      | 7    | rw   | <b>RMII Reference Clock Direction of the Interface</b><br>If RMII mode is selected, this bit controls the clock source of the interface.<br>This bit is ignored in other interface operation modes.<br>0 <sub>B</sub> <b>IN</b> RMII clock is input<br>1 <sub>B</sub> <b>OUT</b> RMII clock is output  |
| MIIRATE   | 6:4  | rw   | <b>xMII Interface Clock Rate</b><br>Selects the data and clock rate for the xMII interface.<br>In RMII mode, 50 MHz must always be selected.<br>000 <sub>B</sub> <b>M2P5</b> 2.5 MHz<br>001 <sub>B</sub> <b>M25</b> 25 MHz<br>010 <sub>B</sub> <b>M125</b> 125 MHz<br>011 <sub>B</sub> <b>M50</b> 50 MHz<br>100 <sub>B</sub> <b>Auto</b> Automatically clock rate based on speed   |
| MIIMODE   | 3:0  | rw   | <b>xMII Interface Mode</b><br>This selects the xMII interface mode.<br>0011 <sub>B</sub> <b>RMII</b> RMII mode, connected to external PHY or MAC.<br>0100 <sub>B</sub> <b>RGMII</b> RGMII mode, connected to external PHY or MAC.  |

**RGMI 5 Clock Delay Configuration Register**

This register controls the settings of the receive and transmit clock delay.

| PCDU_5   | Offset                  | Reset Value             |
|--|-------------------------|-------------------------|
| <b>RGMI 5 Clock Delay Configuration Register</b> | <b>F101<sub>H</sub></b> | <b>0000<sub>H</sub></b> |
| 15   | 11                      | 10                      |
| Res  |                         | DELMD                   |
|  |                         | RXDLY                   |
|  |                         | rw                      |
| 7  | 6                       | 3                       |
| RXDLY  | Res                     |                         |
|  | TXDLY                   |                         |
| rw   | rw                      |                         |

| Field | Bits | Type | Description  |
|-------|------|------|--|
| DELMD | 10   | rw   | <b>PCDU Delay Setting Mode</b><br>0 <sub>B</sub> <b>DELAY</b> Setting clock delay directly<br>1 <sub>B</sub> <b>MK</b> Setting M, K values                             |
| RXDLY | 9:7  | rw   | <b>Configure Receive Clock Delay</b><br>Configure the delay of RX_CLK_D versus RX_CLK in steps of 500 ps.<br>The resulting delay is TD = unsigned(RXDLY) * 500 ps      |
| TXDLY | 2:0  | rw   | <b>Configure Transmit Clock Delay</b><br>Configure the delay of TX_CLK_D versus TX_CLK in steps of 500 ps.<br>The total configured delay is TD=unsigned(TXDLY)*500 ps. |

**xMII5 Interface Receive Transmit Buffer Control Register**

This register is used to configure the internal receive buffer and check under and overflow.

|   |                         |                         |
|---|-------------------------|-------------------------|
| <b>RTXB_CTL_5</b>   | <b>Offset</b>           | <b>Reset Value</b>      |
| <b>xMII5 Interface Receive Transmit Buffer Control Register</b> | <b>F120<sub>H</sub></b> | <b>0009<sub>H</sub></b> |

|                 |                    |                 |                 |                    |    |
|-----------------|--------------------|-----------------|-----------------|--------------------|----|
| 15              | 14                 | 13              | 12              | 11                 | 8  |
| <b>TBUF_UFL</b> | <b>TBUF_OFL</b>    | <b>RBUF_UFL</b> | <b>RBUF_OFL</b> | <b>Res</b>         |    |
| lhsc            | lhsc               | lhsc            | ihsc            |                    |    |
| 7               | 6                  | 5               | 3               | 2                  | 0  |
| <b>Res</b>      | <b>TBUF_DLY_WP</b> |                 |                 | <b>RBUF_DLY_WP</b> |    |
|                 |                    |                 | rw              |                    | rw |

| Field           | Bits | Type | Description   |
|-----------------|------|------|---|
| TBUF_UFL        | 15   | lhsc | <b>Transmit Buffer Underflow Indicator</b><br>Indicates when one or more transmit buffer underflow events have been detected.<br>0 <sub>B</sub> <b>NONE</b> Underflow never detected<br>1 <sub>B</sub> <b>UFL</b> Underflow occurred at least once  |
| TBUF_OFL        | 14   | lhsc | <b>Transmit Buffer Overflow Indicator</b><br>Indicates when one or more transmit buffer overflow events have been detected.<br>0 <sub>B</sub> <b>NONE</b> Overflow never detected<br>1 <sub>B</sub> <b>OFL</b> Overflow occurred at least once  |
| RBUF_UFL        | 13   | lhsc | <b>Receive Buffer Underflow Indicator</b><br>Indicates when one or more receive buffer underflow events have been detected.<br>0 <sub>B</sub> <b>NONE</b> Underflow is never detected<br>1 <sub>B</sub> <b>UFL</b> Underflow occurred at least once   |
| RBUF_OFL        | 12   | lhsc | <b>Receive Buffer Overflow Indicator</b><br>Indicates when one or more receive buffer overflow events have been detected.<br>0 <sub>B</sub> <b>NONE</b> Overflow is never detected<br>1 <sub>B</sub> <b>OFL</b> Overflow occurred at least once   |
| TBUF_DLY_WP     | 5:3  | rw   | <b>TX Buffer Delay Write Pointer</b><br>This register is used to configure the initial delay of the write pointer in the transmit buffer.<br>This delay must be larger than zero to support negative frequency offsets.<br>This delay must be smaller than max to support positive frequency offsets. |
| RBUF_DLY_W<br>P | 2:0  | rw   | <b>RX Buffer Delay Write Pointer</b><br>This register is used to configure the initial delay of the write pointer in the receive buffer.<br>This delay must be larger than zero to support negative frequency offsets.<br>This delay must be smaller than max to support positive frequency offsets.  |

**Pin and Port Multiplexing Configuration**

This register is used to configure Pin and Port Multiplexing.

| MII_MUX_CFG                             | Offset            | Reset Value       |
|---|-------------------|-------------------|
| Pin and Port Multiplexing Configuration | F130 <sub>H</sub> | 0000 <sub>H</sub> |
| 15                                      | 10                | 9                 |
|   | <b>Res</b>        | <b>PIE</b>        |
|   |                   | <b>Res</b>        |
|   |                   | rw                |
| 7                                       |                   | 1                 |
|   | <b>Res</b>        |                   |
|   |                   | <b>GPHY0_ISO</b>  |
|   |                   | rw                |

| Field     | Bits | Type | Description   |
|-----------|------|------|---|
| PIE       | 9    | rw   | <b>Packet Insertion and Extraction Mode</b><br>This is to select packet insertion and extraction mode.<br>0 <sub>B</sub> <b>DIS</b> Packet insertion and extraction mode is disabled.<br>1 <sub>B</sub> <b>EN</b> Packet insertion and extraction mode is enabled. GSWIP port 6 is connected to packet insertion and extraction mode. |
| GPHY0_ISO | 0    | rw   | <b>GPHY0 Isolation Mode</b><br>This is to enable or disable GPHY isolation mode.<br>0 <sub>B</sub> <b>DIS</b> Isolation mode is disabled, GPHY0 is connected to switch fabric.<br>1 <sub>B</sub> <b>EN</b> Isolation mode is enabled, GPHY0 is connected to RGMII5.   |

**Packet Insertion Register**

This register is used to insert packet to port 6.

| PKT_INS                   |    | Offset            | Reset Value       |
|---------------------------|----|-------------------|-------------------|
| Packet Insertion Register |    | F140 <sub>H</sub> | 0000 <sub>H</sub> |
| 15                        | 14 | 9                 | 8                 |
| <b>INSCMD</b>             |    | <b>Res</b>        | <b>RXVD</b>       |
| rwh                       |    |                   | rw                |
| 7                         |    |                   | 0                 |
|                           |    | <b>RXD</b>        |                   |
|                           |    | rw                |                   |

| Field  | Bits | Type | Description   |
|--------|------|------|---|
| INSCMD | 15   | rwh  | <b>Packet Insertion Command</b><br>0 <sub>B</sub> <b>NIL</b> Packet insertion is not triggered.<br>1 <sub>B</sub> <b>CMD</b> Start Packet insertion. CPU write '1' to this bit to trigger the insertion. This is a single cycle pulse and the bit is self clearing. |
| RXVD   | 8    | rw   | <b>RX Valid</b><br>This is to indicate whether the data byte is valid or not.<br>0 <sub>B</sub> <b>GAP</b> The data byte is not valid. Writing IPG.<br>1 <sub>B</sub> <b>VLD</b> The data byte is valid. Writing Preamble, SFD and packet data.                     |
| RXD    | 7:0  | rw   | <b>RX Data</b><br>Data Byte to be inserted. Including IPG, Preamble, SFD and packet data.   |

### Packet Extraction Read Register

This register is used to extract packet from port 6.

| PKT_EXT_READ                    |    | Offset            | Reset Value       |
|---------------------------------|----|-------------------|-------------------|
| Packet Extraction Read Register |    | F141 <sub>H</sub> | 0000 <sub>H</sub> |
| 15                              | 14 |                   | 9                 |
| <b>AVAIL</b>                    |    | <b>Res</b>        | <b>TXEN</b>       |
| rh                              |    |                   | rh                |
| 7                               |    |                   | 0                 |
|                                 |    | <b>TXD</b>        |                   |
|                                 |    | rh                |                   |

| Field | Bits | Type | Description  |
|-------|------|------|--|
| AVAIL | 15   | rh   | <b>Packet Available</b><br>This is to indicate a new packet is available to be extracted. When packet available, an interrupt is set.<br>0 <sub>B</sub> <b>NAVL</b> Packet is not available to be available.<br>1 <sub>B</sub> <b>AVL</b> Packet is available to be available. |
| TXEN  | 8    | rh   | <b>TX Data Valid</b><br>This is to indicate the extracted data byte is valid<br>0 <sub>B</sub> <b>NIL</b> The extracted byte is not valid<br>1 <sub>B</sub> <b>EN</b> The extracted byte is valid.   |
| TXD   | 7:0  | rh   | <b>TX Data</b><br>Data byte extracted.   |



**Packet Extraction Command Register**

This register is used to extract packet from port 6.

| PKT_EXT_CMD                        | Offset            | Reset Value       |
|------------------------------------|-------------------|-------------------|
| Packet Extraction Command Register | F142 <sub>H</sub> | 0000 <sub>H</sub> |
| 15                                 |                   | 8                 |
|                                    | Res               |                   |
| 7                                  |                   | 0                 |
|                                    | Res               | FLUSH             |
|                                    |                   | rwh               |

| Field | Bits | Type | Description   |
|-------|------|------|---|
| FLUSH | 0    | rwh  | <b>Packet Extraction Flush Command</b><br>This is to indicate to flush the rest of the current packet<br>0 <sub>B</sub> <b>NIL</b> The flush command is not triggered<br>1 <sub>B</sub> <b>CMD</b> The flush command is triggered. This bit is self-clearing and it is cleared until the flush of the current packet is done. |

**PCDU5 TX K Value Register**

This register is used to configure TX K value.

| PCDU5_TX_KVAL    | Offset            | Reset Value       |
|------------------|-------------------|-------------------|
| PCDU5 TX K Value | F160 <sub>H</sub> | 0040 <sub>H</sub> |
| 15               |                   | 8                 |
|                  | KVAL              |                   |
|                  | rw                |                   |
| 7                |                   | 0                 |
|                  | KVAL              |                   |
|                  | rw                |                   |

| Field | Bits | Type | Description                      |
|-------|------|------|----------------------------------|
| KVAL  | 15:0 | rw   | <b>K Value for TX Delay Path</b> |

**PCDU5 TX M Required Register**

This register is used to configure TX M Required.

| PCDU5_TX_MREQ       | Offset            | Reset Value       |
|---------------------|-------------------|-------------------|
| PCDU5 TX M Required | F161 <sub>H</sub> | 0000 <sub>H</sub> |
| 15                  |                   | 8                 |
|                     | MREQ              |                   |
|                     | rw                |                   |
| 7                   |                   | 0                 |
|                     | MREQ              |                   |
|                     | rw                |                   |

| Field | Bits | Type | Description                  |
|-------|------|------|------------------------------|
| MREQ  | 15:0 | rw   | M Required for TX Delay Path |

**PCDU5 TX M Blank Register**

This register is used to configure TX M Blank.

| PCDU5_TX_MBLK    | Offset            | Reset Value       |
|------------------|-------------------|-------------------|
| PCDU5 TX M Blank | F162 <sub>H</sub> | 0002 <sub>H</sub> |
| 15               |                   | 8                 |
|                  | MBLK              |                   |
|                  | rw                |                   |
| 7                |                   | 0                 |
|                  | MBLK              |                   |
|                  | rw                |                   |

| Field | Bits | Type | Description               |
|-------|------|------|---------------------------|
| MBLK  | 15:0 | rw   | M Blank for TX Delay Path |

**PCDU5 TX Delay Length Register**

This register is used to configure TX Delay Length.

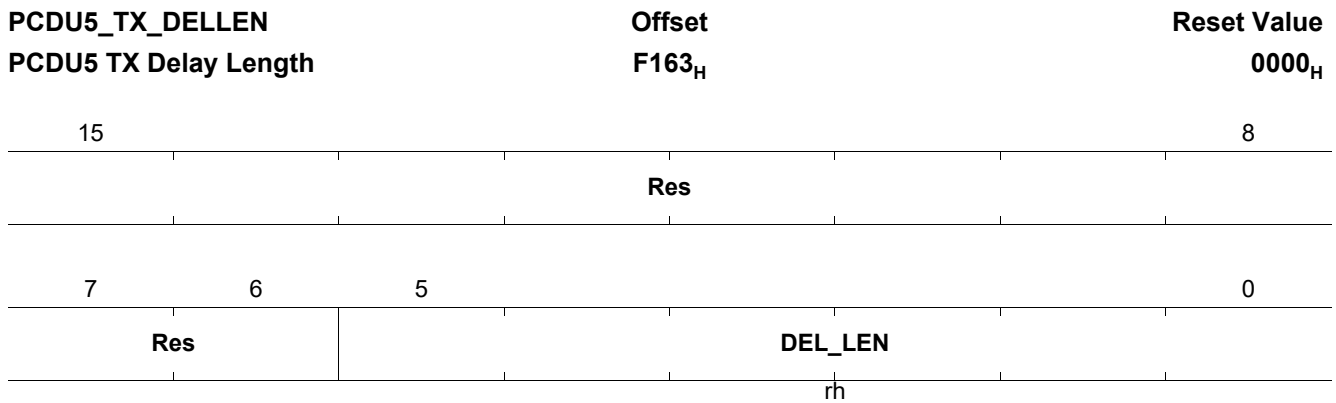

| Field   | Bits | Type | Description                    |
|---------|------|------|--------------------------------|
| DEL_LEN | 5:0  | rh   | Delay Length for TX Delay Path |

**PCDU 5 RX K Value Register**

This register is used to configure RX K value.

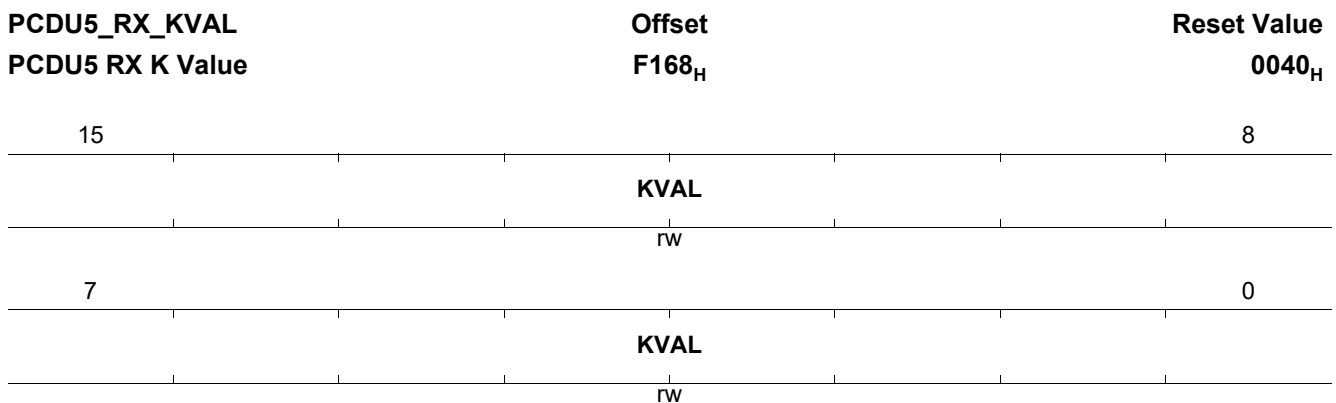

| Field | Bits | Type | Description               |
|-------|------|------|---------------------------|
| KVAL  | 15:0 | rw   | K Value for RX Delay Path |

**PCDU5 RX M Required Register**

This register is used to configure RX M Required.

| PCDU5_RX_MREQ       | Offset            | Reset Value       |
|---------------------|-------------------|-------------------|
| PCDU5 RX M Required | F169 <sub>H</sub> | 0000 <sub>H</sub> |
| 15                  |                   | 8                 |
|                     | MREQ              |                   |
|                     | rw                |                   |
| 7                   |                   | 0                 |
|                     | MREQ              |                   |
|                     | rw                |                   |

| Field | Bits | Type | Description                  |
|-------|------|------|------------------------------|
| MREQ  | 15:0 | rw   | M Required for RX Delay Path |

**PCDU5 RX M Blank Register**

This register is used to configure RX M Blank.

| PCDU5_RX_MBLK    | Offset            | Reset Value       |
|------------------|-------------------|-------------------|
| PCDU5 RX M Blank | F16A <sub>H</sub> | 0002 <sub>H</sub> |
| 15               |                   | 8                 |
|                  | MBLK              |                   |
|                  | rw                |                   |
| 7                |                   | 0                 |
|                  | MBLK              |                   |
|                  | rw                |                   |

| Field | Bits | Type | Description               |
|-------|------|------|---------------------------|
| MBLK  | 15:0 | rw   | M Blank for RX Delay Path |

### PCDU5 RX Delay Length Register

This register is used to configure RX Delay Length.

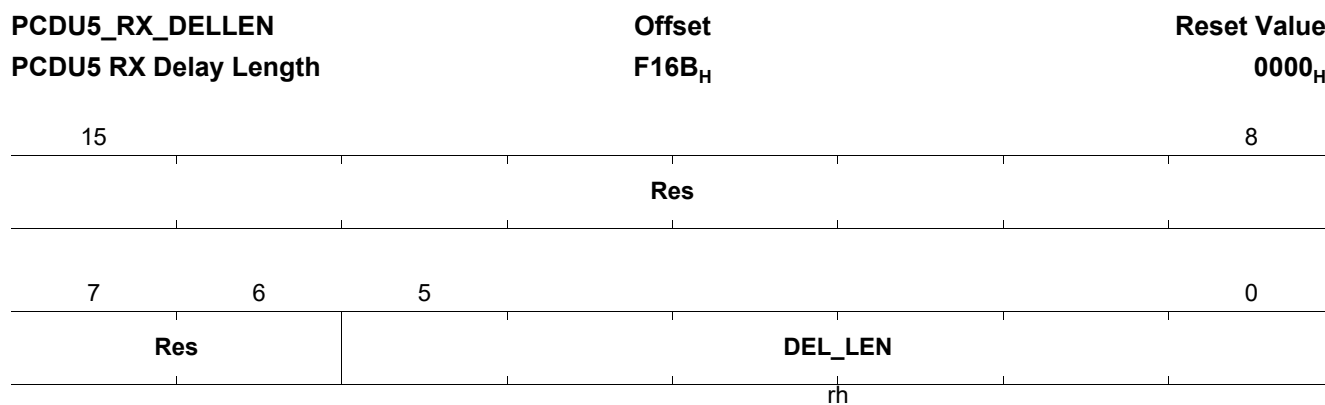

| Field   | Bits | Type | Description                    |
|---------|------|------|--------------------------------|
| DEL_LEN | 5:0  | rh   | Delay Length for RX Delay Path |

### 4.1.3 MDIO Master Registers

This section provides the registers required to control the MDIO Master Interface.

#### GSWIP Configuration Register

This register is used to configuration GSWIP port enable and disable.

| GSWIP_CFG                    |           |           |            |           |           |              | Offset            | Reset Value       |
|------------------------------|-----------|-----------|------------|-----------|-----------|--------------|-------------------|-------------------|
| GSWIP Configuration Register |           |           |            |           |           |              | F400 <sub>H</sub> | 0000 <sub>H</sub> |
| 15                           | 14        | 13        | 12         | 11        | 10        | 9            | 8                 |                   |
| <b>SE</b>                    | <b>P6</b> | <b>P5</b> | <b>P4</b>  | <b>P3</b> | <b>P2</b> | <b>P1</b>    | <b>P0</b>         |                   |
| rw                           | rw        | rw        | rw         | rw        | rw        | rw           | rw                |                   |
| 7                            |           |           |            |           | 2         | 1            | 0                 |                   |
|                              |           |           | <b>Res</b> |           |           | <b>HWRES</b> | <b>SWRES</b>      |                   |
|                              |           |           |            |           |           | rw           | rw                |                   |

| Field | Bits | Type | Description  |
|-------|------|------|--|
| SE    | 15   | rw   | <b>Global Switch Macro Enable</b><br>When set to OFF, the switch macro is inactive and frame forwarding is disabled. Register configuration and memory access is enabled in the OFF state. A register programming must activate the switch by setting this bit. This is used for setting all relevant registers before enabling the data traffic<br>0 <sub>B</sub> <b>Disable</b> Macro is disabled<br>1 <sub>B</sub> <b>Enable</b> Macro is enabled |
| P6    | 14   | rw   | <b>Port 6 Disable Configuration</b><br>0 <sub>B</sub> <b>Enable</b> Port is enabled<br>1 <sub>B</sub> <b>Disable</b> Port is disabled  |
| P5    | 13   | rw   | <b>Port 5 Disable Configuration</b><br>0 <sub>B</sub> <b>Enable</b> Port is enabled<br>1 <sub>B</sub> <b>Disable</b> Port is disabled  |
| P4    | 12   | rw   | <b>Port 4 Disable Configuration</b><br>0 <sub>B</sub> <b>Enable</b> Port is enabled<br>1 <sub>B</sub> <b>Disable</b> Port is disabled  |
| P3    | 11   | rw   | <b>Port 3 Disable Configuration</b><br>0 <sub>B</sub> <b>Enable</b> Port is enabled<br>1 <sub>B</sub> <b>Disable</b> Port is disabled  |
| P2    | 10   | rw   | <b>Port 2 Disable Configuration</b><br>0 <sub>B</sub> <b>Enable</b> Port is enabled<br>1 <sub>B</sub> <b>Disable</b> Port is disabled  |
| P1    | 9    | rw   | <b>Port 1 Disable Configuration</b><br>0 <sub>B</sub> <b>Enable</b> Port is enabled<br>1 <sub>B</sub> <b>Disable</b> Port is disabled  |

| Field | Bits | Type | Description  |
|-------|------|------|--|
| P0    | 8    | rw   | <b>Port 0 Disable Configuration</b><br>0 <sub>B</sub> <b>Enable</b> Port is enabled<br>1 <sub>B</sub> <b>Disable</b> Port is disabled  |
| HWRES | 1    | rwh  | <b>Global Switch Macro Hardware Reset</b><br>Reset all hardware modules including the register settings. This reset acts similar to the hardware reset and is cleared by HW after Reset is executed.<br>0 <sub>B</sub> <b>OFF</b> Reset is off<br>1 <sub>B</sub> <b>ON</b> Reset is active   |
| SWRES | 0    | rwh  | <b>Global Switch Macro Software Reset</b><br>Reset all GSWIP hardware modules excluding the register settings. This reset acts similar to the hardware reset, but maintains any programming of the control registers and is cleared by HW after Reset is executed.<br>0 <sub>B</sub> <b>OFF</b> Reset is off<br>1 <sub>B</sub> <b>ON</b> Reset is active |

**MDIO Master Indirect Control Register**

This register is used to access devices connected to the serial MDIO master interface, internally or externally. Each write access to this register starts a transmission, either read or write.

| MMDIO_CTRL                          | Offset                  | Reset Value             |           |    |              |   |
|-------------------------------------|-------------------------|-------------------------|-----------|----|--------------|---|
| <b>MDIO Master Control Register</b> | <b>F408<sub>H</sub></b> | <b>0000<sub>H</sub></b> |           |    |              |   |
| 15                                  | 13                      | 12                      | 11        | 10 | 9            | 8 |
| <b>Res</b>                          |                         | <b>MBUSY</b>            | <b>OP</b> |    | <b>PHYAD</b> |   |
|                                     |                         | rh                      | rw        |    | rw           |   |
| 7                                   | 5                       | 4                       | 0         |    |              |   |
| <b>PHYAD</b>                        |                         | <b>REGAD</b>            |           |    |              |   |
| rw                                  |                         | rw                      |           |    |              |   |

| Field | Bits  | Type | Description   |
|-------|-------|------|---|
| MBUSY | 12    | rh   | <b>MDIO Busy</b><br>This bit is set by hardware upon each write access to the register, which starts a transmission.<br>As soon as a new command can be accepted, this bit is cleared by hardware.<br>During write access, this bit is ignored and can be written to either value, 0 or 1.<br>0 <sub>B</sub> <b>IDLE</b> The bus is available<br>1 <sub>B</sub> <b>BUSY</b> The bus is busy |
| OP    | 11:10 | rw   | <b>Operation Code</b><br>Selects the operation command. The value is directly mapped into the serial access frame.<br>00 <sub>B</sub> <b>RES0</b> Reserved, do not use<br>01 <sub>B</sub> <b>WR</b> Write access<br>10 <sub>B</sub> <b>RD</b> Read access<br>11 <sub>B</sub> <b>RES3</b> Reserved, do not use   |
| PHYAD | 9:5   | rw   | <b>PHY Address</b><br>PHY address of the target device. The value is directly mapped into the serial access frame.  |
| REGAD | 4:0   | rw   | <b>Register Address</b><br>Register address in the target device. The value is directly mapped into the serial access frame.  |



**MDIO Master Indirect Read Data Register**

This register is used to read back data across the serial MDIO master interface, internally or externally.

| MMDIO_READ                            | Offset                  | Reset Value             |
|---------------------------------------|-------------------------|-------------------------|
| <b>MDIO Master Read Data Register</b> | <b>F409<sub>H</sub></b> | <b>0000<sub>H</sub></b> |
| 15                                    |                         | 8                       |
| <b>RDATA</b>                          |                         |                         |
| rh                                    |                         |                         |
| 7                                     |                         | 0                       |
| <b>RDATA</b>                          |                         |                         |
| rh                                    |                         |                         |

| Field | Bits | Type | Description   |
|-------|------|------|---|
| RDATA | 15:0 | rh   | <b>Read Data</b><br>A read access is triggered by writing to MDIO_CTRL (OP = RD, MBUSY = BUSY). After MBUSY = IDLE, data can be read. |

**MDIO Master Indirect Write Data Register**

This register is used to write data across the serial MDIO master interface, internally or externally.

| MMDIO_WRITE                            | Offset                  | Reset Value             |
|--|-------------------------|-------------------------|
| <b>MDIO Master Write Data Register</b> | <b>F40A<sub>H</sub></b> | <b>0000<sub>H</sub></b> |
| 15                                     |                         | 8                       |
| <b>WDATA</b>                           |                         |                         |
| rw                                     |                         |                         |
| 7                                      |                         | 0                       |
| <b>WDATA</b>                           |                         |                         |
| rw                                     |                         |                         |

| Field | Bits | Type | Description   |
|-------|------|------|---|
| WDATA | 15:0 | rw   | <b>Write Data</b><br>A write access is triggered by writing to MDIO_CTRL (OP = WR, MBUSY = BUSY).<br>This register must be written before the write command is given. |

**MDC Master Configuration Register 0**

This register is used to control the MDC clock output and polling state machine.

| MMDC_CFG_0                                | Offset            | Reset Value       |
|---|-------------------|-------------------|
| MDC Master Clock Configuration Register 0 | F40B <sub>H</sub> | 006F <sub>H</sub> |
| 15  |                   | 8                 |
| Res                                       |                   |                   |
| 7   | 6                 | 0                 |
| Res                                       | PEN               |                   |
| rw  |                   |                   |

| Field | Bits | Type | Description   |
|-------|------|------|---|
| PEN   | 6:0  | rw   | <b>Polling State Machine Enable</b><br>Enables the state machine to read PHY information automatically on this port. Unused ports must be disabled to reduce the polling latency.<br>0 <sub>B</sub> <b>DIS</b> Automatic PHY polling is disabled on this port<br>1 <sub>B</sub> <b>EN</b> Automatic PHY polling is enabled on this port (default) |

**MDC Master Clock Configuration Register 1**

This register is used to configure clocking rate for the MDIO master interfaces.

| MMDC_CFG_1                                |    | Offset            | Reset Value       |
|---|----|-------------------|-------------------|
| MDC Master Clock Configuration Register 1 |    | F40C <sub>H</sub> | 0109 <sub>H</sub> |
| 15  | 14 |                   | 9                 |
| <b>RST</b>                                |    | <b>GAP</b>        | <b>MCEN</b>       |
| rwh                                       |    | rw                | rw                |
| 7   |    |                   | 0                 |
|   |    | <b>FREQ</b>       |                   |
|   |    | rw                |                   |

| Field | Bits | Type | Description  |
|-------|------|------|--|
| RST   | 15   | rwh  | <b>MDIO Hardware Reset</b><br>Reset all hardware modules except for the register settings. This reset acts similar to the hardware reset, but maintains any programming of the control registers and is cleared by HW after Reset is executed.<br>0 <sub>B</sub> <b>OFF</b> Reset is off<br>1 <sub>B</sub> <b>ON</b> Reset is active   |
| GAP   | 14:9 | rw   | <b>Autopolling Gap</b><br>This register configures the number of cycles between each auto-polling read access. The number of MDIO clock cycles is 256* <b>GAP</b> .  |
| MCEN  | 8    | rw   | <b>Management Clock Enable</b><br>Enables the MDC clock driver. The driver can be disabled to save power when no external devices are connected to the MDIO master interface. When the MDC clock is disabled, the MDIO pad is switched to input mode and the MDIO drivers are also disabled.<br>0 <sub>B</sub> <b>DIS</b> Clock driver is disabled<br>1 <sub>B</sub> <b>EN</b> Clock driver is enabled (default) |

| Field | Bits | Type | Description   |
|-------|------|------|---|
| FREQ  | 7:0  | rw   | <p><b>MDIO Interface Clock Rate</b></p> <p>Selects the interface data and clock rate for the MDIO master interface. The MDC clock frequency calculates as:<br/> <math>f_{MDC} = \text{Sys\_clock\_freq} / 5 / ((\text{value} + 1) * 2)</math>.</p> <p>This frequency changes when system clock frequency changes. The following values are the frequencies when system clock is 340 MHz.</p> <p>00000000<sub>B</sub> <b>S0</b> 34.0 MHz<br/>           00000001<sub>B</sub> <b>S1</b> 17.0 MHz<br/>           00000010<sub>B</sub> <b>S2</b> 11.333 MHz<br/>           00000011<sub>B</sub> <b>S3</b> 8.50 MHz<br/>           00000100<sub>B</sub> <b>S4</b> 6.80 MHz<br/>           00000101<sub>B</sub> <b>S5</b> 5.66 MHz<br/>           00000110<sub>B</sub> <b>S6</b> 4.86 MHz<br/>           00000111<sub>B</sub> <b>S7</b> 4.25 MHz<br/>           00001000<sub>B</sub> <b>S8</b> 3.78 MHz<br/>           00001001<sub>B</sub> <b>S9</b> 3.4 MHz<br/>           00001010<sub>B</sub> <b>S10</b> 3.09 MHz<br/>           00001011<sub>B</sub> <b>S11</b> 2.83 MHz<br/>           00001100<sub>B</sub> <b>S12</b> 2.61 MHz<br/>           00001101<sub>B</sub> <b>S13</b> 2.43 MHz<br/>           00001110<sub>B</sub> <b>S14</b> 2.27 MHz<br/>           00001111<sub>B</sub> <b>S15</b> 2.13 MHz<br/>           11111111<sub>B</sub> <b>S255</b> 132.8 kHz</p> |

**PHY Address Register PORT 0**

This register is used to define the PHY address of the port.

When autopolling in MMDC\_CFG\_1 is disabled, the modes defined here are used instead of the polling values

| PHY_ADDR_0                  |    | Offset            |    | Reset Value       |    |             |   |               |
|-----------------------------|----|-------------------|----|-------------------|----|-------------|---|---------------|
| PHY Address Register PORT 0 |    | F415 <sub>H</sub> |    | 1800 <sub>H</sub> |    |             |   |               |
| 15                          | 14 | 13                | 12 | 11                | 10 | 9           | 8 |               |
| <b>AUTO_SEL</b>             |    | <b>LNKST</b>      |    | <b>SPEED</b>      |    | <b>FDUP</b> |   | <b>FCONTX</b> |
| rw                          |    | rw                |    | rw                |    | rw          |   | rw            |
| 7                           | 6  | 5                 | 4  |                   |    | 0           |   |               |
| <b>FCONTX</b>               |    | <b>FCONRX</b>     |    | <b>ADDR</b>       |    |             |   |               |
| rw                          |    | rw                |    | rw                |    |             |   |               |

| Field    | Bits  | Type | Description   |
|----------|-------|------|---|
| AUTO_SEL | 15    | rw   | <b>Information Source for Automatic Mode</b><br>0 <sub>B</sub> <b>POLLING</b> MDIO autopolling results are used for final link information<br>1 <sub>B</sub> <b>GPHY</b> GPHY link information outputs are used for final link information  |
| LNKST    | 14:13 | rw   | <b>Link Status Control</b><br>00 <sub>B</sub> <b>AUTO</b> Automatic mode detection by MDIO autopolling (AUTO_SEL = 0) or by GPHY link information outputs (AUTO_SEL = 1)<br>01 <sub>B</sub> <b>UP</b> The link status is forced up<br>10 <sub>B</sub> <b>DOWN</b> The link status is forced down<br>11 <sub>B</sub> <b>RES</b> Reserved, do not use |
| SPEED    | 12:11 | rw   | <b>Speed Control</b><br>00 <sub>B</sub> <b>M10</b> Data Rate 10 Mbps<br>01 <sub>B</sub> <b>M100</b> Data Rate 100 Mbps<br>10 <sub>B</sub> <b>G1</b> Data Rate 1 Gbps<br>11 <sub>B</sub> <b>AUTO</b> Automatic mode detection by MDIO autopolling (AUTO_SEL = 0) or by GPHY link information outputs (AUTO_SEL = 1)                                  |
| FDUP     | 10:9  | rw   | <b>Full Duplex Control</b><br>00 <sub>B</sub> <b>AUTO</b> Automatic mode detection by MDIO autopolling (AUTO_SEL = 0) or by GPHY link information outputs (AUTO_SEL = 1)<br>01 <sub>B</sub> <b>EN</b> Full duplex mode<br>10 <sub>B</sub> <b>RES</b> Reserved<br>11 <sub>B</sub> <b>DIS</b> Half duplex mode  |

| Field  | Bits | Type | Description   |
|--------|------|------|---|
| FCONTX | 8:7  | rw   | <b>Flow Control Mode TX</b><br>00 <sub>B</sub> <b>AUTO</b> Automatic mode detection by MDIO autopolling (AUTO_SEL = 0) or by GPHY link information outputs (AUTO_SEL = 1)<br>01 <sub>B</sub> <b>EN</b> Flow control in receive (ingress direction) only<br>10 <sub>B</sub> <b>RES</b> Reserved<br>11 <sub>B</sub> <b>DIS</b> Flow control in transmit (egress direction) only |
| FCONRX | 6:5  | rw   | <b>Flow Control Mode RX</b><br>00 <sub>B</sub> <b>AUTO</b> Automatic mode detection by MDIO autopolling (AUTO_SEL = 0) or by GPHY link information outputs (AUTO_SEL = 1)<br>01 <sub>B</sub> <b>EN</b> Flow control in receive (ingress direction) only<br>10 <sub>B</sub> <b>RES</b> Reserved<br>11 <sub>B</sub> <b>DIS</b> Flow control in transmit (egress direction) only |
| ADDR   | 4:0  | rw   | <b>PHY Address</b><br>Default value is based on <a href="#">Table 10</a> .  |

**PHY MDIO Polling Status PORT 0**

This register provides information about the current status of the attached Ethernet PHY retrieved by using the auto-polling process.

This status information is retrieved from the attached Ethernet PHY by polling the related MDIO register.

| MMDIO_STAT_0                   |      | Offset            |       | Reset Value       |       |                      |         |
|--------------------------------|------|-------------------|-------|-------------------|-------|----------------------|---------|
| PHY MDIO Polling Status PORT 0 |      | F416 <sub>H</sub> |       | 0000 <sub>H</sub> |       |                      |         |
| 15                             |      | 11                |       | 10                | 9     | 8                    |         |
| Res                            |      |                   |       | RXACT             | TXACT | CLK_STOP_C<br>APABLE |         |
|                                |      |                   |       | ihsc              | ihsc  | rh                   |         |
| 7                              | 6    | 5                 | 4     | 3                 | 2     | 1                    | 0       |
| EEE_CAPAB<br>LE                | PACT | LSTAT             | SPEED |                   | FDUP  | RXPAUEN              | TXPAUEN |
| rh                             | rh   | rh                | rh    |                   | rh    | rh                   | rh      |

| Field                | Bits | Type | Description   |
|----------------------|------|------|---|
| RXACT                | 10   | lhsc | <b>RX Traffic Active</b><br>When there is RX traffic (RXDV = '1'), this bit is set to 1 by hardware. uC can write '1' to this bit to clear it.<br>0 <sub>B</sub> <b>NOT Active</b> Not active<br>1 <sub>B</sub> <b>ACT</b> TX traffic is active   |
| TXACT                | 9    | lhsc | <b>TX Traffic Active</b><br>When there is TX traffic (TXEN = '1'), this bit is set to 1 by hardware. uC can write '1' to this bit to clear it.<br>0 <sub>B</sub> <b>NOT Active</b> Not active<br>1 <sub>B</sub> <b>ACT</b> TX traffic is active   |
| CLK_STOP_C<br>APABLE | 8    | rh   | <b>PHY Supports TX Clock Stop</b><br>0 <sub>B</sub> <b>DIS</b> Clock stop is not supported<br>1 <sub>B</sub> <b>EN</b> Clock is supported   |
| EEE_CAPAB<br>LE      | 7    | rh   | <b>PHY and Link Partner Support EEE for Current Speed</b><br>0 <sub>B</sub> <b>DIS</b> EEE is not supported<br>1 <sub>B</sub> <b>EN</b> EEE is supported  |
| PACT                 | 6    | rh   | <b>PHY Active Status</b><br>Indicates when the external PHY is responding to MDIO accesses. This status information is retrieved from the attached Ethernet PHY by polling MDIO registers.<br>0 <sub>B</sub> <b>INACTIVE</b> The PHY is inactive or not present<br>1 <sub>B</sub> <b>ACTIVE</b> The PHY is active and responds to MDIO accesses |
| LSTAT                | 5    | rh   | <b>Link Status</b><br>This status information is retrieved from the attached Ethernet PHY by polling the related MDIO register.<br>0 <sub>B</sub> <b>DOWN</b> The link is down<br>1 <sub>B</sub> <b>UP</b> The link is up   |

| Field   | Bits | Type | Description   |
|---------|------|------|---|
| SPEED   | 4:3  | rh   | <b>Speed Control</b><br>00 <sub>B</sub> <b>M10</b> Data Rate 10 Mbps<br>01 <sub>B</sub> <b>M100</b> Data Rate 100 Mbps<br>10 <sub>B</sub> <b>G1</b> Data Rate 1 Gbps or above<br>11 <sub>B</sub> <b>RES</b> Reserved  |
| FDUP    | 2    | rh   | <b>Full Duplex Status</b><br>Indicates when the attached PHY runs in half- or full-duplex mode. This status information is retrieved from the attached Ethernet PHY by polling the related MDIO register.<br>0 <sub>B</sub> <b>HALF</b> Half-duplex mode<br>1 <sub>B</sub> <b>FULL</b> Full-duplex mode |
| RXPAUEN | 1    | rh   | <b>Receive Pause Enable Status</b><br>This status information is retrieved from the attached Ethernet PHY by polling the related MDIO register.<br>0 <sub>B</sub> <b>DIS</b> The link partner does not send pause frames<br>1 <sub>B</sub> <b>EN</b> The link partner sends pause frames                |
| TXPAUEN | 0    | rh   | <b>Transmit Pause Enable Status</b><br>This status information is retrieved from the attached Ethernet PHY by polling the related MDIO register.<br>0 <sub>B</sub> <b>DIS</b> The link partner does not accept pause frames<br>1 <sub>B</sub> <b>EN</b> The link partner accepts pause frames           |

**Similar Registers**

The following registers are identical to the Register [MMDIO\\_STAT\\_0](#) defined above.

**Table 53 Similar Registers**

| Register Short Name | Register Long Name             | Offset Address    | Page Number |
|---------------------|--------------------------------|-------------------|-------------|
| MMDIO_STAT_1        | PHY MDIO Polling Status PORT 1 | F417 <sub>H</sub> |             |
| MMDIO_STAT_5        | PHY MDIO Polling Status PORT 5 | F41B <sub>H</sub> |             |



**PHY Address Register PORT 1**

This register is used to define the PHY address of the port.

When autopolling in MMDC\_CFG\_1 is disabled, the modes defined here are used instead of the polling values.

| PHY_ADDR_1                  | Offset            | Reset Value       |              |    |             |   |               |
|-----------------------------|-------------------|-------------------|--------------|----|-------------|---|---------------|
| PHY Address Register PORT 1 | F414 <sub>H</sub> | 1801 <sub>H</sub> |              |    |             |   |               |
| 15                          | 14                | 13                | 12           | 11 | 10          | 9 | 8             |
| <b>AUTO_SEL</b>             | <b>LNKST</b>      |                   | <b>SPEED</b> |    | <b>FDUP</b> |   | <b>FCONTX</b> |
| rw                          | rw                |                   | rw           |    | rw          |   | rw            |
| 7                           | 6                 | 5                 | 4            |    |             |   | 0             |
| <b>FCONTX</b>               | <b>FCONRX</b>     |                   | <b>ADDR</b>  |    |             |   |               |
| rw                          | rw                |                   | rw           |    |             |   |               |

| Field    | Bits  | Type | Description   |
|----------|-------|------|---|
| AUTO_SEL | 15    | rw   | <b>Information Source for Automatic Mode</b><br>0 <sub>B</sub> <b>POLLING</b> MDIO autopolling results are used for final link information<br>1 <sub>B</sub> <b>GPHY</b> GPHY link information outputs are used for final link information  |
| LNKST    | 14:13 | rw   | <b>Link Status Control</b><br>00 <sub>B</sub> <b>AUTO</b> Automatic mode detection by MDIO autopolling (AUTO_SEL = 0) or by GPHY link information outputs (AUTO_SEL = 1)<br>01 <sub>B</sub> <b>UP</b> The link status is forced up<br>10 <sub>B</sub> <b>DOWN</b> The link status is forced down<br>11 <sub>B</sub> <b>RES</b> Reserved, do not use |
| SPEED    | 12:11 | rw   | <b>Speed Control</b><br>00 <sub>B</sub> <b>M10</b> Data Rate 10 Mbps<br>01 <sub>B</sub> <b>M100</b> Data Rate 100 Mbps<br>10 <sub>B</sub> <b>G1</b> Data Rate 1 Gbps<br>11 <sub>B</sub> <b>AUTO</b> Automatic mode detection by MDIO autopolling (AUTO_SEL = 0) or by GPHY link information outputs (AUTO_SEL = 1)                                  |
| FDUP     | 10:9  | rw   | <b>Full Duplex Control</b><br>00 <sub>B</sub> <b>AUTO</b> Automatic mode detection by MDIO autopolling (AUTO_SEL = 0) or by GPHY link information outputs (AUTO_SEL = 1)<br>01 <sub>B</sub> <b>EN</b> Full duplex mode<br>10 <sub>B</sub> <b>RES</b> Reserved<br>11 <sub>B</sub> <b>DIS</b> Half duplex mode  |

| Field  | Bits | Type | Description   |
|--------|------|------|---|
| FCONTX | 8:7  | rw   | <b>Flow Control Mode TX</b><br>00 <sub>B</sub> <b>AUTO</b> Automatic mode detection by MDIO autopolling (AUTO_SEL = 0) or by GPHY link information outputs (AUTO_SEL = 1)<br>01 <sub>B</sub> <b>EN</b> Flow control in receive (ingress direction) only<br>10 <sub>B</sub> <b>RES</b> Reserved<br>11 <sub>B</sub> <b>DIS</b> Flow control in transmit (egress direction) only |
| FCONRX | 6:5  | rw   | <b>Flow Control Mode RX</b><br>00 <sub>B</sub> <b>AUTO</b> Automatic mode detection by MDIO autopolling (AUTO_SEL = 0) or by GPHY link information outputs (AUTO_SEL = 1)<br>01 <sub>B</sub> <b>EN</b> Flow control in receive (ingress direction) only<br>10 <sub>B</sub> <b>RES</b> Reserved<br>11 <sub>B</sub> <b>DIS</b> Flow control in transmit (egress direction) only |
| ADDR   | 4:0  | rw   | <b>PHY Address</b><br>Default value is based on <a href="#">Table 10</a> .  |

**PHY Address Register PORT 4**

This register is used to define the PHY address of the port.

When autopolling in MMDC\_CFG\_1 is disabled, the modes defined here are used instead of the polling values.

| PHY_ADDR_4                  | Offset            | Reset Value       |       |    |      |   |        |
|-----------------------------|-------------------|-------------------|-------|----|------|---|--------|
| PHY Address Register PORT 4 | F411 <sub>H</sub> | 1804 <sub>H</sub> |       |    |      |   |        |
| 15                          | 14                | 13                | 12    | 11 | 10   | 9 | 8      |
| Res                         | LNKST             |                   | SPEED |    | FDUP |   | FCONTX |
|                             | rw                |                   | rw    |    | rw   |   | rw     |
| 7                           | 6                 | 5                 | 4     |    |      |   | 0      |
| FCONTX                      | FCONRX            |                   | ADDR  |    |      |   |        |
| rw                          | rw                |                   | rw    |    |      |   |        |

| Field  | Bits  | Type | Description  |
|--------|-------|------|--|
| LNKST  | 14:13 | rw   | <b>Link Status Control</b><br>00 <sub>B</sub> <b>AUTO</b> Automatic mode detection by SGMII<br>01 <sub>B</sub> <b>UP</b> The link status is forced up<br>10 <sub>B</sub> <b>DOWN</b> The link status is forced down<br>11 <sub>B</sub> <b>RES</b> Reserved, do not use                                     |
| SPEED  | 12:11 | rw   | <b>Speed Control</b><br>00 <sub>B</sub> <b>M10</b> Data Rate 10 Mbps<br>01 <sub>B</sub> <b>M100</b> Data Rate 100 Mbps<br>10 <sub>B</sub> <b>G1</b> Data Rate 1 Gbps or above<br>11 <sub>B</sub> <b>AUTO</b> Automatic mode detection by SGMII   |
| FDUP   | 10:9  | rw   | <b>Full Duplex Control</b><br>00 <sub>B</sub> <b>AUTO</b> Automatic mode detection by SGMII<br>01 <sub>B</sub> <b>EN</b> Full duplex mode<br>10 <sub>B</sub> <b>RES</b> Reserved<br>11 <sub>B</sub> <b>DIS</b> Half duplex mode  |
| FCONTX | 8:7   | rw   | <b>Flow Control Mode TX</b><br>00 <sub>B</sub> <b>AUTO</b> Automatic mode detection SGMII<br>01 <sub>B</sub> <b>EN</b> Flow control in receive (ingress direction) only<br>10 <sub>B</sub> <b>RES</b> Reserved<br>11 <sub>B</sub> <b>DIS</b> Flow control in transmit (egress direction) only              |
| FCONRX | 6:5   | rw   | <b>Flow Control Mode RX</b><br>00 <sub>B</sub> <b>AUTO</b> Automatic mode detection by SGMII (default)<br>01 <sub>B</sub> <b>EN</b> Flow control in receive (ingress direction) only<br>10 <sub>B</sub> <b>RES</b> Reserved<br>11 <sub>B</sub> <b>DIS</b> Flow control in transmit (egress direction) only |
| ADDR   | 4:0   | rw   | <b>PHY Address</b><br>Default value is based on <a href="#">Table 10</a> .   |

**PHY Address Register PORT 5**

This register is used to define the PHY address of the port.

When autopolling in MMDC\_CFG\_1 is disabled, the modes defined here are used instead of the polling values.

| PHY_ADDR_5                  |               | Offset            | Reset Value       |    |             |   |               |
|-----------------------------|---------------|-------------------|-------------------|----|-------------|---|---------------|
| PHY Address Register PORT 5 |               | F410 <sub>H</sub> | 1805 <sub>H</sub> |    |             |   |               |
| 15                          | 14            | 13                | 12                | 11 | 10          | 9 | 8             |
| <b>AUTO_SEL</b>             | <b>LNKST</b>  |                   | <b>SPEED</b>      |    | <b>FDUP</b> |   | <b>FCONTX</b> |
| rw                          | rw            |                   | rw                |    | rw          |   | rw            |
| 7                           | 6             | 5                 | 4                 |    |             |   | 0             |
| <b>FCONTX</b>               | <b>FCONRX</b> |                   | <b>ADDR</b>       |    |             |   |               |
| rw                          | rw            |                   | rw                |    |             |   |               |

| Field    | Bits  | Type | Description   |
|----------|-------|------|---|
| AUTO_SEL | 15    | rw   | <b>Information Source for Automatic Mode</b><br>0 <sub>B</sub> <b>POLLING</b> MDIO autopolling results are used for final link information<br>1 <sub>B</sub> <b>GPHY</b> GPHY link information outputs are used for final link information  |
| LNKST    | 14:13 | rw   | <b>Link Status Control</b><br>00 <sub>B</sub> <b>AUTO</b> Automatic mode detection by MDIO autopolling (AUTO_SEL = 0) or by GPHY link information outputs (AUTO_SEL = 1)<br>01 <sub>B</sub> <b>UP</b> The link status is forced up<br>10 <sub>B</sub> <b>DOWN</b> The link status is forced down<br>11 <sub>B</sub> <b>RES</b> Reserved, do not use |
| SPEED    | 12:11 | rw   | <b>Speed Control</b><br>00 <sub>B</sub> <b>M10</b> Data Rate 10 Mbps<br>01 <sub>B</sub> <b>M100</b> Data Rate 100 Mbps<br>10 <sub>B</sub> <b>G1</b> Data Rate 1 Gbps<br>11 <sub>B</sub> <b>AUTO</b> Automatic mode detection by MDIO autopolling (AUTO_SEL = 0) or by GPHY link information outputs (AUTO_SEL = 1)                                  |
| FDUP     | 10:9  | rw   | <b>Full Duplex Control</b><br>00 <sub>B</sub> <b>AUTO</b> Automatic mode detection by MDIO autopolling (AUTO_SEL = 0) or by GPHY link information outputs (AUTO_SEL = 1)<br>01 <sub>B</sub> <b>EN</b> Full duplex mode<br>10 <sub>B</sub> <b>RES</b> Reserved<br>11 <sub>B</sub> <b>DIS</b> Half duplex mode  |

| Field  | Bits | Type | Description   |
|--------|------|------|---|
| FCONTX | 8:7  | rw   | <b>Flow Control Mode TX</b><br>00 <sub>B</sub> <b>AUTO</b> Automatic mode detection by MDIO autopolling (AUTO_SEL = 0) or by GPHY link information outputs (AUTO_SEL = 1)<br>01 <sub>B</sub> <b>EN</b> Flow control in receive (ingress direction) only<br>10 <sub>B</sub> <b>RES</b> Reserved<br>11 <sub>B</sub> <b>DIS</b> Flow control in transmit (egress direction) only |
| FCONRX | 6:5  | rw   | <b>Flow Control Mode RX</b><br>00 <sub>B</sub> <b>AUTO</b> Automatic mode detection by MDIO autopolling (AUTO_SEL = 0) or by GPHY link information outputs (AUTO_SEL = 1)<br>01 <sub>B</sub> <b>EN</b> Flow control in receive (ingress direction) only<br>10 <sub>B</sub> <b>RES</b> Reserved<br>11 <sub>B</sub> <b>DIS</b> Flow control in transmit (egress direction) only |
| ADDR   | 4:0  | rw   | <b>PHY Address</b><br>Default value is based on <a href="#">Table 10</a> .  |

### EEE Auto-Negotiation Overrides Port 0

Override what is conveyed to the MAC from the auto-negotiation with PHY.

| ANEG_EEE_0                            | Offset            | Reset Value       |
|---------------------------------------|-------------------|-------------------|
| EEE Auto-Negotiation Overrides Port 0 | F41D <sub>H</sub> | 0000 <sub>H</sub> |
| 15                                    |                   | 8                 |
| Res                                   |                   |                   |
| 7                                     | 4                 | 0                 |
|                                       | Res               | CLK_STOP_CAPABLE  |
|                                       | rw                | EEE_CAPABLE       |
|                                       |                   | rw                |

| Field                | Bits | Type | Description  |
|----------------------|------|------|--|
| CLK_STOP_C<br>APABLE | 3:2  | rw   | <b>Clock Stop Capable</b><br>00 <sub>B</sub> <b>AUTO</b> Automatic detection by autopolling<br>01 <sub>B</sub> <b>EN</b> Force capable on<br>10 <sub>B</sub> <b>RES</b> Reserved<br>11 <sub>B</sub> <b>DIS</b> Force capable off |
| EEE_CAPABL<br>E      | 1:0  | rw   | <b>EEE Capable</b><br>00 <sub>B</sub> <b>AUTO</b> Automatic detection by auto polling<br>01 <sub>B</sub> <b>EN</b> Force capable on<br>10 <sub>B</sub> <b>RES</b> Reserved<br>11 <sub>B</sub> <b>DIS</b> Force capable off       |

### Similar Registers

The following registers are identical to the Register [ANEG\\_EEE\\_0](#) defined above.

**Table 54** Similar Registers

| Register Short Name | Register Long Name                    | Offset Address    | Page Number |
|---------------------|---------------------------------------|-------------------|-------------|
| ANEG_EEE_1          | EEE Auto-Negotiation Overrides Port 1 | F41E <sub>H</sub> |             |
| ANEG_EEE_5          | EEE Auto-Negotiation Overrides Port 5 | F422 <sub>H</sub> |             |

#### 4.1.4 MDIO Slave Registers

This section provides the registers required to control the MDIO slave interface.

##### MDIO Slave Configuration

This register is used to configure MDIO slave interface.

| SMDIO_CFG                        |            | Offset            | Reset Value       |
|----------------------------------|------------|-------------------|-------------------|
| MDC Slave Configuration Register |            | F480 <sub>H</sub> | 01F1 <sub>H</sub> |
| 15                               | 14         | 9                 | 8                 |
| <b>RST</b>                       | <b>Res</b> |                   | <b>ADDR</b>       |
| rwh                              |            |                   | rw                |
| 7                                | 4          | 3                 | 2                 |
| <b>ADDR</b>                      |            | <b>Res</b>        | <b>PREN</b>       |
| rw                               |            |                   | rw                |
|                                  |            |                   | 0                 |
|                                  |            |                   | <b>EN</b>         |
|                                  |            |                   | rw                |

| Field | Bits | Type | Description  |
|-------|------|------|--|
| RST   | 15   | rwh  | <b>MDIO Slave Hardware Reset</b><br>Reset all hardware modules except for the register settings. This reset acts similar to the hardware reset, but maintains any programming of the control registers and is cleared by HW after Reset is executed.<br>0 <sub>B</sub> <b>OFF</b> Reset is off<br>1 <sub>B</sub> <b>ON</b> Reset is active |
| ADDR  | 8:4  | rw   | <b>SMDIO Address</b><br>This field defined SMDIO address. SMDIO responds to the access of this address.  |
| PREN  | 1    | rw   | <b>SMDIO 32-bit Preamble Enable</b><br>0 <sub>B</sub> <b>DIS</b> Any preamble length can be accepted.<br>1 <sub>B</sub> <b>EN</b> Only 32-bit preamble length can be accepted.   |
| EN    | 0    | rw   | <b>SMDIO Interface Enable</b><br>0 <sub>B</sub> <b>DIS</b> SMDIO Slave interface is disabled.<br>1 <sub>B</sub> <b>EN</b> SMDIO Slave interface is enabled.  |

### MDIO Slave Target Base Address

This register is used to configure MDIO slave target base address

| SMDIO_BADR                             | Offset            | Reset Value       |
|--|-------------------|-------------------|
| MDC Slave Target Base Address Register | F481 <sub>H</sub> | 0000 <sub>H</sub> |
| 15                                     |                   | 8                 |
|  | ADDR              |                   |
|  | rw                |                   |
| 7                                      |                   | 0                 |
|  | ADDR              |                   |
|  | rw                |                   |

| Field | Bits | Type | Description   |
|-------|------|------|---|
| ADDR  | 15:0 | rw   | <p><b>Target Base Address</b></p> <p>It stores the target base address. For MDIO slave access, the address of target register is target base address + 5-bit offset address [in SMDIO REGADDR].</p> <p>This register's SMDIO REGADDR is 1F<sub>H</sub>.</p> |



### 4.1.5 SPI Master Registers

This section provides the registers required for the SPI master interface.

#### SPI Master Interface Configuration

This register is used to configure SPI master interface mode.

| MSPI_CFG   |    | Offset                  | Reset Value             |
|--|----|-------------------------|-------------------------|
| <b>SPI Master Interface Configuration Register</b> |    | <b>F510<sub>H</sub></b> | <b>8019<sub>H</sub></b> |
| 15   | 14 | 13                      | 8                       |
| <b>ADDRMD</b>                                      |    | <b>Res</b>              |                         |
| rw   |    |                         |                         |
| 7  |    |                         | 0                       |
| <b>CLKDIV</b>                                      |    |                         |                         |
| rw   |    |                         |                         |

| Field  | Bits  | Type | Description   |
|--------|-------|------|---|
| ADDRMD | 15:14 | rw   | <b>SPI Master Addressing Mode</b><br>This bit specifies SPI master interface addressing mode.<br>00 <sub>B</sub> <b>9-bit</b> SPI master interface is in 9-bit address mode.<br>01 <sub>B</sub> <b>16-bit</b> SPI master interface is in 16/17-bit address mode.<br>10 <sub>B</sub> <b>24-bit</b> SPI master interface is in 24-bit address mode.<br>11 <sub>B</sub> <b>24H-bit</b> SPI master interface is in 24-bit high speed access mode. |
| CLKDIV | 7:0   | rw   | <b>SPI Clock Divider</b><br>This bit specifies SPI master interface clock divider. SPI clock is system core clock divided by this configuration. Frequency of SPI Clock = $\text{Sys\_clock\_freq}/8/(\text{CLKDIV}+1)$   |

**SPI Master Operating Mode Configuration**

This register is used to configure SPI master interface operating mode.

| <b>MSPI_OP</b>  | <b>Offset</b>           | <b>Reset Value</b>      |
|---|-------------------------|-------------------------|
| <b>SPI Master Operating Mode Configuration Register</b> | <b>F511<sub>H</sub></b> | <b>0000<sub>H</sub></b> |

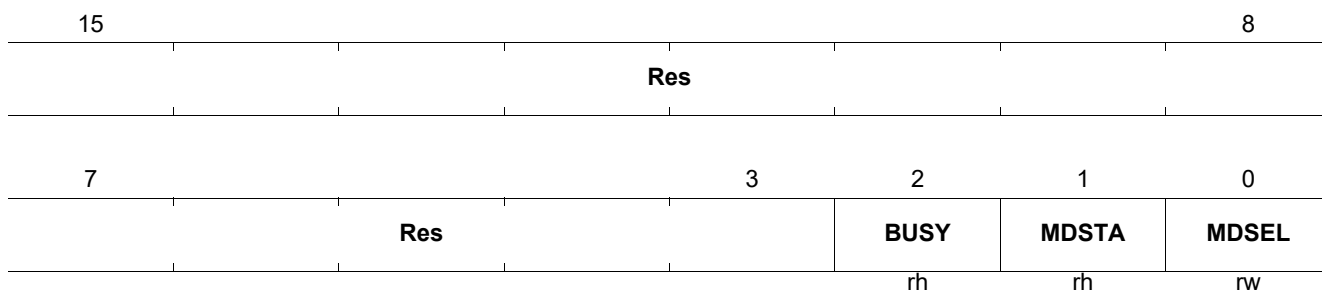

| <b>Field</b> | <b>Bits</b> | <b>Type</b> | <b>Description</b>  |
|--------------|-------------|-------------|---|
| BUSY         | 2           | rh          | <b>SPI Master Transaction Ongoing</b><br>This bit tells SPI master transaction status.<br>0 <sub>B</sub> <b>IDLE</b> There is no ongoing SPI master transaction.<br>1 <sub>B</sub> <b>PEND</b> Pending request of manual mode is acknowledged.  |
| MDSTA        | 1           | rh          | <b>SPI Master Operation Mode Status</b><br>This bit indicates SPI master operation mode status.<br>0 <sub>B</sub> <b>AUTO</b> SPI master is in Auto operation mode.<br>1 <sub>B</sub> <b>MANU</b> SPI master is in manual operation mode.   |
| MDSEL        | 0           | rw          | <b>SPI Master Operation Mode Selection</b><br>This bit specifies SPI manual or auto operation mode selection. The changing of this bit triggers the operation mode change request. Manual mode operation can be started when operation mode status is changed to manual mode.<br>0 <sub>B</sub> <b>AUTO</b> Auto operation mode is selected.<br>1 <sub>B</sub> <b>MANU</b> Manual operation mode is selected. |

**SPI Master Manual Mode Control**

This register is used to control SPI master manual mode transaction.

| MSPI_MANCTRL                            |     | Offset            | Reset Value       |
|---|-----|-------------------|-------------------|
| SPI Master Manual Mode Control Register |     | F512 <sub>H</sub> | 0000 <sub>H</sub> |
| 15                                      |     |                   | 8                 |
| Res                                     |     |                   |                   |
| 7                                       | 4   | 3                 | 2                 |
|   | Res | START             | SIZE              |
|   |     | rwh               | rw                |

| Field | Bits | Type | Description  |
|-------|------|------|--|
| START | 3    | rwh  | <b>SPI Manual Mode Transaction Start Request</b><br>This bit triggers SPI manual mode transaction to start. Writing to '1' to triggers the manual mode transaction. When the transaction is done, this bit is clear by hardware automatically<br>0 <sub>B</sub> <b>NIL</b> There is no ongoing manual mode transaction.<br>1 <sub>B</sub> <b>START</b> Manual mode transaction is started and ongoing. |
| SIZE  | 2:0  | rw   | <b>SPI Manual Mode Transaction Size</b><br>Size of SPI transaction in Bytes (actual size = t_size + 1), i.e. 0: size = 1 Byte, 7: size = 8 Byte  |

### SPI Master Interrupt Status Register

This register is used to hold SPI interrupt status.

| MSPI_ISR                             | Offset            | Reset Value       |
|--------------------------------------|-------------------|-------------------|
| SPI Master Interrupt Status Register | F513 <sub>H</sub> | 0000 <sub>H</sub> |
| 15                                   |                   | 8                 |
|                                      | Res               |                   |
| 7                                    |                   | 0                 |
|                                      | Res               | DONE              |
|                                      |                   | ihsc              |

| Field | Bits | Type | Description  |
|-------|------|------|--|
| DONE  | 0    | lhsc | <b>SPI Manual Operation Transaction Done</b><br>This field holds SPI manual operation mode transaction done interrupt.<br>0 <sub>B</sub> <b>NONE</b> Done interrupt is not triggered.<br>1 <sub>B</sub> <b>DONE</b> Done interrupt is triggered. |

**SPI Master Interrupt Enable Register**

This register is used to specify SPI interrupt enable.

| MSPI_IER                                    | Offset                  | Reset Value             |
|---|-------------------------|-------------------------|
| <b>SPI Master Interrupt Enable Register</b> | <b>F514<sub>H</sub></b> | <b>0000<sub>H</sub></b> |
| 15  |                         | 8                       |
| <b>Res</b>                                  |                         |                         |
| 7   |                         | 0                       |
| <b>Res</b>                                  |                         | <b>DONE</b>             |
| rw  |                         |                         |

| Field | Bits | Type | Description   |
|-------|------|------|---|
| DONE  | 0    | rw   | <b>SPI Access Done</b><br>This field specifies SPI access done interrupt enable<br>0 <sub>B</sub> <b>DIS</b> Access Done interrupt is disabled.<br>1 <sub>B</sub> <b>EN</b> Access Done interrupt is enabled. |

**SPI Master Data In 0/1 Register**

This register is used to store SPI data in byte 0 and 1.

| MSPI_DIN01                             | Offset                  | Reset Value             |
|--|-------------------------|-------------------------|
| <b>SPI Master Data In 0/1 Register</b> | <b>F518<sub>H</sub></b> | <b>0000<sub>H</sub></b> |
| 15                                     |                         | 8                       |
| <b>DIN0</b>                            |                         |                         |
| rh                                     |                         |                         |
| 7                                      |                         | 0                       |
| <b>DIN1</b>                            |                         |                         |
| rh                                     |                         |                         |

| Field | Bits | Type | Description   |
|-------|------|------|---|
| DIN0  | 15:8 | rh   | <b>SPI Data In Byte 0</b><br>This field holds byte 0 (first byte) of the latest read transaction. |
| DIN1  | 7:0  | rh   | <b>SPI Data In Byte 1</b><br>This field holds byte 1 of the latest read transaction.              |

**SPI Master Data In 2/3 Register**

This register is used to store SPI data in byte 2 and 3.

| <b>MSPI_DIN23</b>                      | <b>Offset</b>           | <b>Reset Value</b>      |
|--|-------------------------|-------------------------|
| <b>SPI Master Data In 2/3 Register</b> | <b>F519<sub>H</sub></b> | <b>0000<sub>H</sub></b> |
| 15                                     |                         | 8                       |
|  | <b>DIN2</b>             |                         |
|  | rh                      |                         |
| 7                                      |                         | 0                       |
|  | <b>DIN3</b>             |                         |
|  | rh                      |                         |

| <b>Field</b> | <b>Bits</b> | <b>Type</b> | <b>Description</b>   |
|--------------|-------------|-------------|--|
| DIN2         | 15:8        | rh          | <b>SPI Data In Byte 2</b><br>This field holds byte 2 of the latest read transaction. |
| DIN3         | 7:0         | rh          | <b>SPI Data In Byte 3</b><br>This field holds byte 3 of the latest read transaction. |

**SPI Master Data In 4/5 Register**

This register is used to store SPI data in byte 4 and 5.

| <b>MSPI_DIN45</b>                      | <b>Offset</b>           | <b>Reset Value</b>      |
|--|-------------------------|-------------------------|
| <b>SPI Master Data In 4/5 Register</b> | <b>F51A<sub>H</sub></b> | <b>0000<sub>H</sub></b> |
| 15                                     |                         | 8                       |
|  | <b>DIN4</b>             |                         |
|  | rh                      |                         |
| 7                                      |                         | 0                       |
|  | <b>DIN5</b>             |                         |
|  | rh                      |                         |

| <b>Field</b> | <b>Bits</b> | <b>Type</b> | <b>Description</b>   |
|--------------|-------------|-------------|--|
| DIN4         | 15:8        | rh          | <b>SPI Data In Byte 4</b><br>This field holds byte 4 of the latest read transaction. |
| DIN5         | 7:0         | rh          | <b>SPI Data In Byte 5</b><br>This field holds byte 5 of the latest read transaction. |

**SPI Master Data In 6/7 Register**

This register is used to store SPI data in byte 6 and 7.

| <b>MSPI_DIN67</b>                      | <b>Offset</b>           | <b>Reset Value</b>      |
|--|-------------------------|-------------------------|
| <b>SPI Master Data In 6/7 Register</b> | <b>F51B<sub>H</sub></b> | <b>0000<sub>H</sub></b> |
| 15                                     |                         | 8                       |
|  | <b>DIN6</b>             |                         |
|  | rh                      |                         |
| 7                                      |                         | 0                       |
|  | <b>DIN7</b>             |                         |
|  | rh                      |                         |

| <b>Field</b> | <b>Bits</b> | <b>Type</b> | <b>Description</b>   |
|--------------|-------------|-------------|--|
| DIN6         | 15:8        | rh          | <b>SPI Data In Byte 6</b><br>This field holds byte 6 of the latest read transaction. |
| DIN7         | 7:0         | rh          | <b>SPI Data In Byte 7</b><br>This field holds byte 7 of the latest read transaction. |

**SPI Master Data Out 0/1 Register**

This register is used to store SPI data out byte 0 and 1.

| <b>MSPI_DOUT01</b>                      | <b>Offset</b>           | <b>Reset Value</b>      |
|---|-------------------------|-------------------------|
| <b>SPI Master Data Out 0/1 Register</b> | <b>F51C<sub>H</sub></b> | <b>0000<sub>H</sub></b> |
| 15                                      |                         | 8                       |
|   | <b>DOUT0</b>            |                         |
|   | rw                      |                         |
| 7                                       |                         | 0                       |
|   | <b>DOUT1</b>            |                         |
|   | rw                      |                         |

| <b>Field</b> | <b>Bits</b> | <b>Type</b> | <b>Description</b>  |
|--------------|-------------|-------------|---|
| DOUT0        | 15:8        | rw          | <b>SPI Data Out Byte 0</b><br>This field holds byte 0 (first byte) of the latest write transaction. |
| DOUT1        | 7:0         | rw          | <b>SPI Data Out Byte 1</b><br>This field holds byte 1 of the latest write transaction.              |

**SPI Master Data Out 2/3 Register**

This register is used to store SPI data out byte 2 and 3.

| <b>MSPI_DOUT23</b>                      | <b>Offset</b>           | <b>Reset Value</b>      |
|---|-------------------------|-------------------------|
| <b>SPI Master Data Out 2/3 Register</b> | <b>F51D<sub>H</sub></b> | <b>0000<sub>H</sub></b> |
| 15                                      |                         | 8                       |
| <b>DOUT2</b>                            |                         |                         |
| rw                                      |                         |                         |
| 7                                       |                         | 0                       |
| <b>DOUT3</b>                            |                         |                         |
| rw                                      |                         |                         |

| <b>Field</b> | <b>Bits</b> | <b>Type</b> | <b>Description</b>   |
|--------------|-------------|-------------|--|
| DOUT2        | 15:8        | rw          | <b>SPI Data Out Byte 2</b><br>This field holds byte 2 of the latest write transaction. |
| DOUT3        | 7:0         | rw          | <b>SPI Data Out Byte 3</b><br>This field holds byte 3 of the latest write transaction. |

**SPI Master Data Out 4/5 Register**

This register is used to store SPI data out byte 4 and 5.

| <b>MSPI_DOUT45</b>                      | <b>Offset</b>           | <b>Reset Value</b>      |
|---|-------------------------|-------------------------|
| <b>SPI Master Data Out 4/5 Register</b> | <b>F51E<sub>H</sub></b> | <b>0000<sub>H</sub></b> |
| 15                                      |                         | 8                       |
| <b>DOUT4</b>                            |                         |                         |
| rw                                      |                         |                         |
| 7                                       |                         | 0                       |
| <b>DOUT5</b>                            |                         |                         |
| rw                                      |                         |                         |

| <b>Field</b> | <b>Bits</b> | <b>Type</b> | <b>Description</b>   |
|--------------|-------------|-------------|--|
| DOUT4        | 15:8        | rw          | <b>SPI Data Out Byte 4</b><br>This field holds byte 4 of the latest write transaction. |
| DOUT5        | 7:0         | rw          | <b>SPI Data Out Byte 5</b><br>This field holds byte 5 of the latest write transaction. |



**SPI Master Data Out 6/7 Register**

This register is used to store SPI data out byte 6 and 7.

| <b>MSPI_DOUT67</b>                      | <b>Offset</b>           | <b>Reset Value</b>      |
|---|-------------------------|-------------------------|
| <b>SPI Master Data Out 6/7 Register</b> | <b>F51F<sub>H</sub></b> | <b>0000<sub>H</sub></b> |
| 15                                      |                         | 8                       |
| <b>DOUT6</b>                            |                         |                         |
| rw                                      |                         |                         |
| 7                                       |                         | 0                       |
| <b>DOUT7</b>                            |                         |                         |
| rw                                      |                         |                         |

| <b>Field</b> | <b>Bits</b> | <b>Type</b> | <b>Description</b>   |
|--------------|-------------|-------------|--|
| DOUT6        | 15:8        | rw          | <b>SPI Data Out Byte 6</b><br>This field holds byte 6 of the latest write transaction. |
| DOUT7        | 7:0         | rw          | <b>SPI Data Out Byte 7</b><br>This field holds byte 7 of the latest write transaction. |

### 4.1.6 SPI Slave Registers

This section provides the registers required for the SPI slave interface.

#### SPI Slave Configuration Register

This register is used for SPI Slave Interface Configuration.

| SSPI_CFG                         |                 | Offset            |    | Reset Value       |           |
|----------------------------------|-----------------|-------------------|----|-------------------|-----------|
| SPI Slave Configuration Register |                 | F580 <sub>H</sub> |    | 0200 <sub>H</sub> |           |
| 15                               | 14              | 13                | 10 | 9                 | 8         |
| <b>SDOEGSEL</b>                  | <b>SDIEGSEL</b> | <b>Res</b>        |    | <b>REFCYC</b>     |           |
| rw                               | rw              |                   |    | rw                |           |
| 7                                |                 |                   |    | 1                 | 0         |
| <b>DRVDLY</b>                    |                 |                   |    |                   | <b>EN</b> |
|                                  |                 |                   |    |                   | rw        |

| Field    | Bits | Type | Description  |
|----------|------|------|--|
| SDOEGSEL | 15   | rw   | <b>SDO Edge Select</b><br>This field selects the edge with which a SDO is driven out. For example, when the master expects a rising edge, the driving must be at the rising edge.<br>0 <sub>B</sub> <b>FALL</b> SDO is driven at falling edge.<br>1 <sub>B</sub> <b>RISE</b> SDO is driven at rising edge.         |
| SDIEGSEL | 14   | rw   | <b>SDI Edge Select</b><br>This field selects the edge with which a SDI is sampled reliably (e.g. when master drives with rising edge, sampling must be set to falling, VERY IMPORTANT).<br>0 <sub>B</sub> <b>FALL</b> SDI is sampled at falling edge.<br>1 <sub>B</sub> <b>RISE</b> SDI is sampled at rising edge. |
| REFCYC   | 9:8  | rw   | <b>SPI Slave Bus Reference Cycle</b><br>It specifies SDO output cycle adjustment, default value is 2, as to allow for adjustments up to 2 SCK clock cycles earlier.  |
| DRVDLY   | 7:1  | rw   | <b>SPI Slave Bus Driver Delay</b><br>It specifies delay given in number of core clock cycles.<br><i>Note: Values 0 and 1 correspond to about delay of 4 core clock cycles as seen from PAD.</i>  |
| EN       | 0    | rw   | <b>SPI Slave Interface Enable</b><br>0 <sub>B</sub> <b>DIS</b> SPI Slave interface is disabled.<br>1 <sub>B</sub> <b>EN</b> SPI Slave interface is enabled.  |

### 4.1.7 UART Registers

This section provides the registers required for the UART interface.

#### UART Configuration Register

This register is used for UART Configuration.

| UART_CFG                    | Offset            | Reset Value       |
|-----------------------------|-------------------|-------------------|
| UART Configuration Register | F680 <sub>H</sub> | 0001 <sub>H</sub> |
| 15                          | 10                | 9                 |
| Res                         |                   | LFDIS             |
|                             |                   | CRDIS             |
|                             |                   | rw                |
|                             |                   | rw                |
| 7                           | 4                 | 3                 |
| STOP                        |                   | Res               |
|                             |                   | PAREN             |
|                             |                   | EN                |
| rw                          |                   | rw                |
|                             |                   | rw                |

| Field | Bits | Type | Description  |
|-------|------|------|--|
| LFDIS | 9    | rw   | <b>LF As Enter Disable</b><br>0 <sub>B</sub> <b>EN</b> LF as “echoed enter” is enabled.<br>1 <sub>B</sub> <b>DIS</b> LF as “echoed enter” is disabled. |
| CRDIS | 8    | rw   | <b>CR As Enter Disable</b><br>0 <sub>B</sub> <b>EN</b> CR as “echoed enter” is enabled.<br>1 <sub>B</sub> <b>DIS</b> CR as “echoed enter” is disabled. |
| STOP  | 7:4  | rw   | <b>Additional Stop Bits</b><br>The number of additional stop bits. The number of stop bits is 1 plus additional stop bits.                             |
| PAREN | 1    | rw   | <b>UART Parity Enable</b><br>0 <sub>B</sub> <b>DIS</b> Parity is disabled.<br>1 <sub>B</sub> <b>EN</b> Parity is enabled.                              |
| EN    | 0    | rw   | <b>UART Interface Enable</b><br>0 <sub>B</sub> <b>DIS</b> UART interface is disabled.<br>1 <sub>B</sub> <b>EN</b> UART interface is enabled.           |

### UART Baud Rate Register

This register is used for UART Baud Rate Configuration.

| UART_BD                 | Offset            | Reset Value       |
|-------------------------|-------------------|-------------------|
| UART Baud Rate Register | F681 <sub>H</sub> | 0B71 <sub>H</sub> |
| 15                      |                   | 8                 |
|                         | <b>BD</b>         |                   |
|                         | rw                |                   |
| 7                       |                   | 0                 |
|                         | <b>BD</b>         |                   |
|                         | rw                |                   |

| Field | Bits | Type | Description   |
|-------|------|------|---|
| BD    | 15:0 | rw   | <b>Baud Rate Divider</b><br>This field must be configured: round down 250M/baud rate to an integer. |

**UART Baud Rate Fractional Divider Register**

This register is used for UART Baud Rate Fractional Divider Configuration.

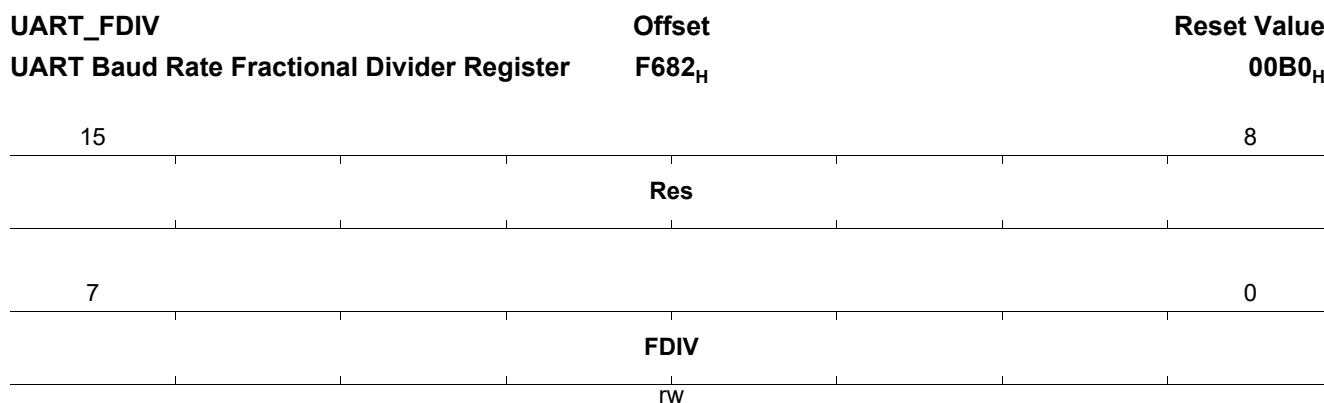

| Field | Bits | Type | Description   |
|-------|------|------|---|
| FDIV  | 7:0  | rw   | <b>Baud Rate Fractional Divider</b><br>The baud rate fractional divider is configured to: round up $256 * (250M / \text{baud rate} - BD)$ to an integer |

### UART PROMPT Register

This register is used for UART Prompt.

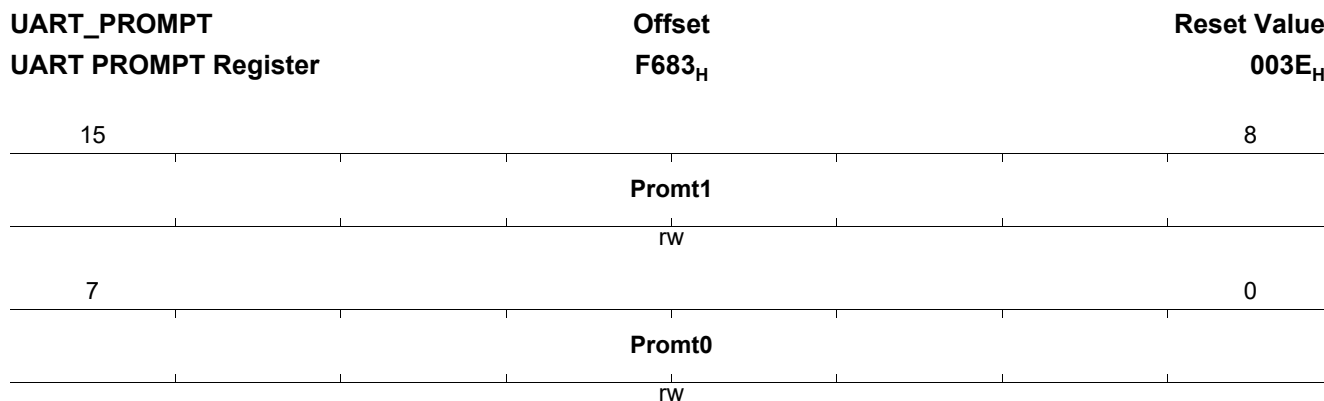

| Field   | Bits | Type | Description   |
|---------|------|------|---|
| Prompt1 | 15:8 | rw   | <b>Second Prompt Character</b><br>When this field is 0, then second prompt character is disabled. |
| Prompt0 | 7:0  | rw   | <b>First Prompt Character</b>   |

**UART Error Counter Register**

This register is used for UART Error Counter Register.

| UART_ERRCNT                 | Offset            | Reset Value       |
|-----------------------------|-------------------|-------------------|
| UART Error Counter Register | F684 <sub>H</sub> | 0000 <sub>H</sub> |
| 15                          |                   | 8                 |
|                             | CNT               |                   |
|                             | rh                |                   |
| 7                           |                   | 0                 |
|                             | CNT               |                   |
|                             | rh                |                   |

| Field | Bits | Type | Description                           |
|-------|------|------|---------------------------------------|
| CNT   | 15:0 | rh   | <b>Error Counter</b><br>Error Counter |

**4.1.8 Clock Generation Unit Registers**

This section describes all registers in CGU module.

**Top Level RO PLL Configuration 0 Register**

It configures the top level RO PLL. This register cannot be reset by global software reset and module software reset.

| ROPLL_CFG0                      | Offset            | Reset Value       |
|---------------------------------|-------------------|-------------------|
| RO PLL Configuration 0 Register | F980 <sub>H</sub> | 0141 <sub>H</sub> |
| 15                              |                   | 9                 |
|                                 | PLL_K             | 8                 |
|                                 | rw                | PLL_N             |
|                                 |                   | rw                |
| 7                               |                   | 2                 |
|                                 | PLL_N             | 1                 |
|                                 |                   | PLL_L             |
|                                 |                   | PLL_RST           |
|                                 | rw                | rh                |
|                                 |                   | rw                |

| Field | Bits | Type | Description  |
|-------|------|------|--|
| PLL_K | 15:9 | rw   | <b>PLL Fractional K Divider 6:0</b><br>PLL fractional K divider configuration. |
| PLL_N | 8:2  | rw   | <b>PLL N Divider</b><br>PLL N divider configuration.                           |

**Registers**

| Field   | Bits | Type | Description   |
|---------|------|------|---|
| PLL_L   | 1    | rh   | <b>PLL Lock Status</b><br>PLL lock/unlock status information.<br>0 <sub>B</sub> <b>DISABLE</b> Disable PLL is not locked (default after reset).<br>1 <sub>B</sub> <b>ENABLE</b> Enable PLL is locked. |
| PLL_RST | 0    | rw   | <b>PLL Reset</b><br>PLL reset control.<br>0 <sub>B</sub> <b>RST</b> Reset PLL.<br>1 <sub>B</sub> <b>NORST</b> No reset PLL.   |

**Top Level RO PLL Configuration 1 Register**

It configures the RO PLL. This register cannot be reset by global software reset and module software reset.

| ROPLL_CFG1                      |        | Offset            | Reset Value       |
|---------------------------------|--------|-------------------|-------------------|
| RO PLL Configuration 1 Register |        | F984 <sub>H</sub> | 0000 <sub>H</sub> |
| 15                              | 14     | 13                | 8                 |
| PLL_BUFOUT                      | PLL_BP |                   | PLL_K             |
| rw                              | rw     |                   | rw                |
| 7                               |        |                   | 0                 |
|                                 |        | PLL_K             |                   |
|                                 |        | rw                |                   |

| Field      | Bits | Type | Description  |
|------------|------|------|--|
| PLL_BUFOUT | 15   | rw   | <b>PLL CML input buffer</b><br>PLL CML input buffered output enable. Disabled by default, this enable the CML clock buffer for CLKREF and supports buffered clock cascade on chip<br>0 <sub>B</sub> <b>DSIABLE</b> Disable CML input buffered output disabled<br>1 <sub>B</sub> <b>ENABLE</b> Enable CML input buffered output enabled |
| PLL_BP     | 14   | rw   | <b>PLL Bypass</b><br>PLL bypass enable.<br>0 <sub>B</sub> <b>DISABLE</b> Disable PLL is enabled (default).<br>1 <sub>B</sub> <b>ENABLE</b> Enable PLL is bypassed.   |
| PLL_K      | 13:0 | rw   | <b>PLL0 Fractional K Divider 20 to 7</b><br>PLL fractional K divider configuration.  |

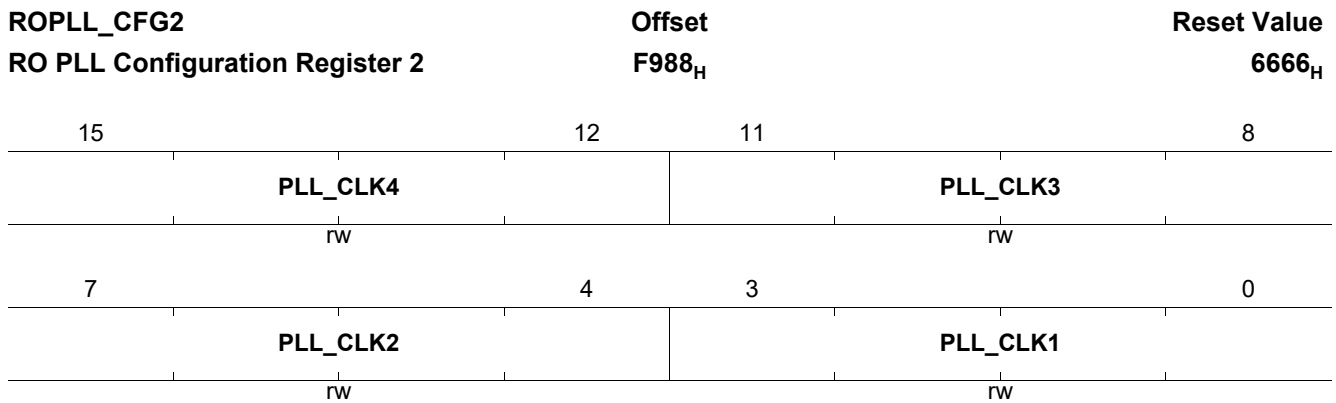

**Top Level RO PLL Configuration 2 Register**

| Field    | Bits  | Type | Description  |
|----------|-------|------|--|
| PLL_CLK4 | 15:12 | rw   | <b>PLL Clock Output 4</b><br>PLL Clock output 4 configuration.<br>0000 <sub>B</sub> <b>GND</b> Ground output clock is disabled<br>0001 <sub>B</sub> <b>DIV2</b> Divide by 2 of VCO 2 GHz<br>0010 <sub>B</sub> <b>DIV3</b> Divide by 3 of VCO 2 GHz<br>0011 <sub>B</sub> <b>DIV4</b> Divide by 4 of VCO 2 GHz<br>0100 <sub>B</sub> <b>DIV5</b> Divide by 5 of VCO 2 GHz<br>0101 <sub>B</sub> <b>DIV6</b> Divide by 6 of VCO 2 GHz<br>0110 <sub>B</sub> <b>DIV8</b> Divide by 8 of VCO 2 GHz<br>0111 <sub>B</sub> <b>DIV10</b> Divide by 10 of VCO 2 GHz<br>1000 <sub>B</sub> <b>DIV12</b> Divide by 12 of VCO 2 GHz<br>1001 <sub>B</sub> <b>DIV16</b> Divide by 16 of VCO 2 GHz<br>1010 <sub>B</sub> <b>DIV20</b> Divide by 20 of VCO 2 GHz<br>1011 <sub>B</sub> <b>DIV24</b> Divide by 24 of VCO 2 GHz<br>1100 <sub>B</sub> <b>DIV32</b> Divide by 32 of VCO 2 GHz<br>1101 <sub>B</sub> <b>DIV40</b> Divide by 40 of VCO 2 GHz<br>1110 <sub>B</sub> <b>DIV48</b> Divide by 48 of VCO 2 GHz<br>1111 <sub>B</sub> <b>DIV64</b> Divide by 64 of VCO 2 GHz |

| Field    | Bits | Type | Description (cont'd)   |
|----------|------|------|--|
| PLL_CLK3 | 11:8 | rw   | <b>PLL Clock Output 3</b><br>PLL Clock output 3 configuration.<br>0000 <sub>B</sub> <b>GND</b> Ground output clock is disabled<br>0001 <sub>B</sub> <b>DIV2</b> Divide by 2 of VCO 2 GHz<br>0010 <sub>B</sub> <b>DIV3</b> Divide by 3 of VCO 2 GHz<br>0011 <sub>B</sub> <b>DIV4</b> Divide by 4 of VCO 2 GHz<br>0100 <sub>B</sub> <b>DIV5</b> Divide by 5 of VCO 2 GHz<br>0101 <sub>B</sub> <b>DIV6</b> Divide by 6 of VCO 2 GHz<br>0110 <sub>B</sub> <b>DIV8</b> Divide by 8 of VCO 2 GHz<br>0111 <sub>B</sub> <b>DIV10</b> Divide by 10 of VCO 2 GHz<br>1000 <sub>B</sub> <b>DIV12</b> Divide by 12 of VCO 2 GHz<br>1001 <sub>B</sub> <b>DIV16</b> Divide by 16 of VCO 2 GHz<br>1010 <sub>B</sub> <b>DIV20</b> Divide by 20 of VCO 2 GHz<br>1011 <sub>B</sub> <b>DIV24</b> Divide by 24 of VCO 2 GHz<br>1100 <sub>B</sub> <b>DIV32</b> Divide by 32 of VCO 2 GHz<br>1101 <sub>B</sub> <b>DIV40</b> Divide by 40 of VCO 2 GHz<br>1110 <sub>B</sub> <b>DIV48</b> Divide by 48 of VCO 2 GHz<br>1111 <sub>B</sub> <b>DIV64</b> Divide by 64 of VCO 2 GHz |
| PLL_CLK2 | 7:4  | rw   | <b>PLL Clock Output 2</b><br>PLL Clock output 2 configuration.<br>0000 <sub>B</sub> <b>GND</b> Ground output clock is disabled<br>0001 <sub>B</sub> <b>DIV2</b> Divide by 2 of VCO 2 GHz<br>0010 <sub>B</sub> <b>DIV3</b> Divide by 3 of VCO 2 GHz<br>0011 <sub>B</sub> <b>DIV4</b> Divide by 4 of VCO 2 GHz<br>0100 <sub>B</sub> <b>DIV5</b> Divide by 5 of VCO 2 GHz<br>0101 <sub>B</sub> <b>DIV6</b> Divide by 6 of VCO 2 GHz<br>0110 <sub>B</sub> <b>DIV8</b> Divide by 8 of VCO 2 GHz<br>0111 <sub>B</sub> <b>DIV10</b> Divide by 10 of VCO 2 GHz<br>1000 <sub>B</sub> <b>DIV12</b> Divide by 12 of VCO 2 GHz<br>1001 <sub>B</sub> <b>DIV16</b> Divide by 16 of VCO 2 GHz<br>1010 <sub>B</sub> <b>DIV20</b> Divide by 20 of VCO 2 GHz<br>1011 <sub>B</sub> <b>DIV24</b> Divide by 24 of VCO 2 GHz<br>1100 <sub>B</sub> <b>DIV32</b> Divide by 32 of VCO 2 GHz<br>1101 <sub>B</sub> <b>DIV40</b> Divide by 40 of VCO 2 GHz<br>1110 <sub>B</sub> <b>DIV48</b> Divide by 48 of VCO 2 GHz<br>1111 <sub>B</sub> <b>DIV64</b> Divide by 64 of VCO 2 GHz |

| Field    | Bits | Type | Description (cont'd)   |
|----------|------|------|--|
| PLL_CLK1 | 3:0  | rw   | <b>PLL Clock Output 1</b><br>PLL Clock output 1 configuration.<br>0000 <sub>B</sub> <b>GND</b> Ground output clock is disabled<br>0001 <sub>B</sub> <b>DIV2</b> Divide by 2 of VCO 2 GHz 1000 MHz<br>0010 <sub>B</sub> <b>DIV3</b> Divide by 3 of VCO 2 GHz 666.66 MHz<br>0011 <sub>B</sub> <b>DIV4</b> Divide by 4 of VCO 2 GHz 500 MHz<br>0100 <sub>B</sub> <b>DIV5</b> Divide by 5 of VCO 2 GHz 400 MHz<br>0101 <sub>B</sub> <b>DIV6</b> Divide by 6 of VCO 2 GHz 333.33 MHz<br>0110 <sub>B</sub> <b>DIV8</b> Divide by 8 of VCO 2 GHz 250 MHz<br>0111 <sub>B</sub> <b>DIV10</b> Divide by 10 of VCO 2 GHz 200 MHz<br>1000 <sub>B</sub> <b>DIV12</b> Divide by 12 of VCO 2 GHz 166.66 MHz<br>1001 <sub>B</sub> <b>DIV16</b> Divide by 16 of VCO 2 GHz 125 MHz<br>1010 <sub>B</sub> <b>DIV20</b> Divide by 20 of VCO 2 GHz 100 MHz<br>1011 <sub>B</sub> <b>DIV24</b> Divide by 24 of VCO 2 GHz 83.33 MHz<br>1100 <sub>B</sub> <b>DIV32</b> Divide by 32 of VCO 2 GHz 62.5 MHz<br>1101 <sub>B</sub> <b>DIV40</b> Divide by 40 of VCO 2 GHz 50 MHz<br>1110 <sub>B</sub> <b>DIV48</b> Divide by 48 of VCO 2 GHz 41.67 MHz<br>1111 <sub>B</sub> <b>DIV64</b> Divide by 64 of VCO 2 GHz 31.25 MHz |

**Top Level RO PLL Configuration 3 Register**

| ROPLL_CFG3                      |                 | Offset            |                   | Reset Value       |                 |
|---------------------------------|-----------------|-------------------|-------------------|-------------------|-----------------|
| RO PLL Configuration Register 3 |                 | F98C <sub>H</sub> |                   | 0178 <sub>H</sub> |                 |
| 15                              | 14              | 13                | 12                | 9                 | 8               |
| <b>PLL_BW</b>                   |                 | <b>Res</b>        | <b>PLL_INVCLK</b> |                   | <b>PLL_SSC</b>  |
| rw                              |                 |                   | rw                |                   | rw              |
| 7                               | 6               | 5                 | 4                 | 3                 | 2               |
| <b>PLL_N_MODE</b>               | <b>PLL_OPD5</b> | <b>PLL_OPD4</b>   | <b>PLL_OPD3</b>   | <b>PLL_OPD2</b>   | <b>PLL_OPD1</b> |
| rw                              | rw              | rw                | rw                | rw                | rw              |

| Field      | Bits  | Type | Description   |
|------------|-------|------|---|
| PLL_BW     | 15:14 | rw   | <b>PLL Bandwidth Select</b><br>PLL Bandwidth configuration.   |
| PLL_INVCLK | 12:9  | rw   | <b>PLL Invert Clock Enable</b><br>When '1' select the respective CLK1, CLK2, CLK3, CLK4 output buffer to be inverted as the output.<br>0 <sub>B</sub> <b>DIS</b> Inverter not enabled.<br>1 <sub>B</sub> <b>EN</b> Inverter enabled |
| PLL_SSC    | 8     | rw   | <b>PLL Spread Spectrum Mode</b><br>Configures the PLL N mode.<br>0 <sub>B</sub> <b>ENABLE</b> Enable Fractional input and SSC code is used.<br>1 <sub>B</sub> <b>DISABLE</b> Disable Ignores fractional and SS code                 |
| PLL_N_MODE | 7     | rw   | <b>Integer N Mode Enable</b><br>Integer-N Mode. When high, it ignores the fractional code and SSC code.<br>0 <sub>B</sub> <b>FRAC</b> Fractional Mode with SSC<br>1 <sub>B</sub> <b>INT</b> Integer-N Mode only                     |
| PLL_OPD5   | 6     | rw   | <b>PLL CLK5 Output Buffer Power Down</b><br>Output Clock buffer power down for CLK5<br>0 <sub>B</sub> <b>NORMAL</b> Buffer is active<br>1 <sub>B</sub> <b>PD</b> Buffer is power down   |
| PLL_OPD4   | 5     | rw   | <b>PLL CLK4 Output Buffer Power Down</b><br>Output Clock buffer power down for CLK4<br>0 <sub>B</sub> <b>NORMAL</b> Buffer is active<br>1 <sub>B</sub> <b>PD</b> Buffer is power down   |
| PLL_OPD3   | 4     | rw   | <b>PLL CLK3 Output Buffer Power Down</b><br>Output Clock buffer power down for CLK3<br>0 <sub>B</sub> <b>NORMAL</b> Buffer is active<br>1 <sub>B</sub> <b>PD</b> Buffer is power down   |

| Field    | Bits | Type | Description (cont'd)   |
|----------|------|------|--|
| PLL_OPD2 | 3    | rw   | <b>PLL CLK2 Output Buffer Power Down</b><br>Output Clock buffer power down for CLK2<br>0 <sub>B</sub> <b>NORMAL</b> Buffer is active<br>1 <sub>B</sub> <b>PD</b> Buffer is power down  |
| PLL_OPD1 | 2    | rw   | <b>PLL CLK1 Output Buffer Power Down</b><br>Output Clock buffer power down for CLK1<br>0 <sub>B</sub> <b>NORMAL</b> Buffer is active<br>1 <sub>B</sub> <b>PD</b> Buffer is power down  |
| PLL_CLK5 | 1:0  | rw   | <b>PLL CML CLK5 Output Buffer Frequency Selection</b><br>PLL CLK5 CML output freq select<br>00 <sub>B</sub> <b>DIV4</b> VCO Clock divide by 4<br>01 <sub>B</sub> <b>DIV6</b> VCO Clock divide by 6<br>10 <sub>B</sub> <b>DIV8</b> VCO Clock divide by 8<br>11 <sub>B</sub> <b>DIV12</b> VCO Clock divide by 12 |

**Top Level RO PLL Miscellaneous Control Register**

Not specified.

| ROPLL_MISC                            |              | Offset            |             | Reset Value       |               |             |                |
|---------------------------------------|--------------|-------------------|-------------|-------------------|---------------|-------------|----------------|
| RO PLL Miscellaneous Control Register |              | F990 <sub>H</sub> |             | 0022 <sub>H</sub> |               |             |                |
| 15                                    | 14           | 13                | 12          | 11                | 10            | 9           | 8              |
| <b>PSOVR</b>                          | <b>UNLCK</b> | <b>FORCE</b>      | <b>VEXT</b> | <b>EXTREF</b>     | <b>LCKOVR</b> | <b>IPOK</b> | <b>IOPFSEL</b> |
| rw                                    | ihsc         | rwh               | rw          | rw                | rw            | rw          | rw             |
| 7                                     | 6            | 5                 | 4           | 3                 | 2             | 0           |                |
| <b>INKSEL</b>                         | <b>FPUP</b>  | <b>CLKSEL</b>     |             | <b>MODE</b>       | <b>MPROG</b>  |             |                |
| rw                                    | rw           | rw                |             | rw                | rw            |             |                |

| Field | Bits | Type | Description  |
|-------|------|------|--|
| PSOVR | 15   | rw   | <b>Pin-Strap Overwrite</b><br>When PSOVR='1' we can choose to overwrite the pin-strapped values (MODE, CLKSEL[1:0], INKSEL) with the content of this register.   |
| UNLCK | 14   | ihsc | <b>Sticky Bit for Unlock Status</b><br>This is a sticky bit status to detect whether the PLL was ever unlock and then relock again. Write 1 to clear.  |
| FORCE | 13   | rwh  | <b>Force Latching of Shadow Registers</b><br>By default, all changes in the PDI registers must not take effect until the next SRSTN. For debug purpose, this bit = '1' enable the user to force the latching without using the SRSTN. The changes can take immediate effect. This bit has a self-clearing behaviour to be implemented behind the rwh register type |

| Field   | Bits | Type | Description  |
|---------|------|------|--|
| VEXT    | 12   | rw   | <b>PLL Output Buffer Power Supply</b><br>PLL output buffer supply select signal - Selects between external 1.1 V supply, or internal Regulator supply to drive the output buffers.<br><b>Constants</b><br>0 <sub>B</sub> <b>INT</b> Use Internally generated 1.1 V supply<br>1 <sub>B</sub> <b>EXT</b> Use Externally generated 1.1 V supply   |
| EXTREF  | 11   | rw   | <b>Select External Reference Current</b><br>Select whether we use external Reference Current or the internally generated one.<br>0 <sub>B</sub> <b>INT</b> Use Internally generated REFERENCE BIASING current<br>1 <sub>B</sub> <b>EXT</b> Use Externally generated REFERENCE BIASING current  |
| LCKOVR  | 10   | rw   | <b>PLL Lock Overwrite</b><br>When set to '1' force the ROPLL to assert lock state regardless of the lock detection status.   |
| IPOK    | 9    | rw   | <b>Internal POK Override</b><br>Internal POK Override. This is for debug purpose and force the internal check of Power OK for 1V1 internal LDO power supply generation<br>0 <sub>B</sub> <b>ENABLE</b> Internal check for Power OK state of the LDO<br>1 <sub>B</sub> <b>OVR</b> Internal Power OK module disabled   |
| IOPFSEL | 8    | rw   | <b>PLL Internal Digital Allocates Default Output Frequencies</b><br>Selects if PLL internal digital allocates the default output frequencies. When high, the ropll_op_freq_sel_clk1-4 pins are ignored.<br><b>Constants</b><br>0 <sub>B</sub> <b>EXT</b> PDI selected output frequencies are used for CLK1-CLK4<br>1 <sub>B</sub> <b>INT</b> Internal LUT used for the CLK1-CLK4 frequency selection |
| INKSEL  | 7    | rw   | <b>PLL Internal Mapped N,K or Based on PLL_CFG0/1 N,K</b><br>Selects the values of divider (int, frac) from the internal table lookup. When high, ignores the values of PLL_CFG1.K, PLL_CFG0.K, PLL_CFG1.N bits. Effective only when PSOVR=1. Otherwise according to pin-strap PS_XTAL.  |
| FPUP    | 6    | rw   | <b>Force Power Up of All Divider Chains</b><br>Force Power up of all Divider chains. For debug purpose only<br>0 <sub>B</sub> <b>NORMAL</b> Power up the divider chains according to mode select LUT<br>1 <sub>B</sub> <b>FORCE</b> All divider chain output are forced to power up  |
| CLKSEL  | 5:4  | rw   | <b>PLL Input Clock Select</b><br>PLL input clock select - 25/36/125/40 MHz. Effective only when PSOVR=1. Otherwise according to pin-strap PS_XTAL.<br>00 <sub>B</sub> <b>XTAL36</b> RefCLK is 36 MHz<br>01 <sub>B</sub> <b>XTAL40</b> RefCLK is 40 MHz<br>10 <sub>B</sub> <b>XTAL25</b> RefCLK is 25 MHz<br>11 <sub>B</sub> <b>XTAL125</b> RefCLK is 125 MHz   |
| MODE    | 3    | rw   | <b>Selects CML/CMOS input Clock</b><br>PLL input mode select - CML/CMOS. Effective only when PSOVR=1. Otherwise always '0'.<br>0 <sub>B</sub> <b>CML</b> CML differential input clock selected<br>1 <sub>B</sub> <b>CMOS</b> CMOS differential input clock selected  |

**Registers**

| Field | Bits | Type | Description   |
|-------|------|------|---|
| MPROG | 2:0  | rw   | <b>PLL Mode Selection</b><br>PLL mode selection.<br>000 <sub>B</sub> <b>TM</b> Test Mode<br>001 <sub>B</sub> <b>PLL0A</b> GRX application, PLL0A mode<br>010 <sub>B</sub> <b>PLL0B</b> GRX application, PLL0B mode<br>011 <sub>B</sub> <b>PLL1</b> GRX application, PLL1 mode<br>100 <sub>B</sub> <b>GPHY</b> GPHY ROPLL mode<br>101 <sub>B</sub> <b>WLAN WAVE</b> application mode |

**GPC0 Configuration Register**

It configures general purpose clock 0.

| GPC0_CONF                   | Offset            | Reset Value       |
|-----------------------------|-------------------|-------------------|
| GPC0 Configuration Register | F948 <sub>H</sub> | 0007 <sub>H</sub> |
| 15                          |                   | 8                 |
| Res                         |                   |                   |
| 7                           | 3                 | 2                 |
|                             |                   | 0                 |
|                             | Res               | SEL               |
|                             |                   | rw                |

| Field | Bits | Type | Description  |
|-------|------|------|--|
| SEL   | 2:0  | rw   | <b>GPC0 Output Clock Selection</b><br>This is to select output clock source.<br>101 <sub>B</sub> <b>UCCLK</b> 1/4 of system clock.<br>110 <sub>B</sub> <b>XO</b> XO output.<br>111 <sub>B</sub> <b>CLK250</b> The divided clock of CLK250. |

**Similar Registers**

The following registers are identical to the Register **GPC0\_CONF** defined above.

**Table 55 Similar Registers**

| Register Short Name | Register Long Name          | Offset Address    | Page Number |
|---------------------|-----------------------------|-------------------|-------------|
| GPC1_CONF           | GPC1 Configuration Register | F94C <sub>H</sub> |             |

**SYSCLK Configuration Register**

It configures sys clock divider.

| SYSCLK_CONF<br>SYCCLK Configuration Register | Offset<br>F950 <sub>H</sub> | Reset Value<br>0004 <sub>H</sub> |
|--|-----------------------------|----------------------------------|
| 15   | Res                         | 8                                |
| 7  | CLK250_DIV                  | 0                                |
|  | rw                          |                                  |

| Field      | Bits | Type | Description  |
|------------|------|------|--|
| CLK250_DIV | 7:0  | rw   | <b>CLK250_LC Clock Divider Selection</b><br>When CLK250 is selected for GPC output, the CLK250 is divided before feeding to GPC. The divider is $2^{*(CLK250\_DIV+1)}$ . |



**SGMII Configuration Register**

It configures SGMII PLL and macro.

| SGMII_CONF                          | Offset                  | Reset Value             |            |            |     |           |    |
|-------------------------------------|-------------------------|-------------------------|------------|------------|-----|-----------|----|
| <b>SGMII Configuration Register</b> | <b>F954<sub>H</sub></b> | <b>0000<sub>H</sub></b> |            |            |     |           |    |
| 15                                  |                         | 8                       |            |            |     |           |    |
| Res                                 |                         |                         |            |            |     |           |    |
| 7                                   | 6                       | 5                       | 4          | 3          | 2   | 1         | 0  |
| Res                                 | UNLOCK                  | UNSYNC                  | SGMII_LOCK | SGMII_SYNC | Res | SGMII_DIS |    |
|                                     | ihsc                    | rh                      | rh         | rh         |     |           | rw |

| Field      | Bits | Type | Description   |
|------------|------|------|---|
| UNLOCK     | 6    | ihsc | <b>SGMII PLL Unlock Stick Bit</b><br>This is a sticky bit status to detect whether the PLL was ever unlock and then relock again. Write 1 to clear.<br>0 <sub>B</sub> <b>LOCKED</b> PLL is locked.<br>1 <sub>B</sub> <b>UNLOCKED</b> PLL is unlocked.   |
| UNSYNC     | 5    | rh   | <b>SGMII PMD/PMA Ready</b><br>This is stick bit status to detect whether SGMII PMD/PMA is un-synced. Write 1 to clear.<br>0 <sub>B</sub> <b>SYNCED</b> PMD/PMA is synced.<br>1 <sub>B</sub> <b>UNSYNC</b> PMA/PMD is unsynced.  |
| SGMII_LOCK | 4    | rh   | <b>SGMII PLL Lock</b><br>Indicates whether the PMA/PMD receive PLL has achieved lock. This is independent of availability of valid data at RXP/RXM input.<br>0 <sub>B</sub> <b>UNLOCKED</b> PMA/PMD receive PLL is unlocked.<br>1 <sub>B</sub> <b>LOCKED</b> PMA/PMD receive PLL is locked.   |
| SGMII_SYNC | 3    | rh   | <b>SGMII PMD/PMA Ready</b><br>Indicates whether the PMA/PMD is able to successfully synch and extract binary data from the incoming differential signals in the RXP/RXM input (when present). Note: This ready status can also be extracted by reading RX_VALID bit in the SGMII_PHY_STAT internal status register.<br>0 <sub>B</sub> <b>NOT_RDY</b> PMA/PMD core is not able to extract data.<br>1 <sub>B</sub> <b>RDY</b> PMA/PMD core is able to extract data. |
| SGMII_DIS  | 0    | rw   | <b>SGMII Macro Disable</b><br>This is a high-active level sensitive signal. When activated, inhibits the all activity of the macro and the PMA/PMD core in particular.<br><br><i>Note: The macro is not activated by its non-assertion, it still must be brought up in the proper sequence either by hardware signals or by programming.</i><br><br>0 <sub>B</sub> <b>EN</b> SGMII Macro is enabled.<br>1 <sub>B</sub> <b>DIS</b> SGMII Macro is disabled.        |

**NCO1 LSB Configuration Register**

It configures NCO1 bit 15 to 0 for generating strobe of 125 MHz average frequency with system clock.

| NCO1_LSB<br>NCO1 LSB Configuration Register | Offset<br>F958 <sub>H</sub> | Reset Value<br>D098 <sub>H</sub> |
|---|-----------------------------|----------------------------------|
| 15  |                             | 8                                |
| <b>NCO1_LSB</b>                             |                             |                                  |
| rw  |                             |                                  |
| 7   |                             | 0                                |
| <b>NCO1_LSB</b>                             |                             |                                  |
| rw  |                             |                                  |

| Field    | Bits | Type | Description   |
|----------|------|------|---|
| NCO1_LSB | 15:0 | rw   | <b>NCO1 LSB</b><br>NCO1 value must be 125 MHz/SYS_CLK_Freq* 2 <sup>24</sup> . |

**NCO1 MSB Configuration Register**

It configures NCO1 bit 23 to 16 for generating strobe of 125 MHz average frequency with system clock.

| NCO1_MSB<br>NCO1 MSB Configuration Register | Offset<br>F95C <sub>H</sub> | Reset Value<br>005E <sub>H</sub> |
|---|-----------------------------|----------------------------------|
| 15  |                             | 8                                |
| <b>Res</b>                                  |                             |                                  |
| 7   |                             | 0                                |
| <b>NCO1_MSB</b>                             |                             |                                  |
| rw  |                             |                                  |

| Field    | Bits | Type | Description   |
|----------|------|------|---|
| NCO1_MSB | 7:0  | rw   | <b>NCO1 MSB</b><br>NCO1 value must be 125 MHz/SYS_CLK_Freq* 2 <sup>24</sup> . |

**NCO2 LSB Configuration Register**

It configures NCO1 bit 15 to 0 for generating strobe of 312.5 MHz or 250 MHz average frequency with system clock.

| NCO2_LSB                        | Offset            | Reset Value       |
|---------------------------------|-------------------|-------------------|
| NCO2 LSB Configuration Register | F960 <sub>H</sub> | 097C <sub>H</sub> |
| 15                              |                   | 8                 |
| NCO2_LSB                        |                   |                   |
| rw                              |                   |                   |
| 7                               |                   | 0                 |
| NCO2_LSB                        |                   |                   |
| rw                              |                   |                   |

| Field    | Bits | Type | Description   |
|----------|------|------|---|
| NCO2_LSB | 15:0 | rw   | <b>NCO2 LSB</b><br>NCO2 value must be 312.5 MHz/SYS_CLK_Freq* 2 <sup>24</sup> or 250 MHz/SYS_CLK_Freq*2 <sup>24</sup> . |

**NCO2 MSB Configuration Register**

It configures NCO2 bit 23 to 16 for generating strobe of 312.5 MHz or 250 MHz average frequency with system clock.

| NCO2_MSB                        | Offset            | Reset Value       |
|---------------------------------|-------------------|-------------------|
| NCO2 MSB Configuration Register | F964 <sub>H</sub> | 00ED <sub>H</sub> |
| 15                              |                   | 8                 |
| Res                             |                   |                   |
| 7                               |                   | 0                 |
| NCO2_MSB                        |                   |                   |
| rw                              |                   |                   |

| Field    | Bits | Type | Description   |
|----------|------|------|---|
| NCO2_MSB | 7:0  | rw   | <b>NCO2 MSB</b><br>NCO2 value must be 312.5 MHz/SYS_CLK_Freq* 2 <sup>24</sup> or 250 MHz/SYS_CLK_Freq*2 <sup>24</sup> . |

**NCO Control**

This controls NCO1 and NCO2 operation

| NCO_CTRL    | Offset            | Reset Value       |
|-------------|-------------------|-------------------|
| NCO Control | F968 <sub>H</sub> | 0000 <sub>H</sub> |
| 15          |                   | 8                 |
| Res         |                   |                   |
| 7           | 4                 | 0                 |
|             | 3                 | 2                 |
|             | 1                 | 0                 |
|             | Res               | SGMII_HSP         |
|             |                   | SGMIISEL          |
|             |                   | FORCE0            |
|             |                   | rw                |
|             |                   | rw                |
|             |                   | rw                |

| Field     | Bits | Type | Description   |
|-----------|------|------|---|
| SGMII_HSP | 3:2  | rw   | <b>SGMII High Speed Selection</b><br>When data rate is 1Gbps, NCO1 must be selected for SGMII clock.<br>Otherwise, NCO2 is selected for SGMII clock.<br>00 <sub>B</sub> <b>1Gbps</b> 1Gbps data rate or below<br>10 <sub>B</sub> <b>2Gbps</b> 2Gbps data rate.<br>11 <sub>B</sub> <b>2_5Gbps</b> 2.5Gbps data rate. |
| SGMIISEL  | 1    | rw   | <b>SGMII Clock NCO Selection</b><br>0 <sub>B</sub> <b>NCO1</b> NCO1 output strobe is used for GMII* interface clock for the port connecting to SGMII.<br>1 <sub>B</sub> <b>NCO2</b> NCO2 output strobe is used for GMII* interface clock for the port connecting to SGMII.  |
| FORCE0    | 0    | rw   | <b>Reset NCO1 and NCO2 counter to 0</b><br>0 <sub>B</sub> <b>NIL</b> NCO1 and NCO2 counters run.<br>1 <sub>B</sub> <b>ZERO</b> NCO1 and NCO2 counter stay at 0.   |

### 4.1.9 Reset Control Unit Registers

This section describes all registers in RCU module.

#### Reset Status Register

After a reset, the read-only reset status register RST\_STAT indicates the type of reset that occurred and indicates which parts of the chip were affected by the reset.

| RESET_STATUS          |    | Offset            | Reset Value       |
|-----------------------|----|-------------------|-------------------|
| Reset Status Register |    | FA00 <sub>H</sub> | 8000 <sub>H</sub> |
| 15                    | 14 |                   | 8                 |
| <b>HRST</b>           |    | <b>RECORD</b>     |                   |
| rh                    |    | rw                |                   |
| 7                     |    |                   | 1 0               |
|                       |    | <b>RECORD</b>     | <b>INIT</b>       |
|                       |    | rw                | rw                |

| Field  | Bits | Type | Description  |
|--------|------|------|--|
| HRST   | 15   | rh   | <b>Hardware Reset Cause Flag</b><br>0 <sub>B</sub> <b>SRST</b> The last reset is software reset.<br>1 <sub>B</sub> <b>HRST</b> The last reset is hardware reset.                             |
| RECORD | 14:1 | rw   | <b>Last Reset Record</b><br>The value is not cleared by software reset.  |
| INIT   | 0    | rw   | <b>Initialization Done Flag</b><br>The value is not cleared by software reset.<br>0 <sub>B</sub> <b>NO</b> Initialization is not done.<br>1 <sub>B</sub> <b>DONE</b> Initialization is done. |

#### Reset Request Register

The Reset Request Register RST\_REQ is used to generate a software reset. Unlike the other reset types, the software reset can exclude functions from reset. A software reset is invoked by writing '1' to register RST\_REQ.

*Note: Bit 2 and 3 of this Reset Request Register (RST\_REQ) must always be written as '1'.*

| RST_REQ                | Offset            | Reset Value       |    |    |    |   |   |
|------------------------|-------------------|-------------------|----|----|----|---|---|
| Reset Request Register | FA01 <sub>H</sub> | 002F <sub>H</sub> |    |    |    |   |   |
| 15                     | 14                | 13                | 12 | 11 | 10 | 9 | 8 |

**Registers**

|             |             |            |              |            |             |            |            |
|-------------|-------------|------------|--------------|------------|-------------|------------|------------|
| <b>SRST</b> | <b>RD14</b> | <b>Res</b> | <b>G0RST</b> | <b>Res</b> | <b>RD10</b> | <b>RD9</b> | <b>Res</b> |
| rwh         | rw          |            | rwh          |            | rw          | rw         |            |
| 7           | 6           | 5          | 4            | 3          | 2           | 1          | 0          |
| <b>RD7</b>  | <b>RD6</b>  | <b>RD5</b> | <b>RD4</b>   | <b>RD3</b> | <b>RD2</b>  | <b>RD1</b> | <b>RD0</b> |
| rw          | rw          | rw         | rw           | rw         | rw          | rw         | rw         |

| Field | Bits | Type | Description   |
|-------|------|------|---|
| SRST  | 15   | rwh  | <b>Enable Global Software Reset</b><br>Configures the global software reset. Reset is automatically deactivated after some cycles.<br>0 <sub>B</sub> <b>Nil</b> Global software reset is not issued.<br>1 <sub>B</sub> <b>REQ</b> Global software reset is triggered.   |
| RD14  | 14   | rw   | <b>Reset Request for Reset Domain RD14</b><br>Configures the reset domain 14. Software to decide the required duration. Software reset MGE module.<br>MGE reset type 2 resets all logics excluding register file in MGE module.<br>0 <sub>B</sub> <b>Disabled</b> MGE software reset type 2 is disabled.<br>1 <sub>B</sub> <b>Enabled</b> MGE software reset type 2 is enabled. |
| G0RST | 12   | rwh  | <b>Enable GPHY0 Reset</b><br>Configures the GPHY0 reset. Reset is automatically deactivated after some cycles.<br>0 <sub>B</sub> <b>Nil</b> GPHY0 reset is not issued.<br>1 <sub>B</sub> <b>REQ</b> GPHY0 reset is triggered.   |
| RD10  | 10   | rw   | <b>Reset Request for Reset Domain RD10</b><br>Configures the reset domain 10. Software to decide the required duration. Software reset GPIO module.<br>0 <sub>B</sub> <b>Disabled</b> GPIO software reset is disabled.<br>1 <sub>B</sub> <b>Enabled</b> GPIO software reset is enabled.   |
| RD9   | 9    | rw   | <b>Reset Request for Reset Domain RD9</b><br>Configures the reset domain 9. Software to decide the required duration. Software reset MGE module.<br>0 <sub>B</sub> <b>Disabled</b> MGE software reset is disabled.<br>1 <sub>B</sub> <b>Enabled</b> MGE software reset is enabled.  |
| RD7   | 7    | rw   | <b>Reset Request for Reset Domain RD7</b><br>Configures the reset domain 0. Software to decide the required duration. Software reset CDB.<br>0 <sub>B</sub> <b>Disabled</b> CDB software reset is disabled.<br>1 <sub>B</sub> <b>Enabled</b> CDB software reset is enabled.   |
| RD6   | 6    | rw   | <b>Reset Request for Reset Domain RD6</b><br>Configures the reset domain 6. Software to decide the required duration. Software reset GPHY Shell.<br>0 <sub>B</sub> <b>Disabled</b> GPHY Shell software reset is disabled.<br>1 <sub>B</sub> <b>Enabled</b> GPHY Shell software reset is enabled.  |

**Registers**

| Field | Bits | Type | Description   |
|-------|------|------|---|
| RD5   | 5    | rw   | <b>Reset Request for Reset Domain RD5</b><br>Configures the reset domain 5. Software to decide the required duration. Software reset SGMII Shell.<br>0 <sub>B</sub> <b>Disabled</b> SGMII Shell reset is disabled.<br>1 <sub>B</sub> <b>Enabled</b> SGMII Shell reset is enabled.                   |
| RD4   | 4    | rw   | <b>Reset Request for Reset Domain RD4</b><br>Configures the reset domain 4. Software to decide the required duration.<br>0 <sub>B</sub> <b>Disabled</b> Boot loader reset is disabled.<br>1 <sub>B</sub> <b>Enabled</b> Boot loader reset is enabled.   |
| RD3   | 3    | rw   | <b>Reserved</b><br>Must always be written as '1'.   |
| RD2   | 2    | rw   | <b>Reserved</b><br>Must always be written as '1'.   |
| RD1   | 1    | rw   | <b>Reset Request for Reset Domain RD1</b><br>Configures the reset domain 1. Software to decide the required duration. Software reset GPHY1 Macro.<br>0 <sub>B</sub> <b>Disabled</b> GPHY1 Macro software reset is disabled.<br>1 <sub>B</sub> <b>Enabled</b> GPHY1 Macro software reset is enabled. |
| RD0   | 0    | rw   | <b>Reset Request for Reset Domain RD0</b><br>Configures the reset domain 0. Software to decide the required duration. Software reset GPHY0 Macro.<br>0 <sub>B</sub> <b>Disabled</b> GPHY0 Macro software reset is disabled.<br>1 <sub>B</sub> <b>Enabled</b> GPHY0 Macro software reset is enabled. |

**MANU ID Register**

This shows Manufacturer ID and part number.

| MANU_ID          | Offset            | Reset Value       |
|------------------|-------------------|-------------------|
| MANU ID Register | FA10 <sub>H</sub> | 3713 <sub>H</sub> |
| 15               | 12                | 11                |
| PNUML            |                   | MANID             |
| rh               |                   | rh                |
| 7                |                   | 1                 |
| MANID            |                   | FIX1              |
| rh               |                   | rh                |

| Field | Bits  | Type | Description  |
|-------|-------|------|--|
| PNUML | 15:12 | rh   | <b>Part Number LSB</b><br>Part Number LSB                              |
| MANID | 11:1  | rh   | <b>Manufacturer ID</b><br>Manufacturer ID, it must be 389 <sub>H</sub> |

**Registers**

| Field | Bits | Type | Description                      |
|-------|------|------|----------------------------------|
| FIX1  | 0    | rh   | <b>Fixed to 1</b><br>Fixed to 1. |

**Part Number Register**

This shows part number and chip version.

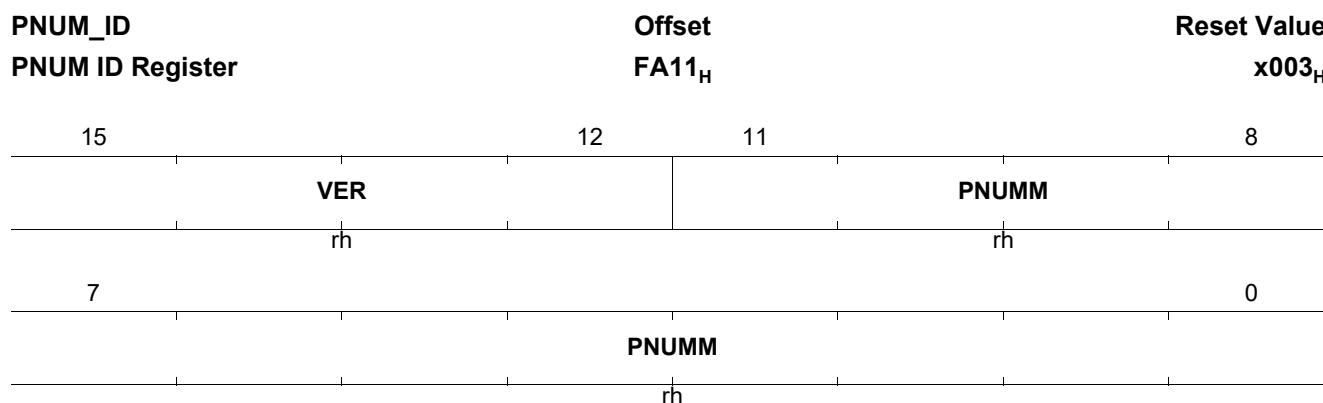

| Field | Bits  | Type | Description  |
|-------|-------|------|--|
| VER   | 15:12 | rh   | <b>Chip Version</b><br>Chip Version ID<br>0010 <sub>B</sub> <b>V1.2</b> Chip version ID register value is '2' for V1.2.<br>0011 <sub>B</sub> <b>V1.3</b> Chip version ID register value is '3' for V1.3. |
| PNUMM | 11:0  | rh   | <b>Part Number MSB</b><br>Part Number, Fixed to 003 <sub>H</sub>   |



**GPIO PAD Driver Strength Control 0 Register**

This configures PAD driver strength control.

|  |                         |                         |
|--|-------------------------|-------------------------|
| <b>GPIO_DRIVE0_CFG</b>                             | <b>Offset</b>           | <b>Reset Value</b>      |
| <b>GPIO PAD Driver Strength 0 Control Register</b> | <b>FA70<sub>H</sub></b> | <b>3FFF<sub>H</sub></b> |

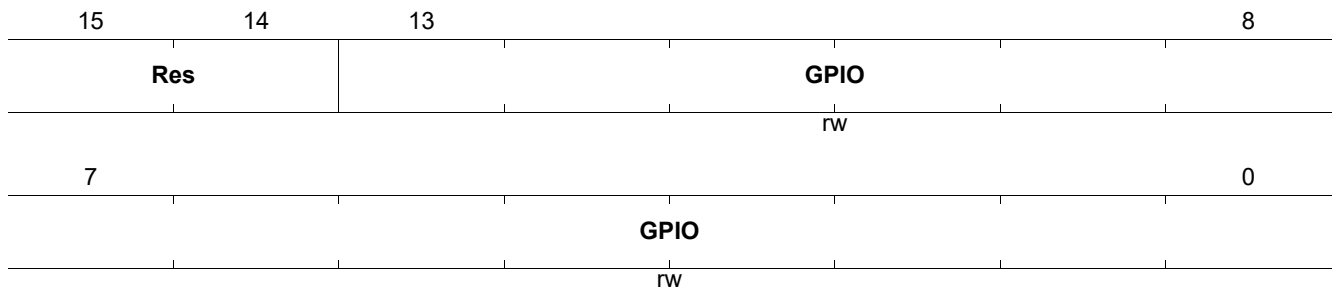

| Field | Bits | Type | Description  |
|-------|------|------|--|
| GPIO  | 13:0 | rw   | <b>GPIO PAD Drive Strength Bit 0</b><br>PAD driver strength.<br>00 <sub>B</sub> <b>2mA</b> PAD drive strength is 2 mA.<br>01 <sub>B</sub> <b>4mA</b> PAD drive strength is 4 mA.<br>10 <sub>B</sub> <b>8mA</b> PAD drive strength is 8 mA.<br>11 <sub>B</sub> <b>12mA</b> PAD drive strength is 12 mA. |

**GPIO PAD Driver Strength Control 1 Register**

This configures PAD driver strength control.

|  |                         |                         |
|--|-------------------------|-------------------------|
| <b>GPIO_DRIVE1_CFG</b>                             | <b>Offset</b>           | <b>Reset Value</b>      |
| <b>GPIO PAD Driver Strength 1 Control Register</b> | <b>FA71<sub>H</sub></b> | <b>0000<sub>H</sub></b> |

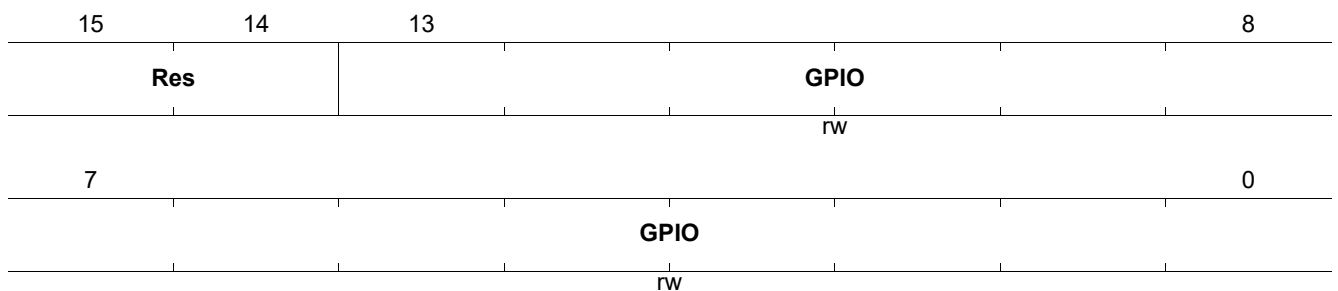

| Field | Bits | Type | Description  |
|-------|------|------|--|
| GPIO  | 13:0 | rw   | <b>GPIO PAD Drive Strength Bit 1</b><br>PAD driver strength.<br>00 <sub>B</sub> <b>2mA</b> PAD drive strength is 2 mA.<br>01 <sub>B</sub> <b>4mA</b> PAD drive strength is 4 mA.<br>10 <sub>B</sub> <b>8mA</b> PAD drive strength is 8 mA.<br>11 <sub>B</sub> <b>12mA</b> PAD drive strength is 12 mA. |

**GPIO PAD Slew Control Register**

This configures GPIO PAD Slew control.

| GPIO_SLEW_CFG                  |            | Offset            |             | Reset Value       |   |
|--------------------------------|------------|-------------------|-------------|-------------------|---|
| GPIO PAD Slew Control Register |            | FA72 <sub>H</sub> |             | 0000 <sub>H</sub> |   |
| 15                             | 14         | 13                |             |                   | 8 |
| <b>PAD_VOL</b>                 | <b>Res</b> |                   |             | <b>GPIO</b>       |   |
| rw                             |            |                   |             | rw                |   |
| 7                              |            |                   |             |                   | 0 |
|                                |            |                   | <b>GPIO</b> |                   |   |
|                                |            |                   | rw          |                   |   |

| Field   | Bits | Type | Description   |
|---------|------|------|---|
| PAD_VOL | 15   | rw   | <b>GPIO1 PAD Voltage Supply Level</b><br>PAD Slew rate.<br>0 <sub>B</sub> <b>HIGH</b> GPIO group 1 and Reset PAD Voltage supply level is 3.3 V or 2.5 V.<br>1 <sub>B</sub> <b>LOW</b> GPIO group 1 and Reset PAD Voltage supply level is 1.8 V. |
| GPIO    | 13:0 | rw   | <b>GPIO PAD Slew Control</b><br>PAD slew control.<br>0 <sub>B</sub> <b>Slow</b> Slow slew.<br>1 <sub>B</sub> <b>Fast</b> Fast slew.   |

**GPIO2 PAD Driver Strength Control 0 Register**

This configures PAD driver strength control.

| GPIO2_DRIVE0_CFG                             |    | Offset            |              | Reset Value       |   |
|--|----|-------------------|--------------|-------------------|---|
| GPIO2 PAD Driver Strength 0 Control Register |    | FA74 <sub>H</sub> |              | 7FFF <sub>H</sub> |   |
| 15   | 14 |                   |              |                   | 8 |
| <b>Res</b>                                   |    |                   |              | <b>GPIO2</b>      |   |
|  |    |                   |              | rw                |   |
| 7  |    |                   |              |                   | 0 |
|  |    |                   | <b>GPIO2</b> |                   |   |
|  |    |                   | rw           |                   |   |

| Field | Bits | Type | Description   |
|-------|------|------|---|
| GPIO2 | 14:0 | rw   | <b>GPIO2 PAD Drive Strength Bit 0</b><br>PAD driver strength.<br>00 <sub>B</sub> <b>2mA</b> PAD drive strength is 2 mA.<br>01 <sub>B</sub> <b>4mA</b> PAD drive strength is 4 mA.<br>10 <sub>B</sub> <b>8mA</b> PAD drive strength is 8 mA.<br>11 <sub>B</sub> <b>12mA</b> PAD drive strength is 12 mA. |

**GPIO2 PAD Driver Strength Control 1 Register**

This configures PAD driver strength control.

| GPIO2_DRIVE1_CFG                             | Offset            | Reset Value       |
|--|-------------------|-------------------|
| GPIO2 PAD Driver Strength 1 Control Register | FA75 <sub>H</sub> | 0000 <sub>H</sub> |
| 15   | 14                | 8                 |
| Res  | GPIO2             |                   |
|  | rw                |                   |
| 7  |                   | 0                 |
|  | GPIO2             |                   |
|  | rw                |                   |

| Field | Bits | Type | Description   |
|-------|------|------|---|
| GPIO2 | 14:0 | rw   | <b>GPIO2 PAD Drive Strength Bit 1</b><br>PAD driver strength.<br>00 <sub>B</sub> <b>2mA</b> PAD drive strength is 2 mA.<br>01 <sub>B</sub> <b>4mA</b> PAD drive strength is 4 mA.<br>10 <sub>B</sub> <b>8mA</b> PAD drive strength is 8 mA.<br>11 <sub>B</sub> <b>12mA</b> PAD drive strength is 12 mA. |

**GPIO2 PAD Slew Control Register**

This configures GPIO2 PAD Slew control.

| GPIO2_SLEW_CFG              |    | Offset            | Reset Value       |
|-----------------------------|----|-------------------|-------------------|
| GPIO2 Slew Control Register |    | FA76 <sub>H</sub> | 0000 <sub>H</sub> |
| 15                          | 14 |                   | 8                 |
| <b>PAD_VOL</b>              |    | <b>GPIO2</b>      |                   |
| rw                          |    | rw                |                   |
| 7                           |    |                   | 0                 |
|                             |    | <b>GPIO2</b>      |                   |
|                             |    | rw                |                   |

| Field   | Bits | Type | Description   |
|---------|------|------|---|
| PAD_VOL | 15   | rw   | <b>GPIO2 PAD Voltage Supply Level</b><br>PAD Slew rate.<br>0 <sub>B</sub> <b>HIGH</b> GPIO group 2 PAD Voltage supply level is 3.3 V or 2.5 V.<br>1 <sub>B</sub> <b>LOW</b> GPIO group 2 PAD Voltage supply level is 1.8 V. |
| GPIO2   | 14:0 | rw   | <b>GPIO PAD Slew Control</b><br>PAD slew control.<br>0 <sub>B</sub> <b>Slow</b> Slow Slew.<br>1 <sub>B</sub> <b>Fast</b> Fast Slew.   |

**RGMII PAD Slew Control Register**

This configures PAD driver strength control.

| RGMII_SLEW_CFG                  |            | Offset            | Reset Value       |                  |                  |                |                |
|---------------------------------|------------|-------------------|-------------------|------------------|------------------|----------------|----------------|
| RGMII PAD Slew Control Register |            | FA78 <sub>H</sub> | 0000 <sub>H</sub> |                  |                  |                |                |
| 15                              | 12         | 11                | 10                | 9                | 8                |                |                |
|                                 | <b>Res</b> | <b>PAD_TX_PU</b>  | <b>PAD_TX_PD</b>  | <b>PAD_RX_PU</b> | <b>PAD_RX_PD</b> |                |                |
|                                 |            | rw                | rw                | rw               | rw               |                |                |
| 7                               | 6          | 5                 | 4                 | 3                | 2                | 1              | 0              |
|                                 | <b>Res</b> | <b>PAD_VOL_TX</b> | <b>PAD_VOL_RX</b> | <b>DRV_TXD</b>   | <b>DRV_TXC</b>   | <b>DRV_RXD</b> | <b>DRV_RXC</b> |
|                                 |            | rw                | rw                | rw               | rw               | rw             | rw             |

| Field     | Bits | Type | Description   |
|-----------|------|------|---|
| PAD_TX_PU | 11   | rw   | <b>RGMII TX PAD Pull Up</b><br>Control TX PAD (Including Clock, Data and Control) Pull Up<br>0 <sub>B</sub> <b>DIS</b> RGMII TX PAD pull up is disabled.<br>1 <sub>B</sub> <b>EN</b> RGMII TX PAD pull up is enabled. |

| Field      | Bits | Type | Description   |
|------------|------|------|---|
| PAD_TX_PD  | 10   | rw   | <b>RGMII TX PAD Pull Down</b><br>Control TX PAD (Including Clock, Data and Control) Pull Down<br>0 <sub>B</sub> <b>DIS</b> RGMII TX PAD pull down is disabled.<br>1 <sub>B</sub> <b>EN</b> RGMII TX PAD pull down is enabled. |
| PAD_RX_PU  | 9    | rw   | <b>RGMII RX PAD Pull Up</b><br>Control RX PAD (Including Clock, Data and Control) Pull Up<br>0 <sub>B</sub> <b>DIS</b> RGMII RX PAD pull up is disabled.<br>1 <sub>B</sub> <b>EN</b> RGMII RX PAD pull up is enabled.         |
| PAD_RX_PD  | 8    | rw   | <b>RGMII RX PAD Pull Down</b><br>Control RX PAD (Including Clock, Data and Control) Pull Down<br>0 <sub>B</sub> <b>DIS</b> RGMII RX PAD pull down is disabled.<br>1 <sub>B</sub> <b>EN</b> RGMII RX PAD pull down is enabled. |
| PAD_VOL_TX | 5    | rw   | <b>RGMII TX PAD Voltage Supply Level</b><br>TX PAD Voltage Supply<br>0 <sub>B</sub> <b>3.3V</b> RGMII PAD Voltage supply level is 3.3 V.<br>1 <sub>B</sub> <b>2.5V</b> RGMII PAD Voltage supply level is 2.5 V.               |
| PAD_VOL_RX | 4    | rw   | <b>RGMII RX PAD Voltage Supply Level</b><br>RX PAD Voltage Supply<br>0 <sub>B</sub> <b>3.3V</b> RGMII PAD Voltage supply level is 3.3 V.<br>1 <sub>B</sub> <b>2.5V</b> RGMII PAD Voltage supply level is 2.5 V.               |
| DRV_TXD    | 3    | rw   | <b>RGMII TX Non-Clock PAD Slew Rate</b><br>PAD Slew rate.<br>0 <sub>B</sub> <b>Normal</b> Normal Slew Rate.<br>1 <sub>B</sub> <b>Slow</b> Slow Slew Rate.   |
| DRV_TXC    | 2    | rw   | <b>RGMII TX Clock Slew Rate</b><br>PAD Slew rate.<br>0 <sub>B</sub> <b>Normal</b> Normal Slew Rate.<br>1 <sub>B</sub> <b>Slow</b> Slow Slew Rate.   |
| DRV_RXD    | 1    | rw   | <b>RGMII RX Non-Clock PAD Slew Rate</b><br>PAD Slew rate.<br>0 <sub>B</sub> <b>Normal</b> Normal Slew Rate.<br>1 <sub>B</sub> <b>Slow</b> Slow Slew Rate.   |
| DRV_RXC    | 0    | rw   | <b>RGMII RX Clock Slew Rate</b><br>PAD driver strength.<br>0 <sub>B</sub> <b>Normal</b> Normal Slew Rate.<br>1 <sub>B</sub> <b>Slow</b> Slow Slew Rate.   |

**Pin-Strapping Register 0**

The configuration input pin(s) are sampled and latched at the rising edge of Hardware Reset input. This register cannot be reset by global software reset and module software reset.

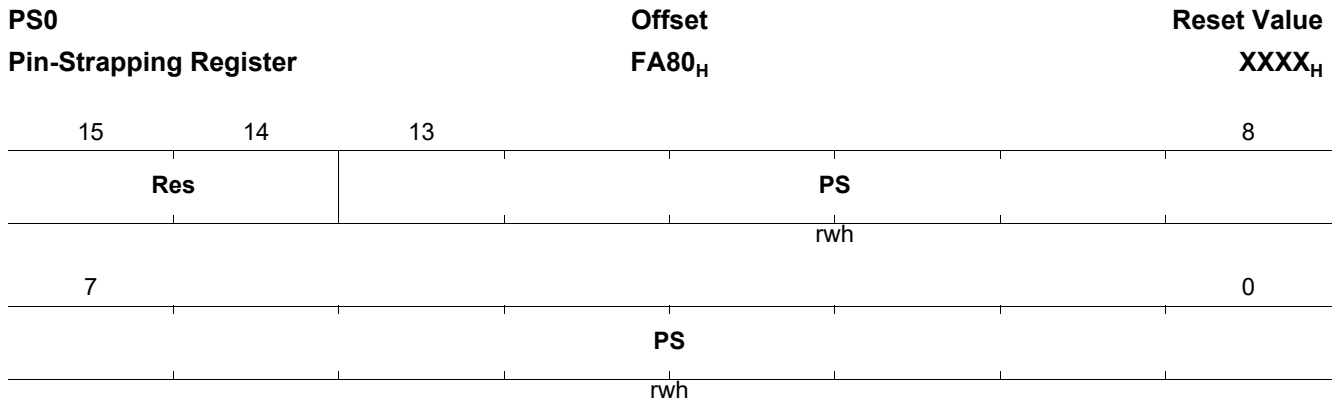

| Field | Bits | Type | Description                      |
|-------|------|------|----------------------------------|
| PS    | 13:0 | rwh  | Pin-Strapping of GPIO0 to GPIO13 |

**Pin-Strapping Register 1**

The configuration input pin(s) are sampled and latched at the rising edge of Hardware Reset input. This register cannot be reset by global software reset and module software reset.

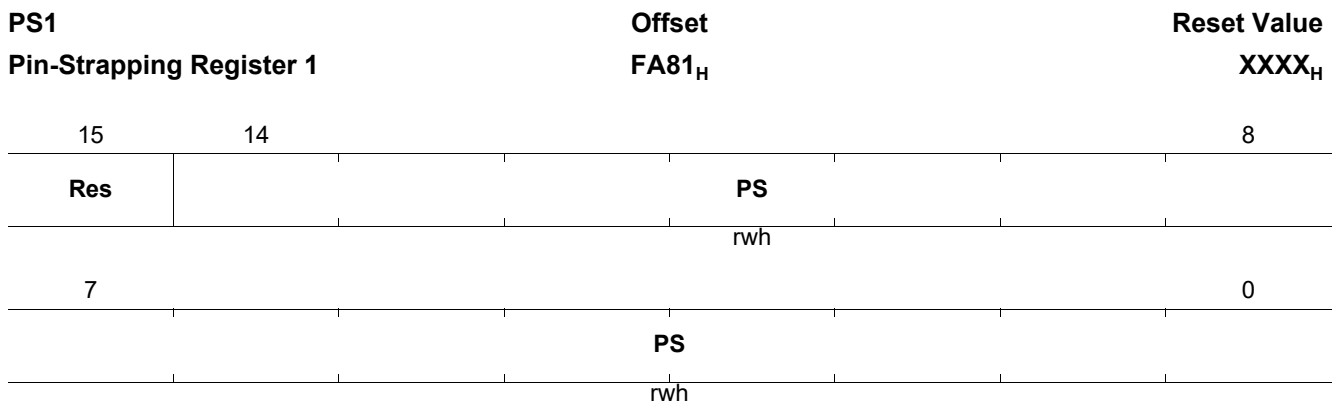

| Field | Bits | Type | Description                       |
|-------|------|------|-----------------------------------|
| PS    | 14:0 | rwh  | Pin-Strapping of GPIO16 to GPIO30 |

### 4.1.10 GPIO Registers

The individual control and data bits of each digital parallel port are implemented in a number of registers. Bits with the same meaning and function are assembled together in the same register. Each parallel port consists of a set of registers. The registers are used to configure and use the port as general purpose I/O or alternate function input/output.

#### GPIO Data Output Register

When a pin is used as general purpose output (GPIO), output data is written into register GPIO\_OUT.

| GPIO_OUT                  | Offset            | Reset Value       |
|---------------------------|-------------------|-------------------|
| GPIO Data Output Register | F380 <sub>H</sub> | 0000 <sub>H</sub> |
| 15 14 13                  |                   | 0                 |
| Res                       | GPIO              |                   |
|                           | rw                |                   |

| Field | Bits | Type | Description   |
|-------|------|------|---|
| GPIO  | 13:0 | rw   | <b>GPIO Output Value</b><br>0 <sub>B</sub> <b>LOW</b> Output value = 0<br><i>Note: Default value after reset</i><br>1 <sub>B</sub> <b>HIGH</b> Output value = 1 |

#### GPIO Data Input Register

The value at a pin can be read through the read-only register GPIO\_IN. The data input register GPIO\_IN always contains a latched value of the assigned pin.

| GPIO_IN                  | Offset            | Reset Value       |
|--------------------------|-------------------|-------------------|
| GPIO Data Input Register | F381 <sub>H</sub> | 0000 <sub>H</sub> |
| 15 14 13                 |                   | 0                 |
| Res                      | GPIO              |                   |
|                          | rh                |                   |

| Field | Bits | Type | Description   |
|-------|------|------|---|
| GPIO  | 13:0 | rh   | <b>GPIO Input Value</b><br>0 <sub>B</sub> <b>LOW</b> Input value = 0<br>1 <sub>B</sub> <b>HIGH</b> Output value = 1 |

**GPIO Direction Register**

The direction of port pins can be controlled in the following ways:

- Controlled by Px\_DIR register when used for GPIO and controlled by the peripheral when used for alternate function.
- Controlled by Px\_DIR register when used as GPIO and fixed direction when used for alternate function.

When the port direction is controlled by the respective direction register Px\_DIR, the following encoding is defined.

| GPIO_DIR                | Offset            | Reset Value       |
|-------------------------|-------------------|-------------------|
| GPIO Direction Register | F382 <sub>H</sub> | 0000 <sub>H</sub> |
| 15 14 13                |                   | 0                 |
| Res                     | GPIO              |                   |
|                         | rw                |                   |

| Field | Bits | Type | Description   |
|-------|------|------|---|
| GPIO  | 13:0 | rw   | <b>GPIO Direction Control</b><br>0 <sub>B</sub> <b>Input</b> GPIO is in input mode<br><i>Note: Default value after reset</i><br>1 <sub>B</sub> <b>Output</b> GPIO is in output mode |

**GPIO Alternate Function Select Register 0**

Alternate functions are selected via an output multiplexer which can select up to four output lines. This multiplexer can be controlled by the signals of Register [GPIO\\_ALTSELO](#) and 1.

Selection of alternate functions are defined in registers [GPIO\\_ALTSELO](#) and 1.

| GPIO_ALTSELO                                | Offset            | Reset Value       |
|---|-------------------|-------------------|
| Port 0 Alternate Function Select Register 0 | F383 <sub>H</sub> | 0000 <sub>H</sub> |
| 15 14 13                                    |                   | 0                 |
| Res   | GPIO              |                   |
|   | rw                |                   |

| Field | Bits | Type | Description   |
|-------|------|------|---|
| GPIO  | 13:0 | rw   | <b>GPIO Alternate Function Selection LSB</b><br>GPIO Alternate Function Selection LSB |



**GPIO Alternate Function Select Register 1**

Alternate functions are selected via an output multiplexer which can select up to four output lines. This multiplexer can be controlled by the signals of Register **GPIO\_ALTSELO** and 1.

Selection of alternate functions are defined in registers **GPIO\_ALTSELO** and 1.

|  |                         |                         |
|--|-------------------------|-------------------------|
| <b>GPIO_ALTSEL1</b>                                | <b>Offset</b>           | <b>Reset Value</b>      |
| <b>Port 0 Alternate Function Select Register 1</b> | <b>F384<sub>H</sub></b> | <b>003C<sub>H</sub></b> |



| Field | Bits | Type | Description   |
|-------|------|------|---|
| GPIO  | 13:0 | rw   | <b>GPIO Alternate Function Selection MSB</b><br>GPIO Alternate Function Selection MSB |

**GPIO Open Drain Control Register**

Each pin in output mode can be switched to Open Drain Mode. When driven with 1, no driver is activated; when driven with 0, the pull-down transistor is activated.

|   |                         |                         |
|---|-------------------------|-------------------------|
| <b>GPIO_OD</b>                          | <b>Offset</b>           | <b>Reset Value</b>      |
| <b>GPIO Open Drain Control Register</b> | <b>F385<sub>H</sub></b> | <b>3FFF<sub>H</sub></b> |

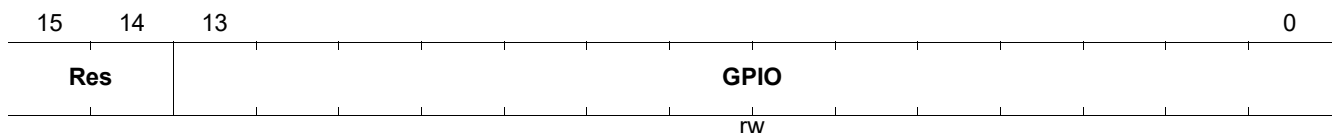

| Field | Bits | Type | Description  |
|-------|------|------|--|
| GPIO  | 13:0 | rw   | <b>GPIO Open Drain Mode</b><br>0 <sub>B</sub> <b>OD</b> Open Drain Mode, output is actively driven only for 0 state.<br>1 <sub>B</sub> <b>PP</b> Normal Mode, output is actively driven for 0 and 1 state. |

**Port 0 Pull-Up/Pull-Down Select Register**

Internal pull-up/pull-down devices can be optionally applied to pin. This offers the possibility to configure the following input characteristics:

- Tristate
- High-impedance with a weak pull-up device
- High-impedance with a weak pull-down device

And the following output characteristics:

- Push/pull (optional pull-up/pull-down)
- Open drain with internal pull-up
- Open drain with external pull-up

The pull-up/pull-down device can be fixed or controlled via the registers **GPIO\_PUDEN**. Register **GPIO\_PUDSEL** selects the type of pull-up/pull-down device, while register **GPIO\_PUDEN** enables or disables it. The pull-up/pull-down device can be selected pin-wise. The pull-up/pull-down devices are predefined for some pins after reset.

*Note: The selected pull-up/pull-down device is enabled by setting the respective bit in the Px\_PUDEN register.*

| <b>GPIO_PUDSEL</b>                            |    | <b>Offset</b>           | <b>Reset Value</b>      |
|---|----|-------------------------|-------------------------|
| <b>GPIO Pull-Up/Pull-Down Select Register</b> |    | <b>F386<sub>H</sub></b> | <b>3FFF<sub>H</sub></b> |
| 15  | 14 | 13                      | 0                       |
| <b>Res</b>                                    |    | <b>GPIO</b>             |                         |
|   |    | rw                      |                         |

| Field | Bits | Type | Description   |
|-------|------|------|---|
| GPIO  | 13:0 | rw   | <b>GPIO Pull Up/Down Mode</b><br>0 <sub>B</sub> <b>PD</b> Internal weak pull down is enabled.<br>1 <sub>B</sub> <b>PU</b> Internal weak pull up is enabled. |

#### GPIO Pull-Up/Pull-Down Enable Register

See the previous register description.

| <b>GPIO_PUDEN</b>                             |    | <b>Offset</b>           | <b>Reset Value</b>      |
|---|----|-------------------------|-------------------------|
| <b>GPIO Pull-Up/Pull-Down Enable Register</b> |    | <b>F387<sub>H</sub></b> | <b>3FFF<sub>H</sub></b> |
| 15  | 14 | 13                      | 0                       |
| <b>Res</b>                                    |    | <b>GPIO</b>             |                         |
|   |    | rw                      |                         |

| Field | Bits | Type | Description   |
|-------|------|------|---|
| GPIO  | 13:0 | rw   | <b>GPIO Pull Up/Down Enable</b><br>0 <sub>B</sub> <b>Disable</b> Internal weak pull up/down is disabled.<br>1 <sub>B</sub> <b>Enable</b> Internal weak pull up/down is enabled. |

**GPIO2 Data Output Register**

When a pin is used as general purpose output (GPIO), output data is written into register GPIO\_OUT.

|                                   |                         |                         |
|-----------------------------------|-------------------------|-------------------------|
| <b>GPIO2_OUT</b>                  | <b>Offset</b>           | <b>Reset Value</b>      |
| <b>GPIO2 Data Output Register</b> | <b>F390<sub>H</sub></b> | <b>0000<sub>H</sub></b> |

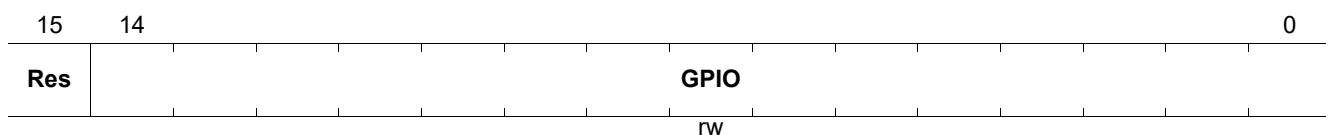

| Field | Bits | Type | Description   |
|-------|------|------|---|
| GPIO  | 14:0 | rw   | <b>GPIO Output Value</b><br>0 <sub>B</sub> <b>LOW</b> Output value = 0<br><i>Note: Default value after reset</i><br>1 <sub>B</sub> <b>HIGH</b> Output value = 1 |

**GPIO2 Data Input Register**

The value at a pin can be read through the read-only register GPIO\_IN. The data input register GPIO\_IN always contains a latched value of the assigned pin.

|                                  |                         |                         |
|----------------------------------|-------------------------|-------------------------|
| <b>GPIO2_IN</b>                  | <b>Offset</b>           | <b>Reset Value</b>      |
| <b>GPIO2 Data Input Register</b> | <b>F391<sub>H</sub></b> | <b>0000<sub>H</sub></b> |

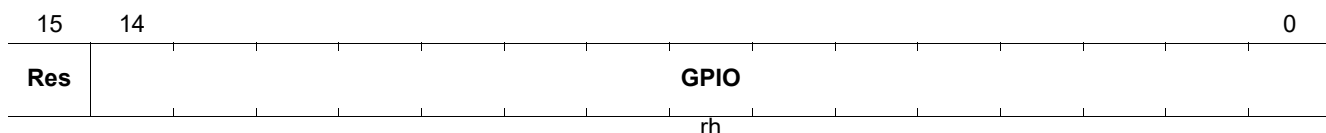

| Field | Bits | Type | Description   |
|-------|------|------|---|
| GPIO  | 14:0 | rh   | <b>GPIO Input Value</b><br>0 <sub>B</sub> <b>LOW</b> Input value = 0<br>1 <sub>B</sub> <b>HIGH</b> Output value = 1 |

**GPIO2 Direction Register**

The direction of port pins can be controlled in the following ways:

- Controlled by Px\_DIR register when used for GPIO and controlled by the peripheral when used for alternate function
- Controlled by Px\_DIR register when used as GPIO and fixed direction when used for alternate function

When the port direction is controlled by the respective direction register Px\_DIR, the following encoding is defined.

| GPIO2_DIR                | Offset            | Reset Value       |
|--------------------------|-------------------|-------------------|
| GPIO2 Direction Register | F392 <sub>H</sub> | 0000 <sub>H</sub> |

| 15  | 14   | 0 |
|-----|------|---|
| Res | GPIO |   |
| rw  |      |   |

| Field | Bits | Type | Description   |
|-------|------|------|---|
| GPIO  | 14:0 | rw   | <b>GPIO Direction Control</b><br>0 <sub>B</sub> <b>Input</b> GPIO is in input mode<br><i>Note: Default value after reset</i><br>1 <sub>B</sub> <b>Output</b> GPIO is in output mode |

**GPIO2 Alternate Function Select Register 0**

Alternate functions are selected via an output multiplexer which can select up to four output lines. This multiplexer can be controlled by the signals of Register [GPIO2\\_ALTSEL0](#) and 1.

Selection of alternate functions are defined in registers [GPIO2\\_ALTSEL0](#) and 1.

| GPIO2_ALTSEL0                               | Offset            | Reset Value       |
|---|-------------------|-------------------|
| Port 2 Alternate Function Select Register 0 | F393 <sub>H</sub> | 0000 <sub>H</sub> |

| 15  | 14   | 0 |
|-----|------|---|
| Res | GPIO |   |
| rw  |      |   |

| Field | Bits | Type | Description   |
|-------|------|------|---|
| GPIO  | 14:0 | rw   | <b>GPIO Alternate Function Selection LSB</b><br>GPIO Alternate Function Selection LSB |

**GPIO2 Alternate Function Select Register 1**

Alternate functions are selected via an output multiplexer which can select up to four output lines. This multiplexer can be controlled by the signals of Register **GPIO2\_ALTSELO** and 1.

Selection of alternate functions are defined in registers **GPIO2\_ALTSELO** and 1.

| GPIO2_ALTSEL1                                      |             | Offset                  | Reset Value             |
|--|-------------|-------------------------|-------------------------|
| <b>Port 2 Alternate Function Select Register 1</b> |             | <b>F394<sub>H</sub></b> | <b>0000<sub>H</sub></b> |
| 15   | 14          |                         | 0                       |
| <b>Res</b>   | <b>GPIO</b> |                         |                         |
|  | rw          |                         |                         |

| Field | Bits | Type | Description   |
|-------|------|------|---|
| GPIO  | 14:0 | rw   | <b>GPIO Alternate Function Selection MSB</b><br>GPIO Alternate Function Selection MSB |

**GPIO2 Open Drain Control Register**

Each pin in output mode can be switched to Open Drain Mode. When driven with 1, no driver is activated; when driven with 0, the pull-down transistor is activated.

| GPIO2_OD                                 |             | Offset                  | Reset Value             |
|--|-------------|-------------------------|-------------------------|
| <b>GPIO2 Open Drain Control Register</b> |             | <b>F395<sub>H</sub></b> | <b>7FFF<sub>H</sub></b> |
| 15                                       | 14          |                         | 0                       |
| <b>Res</b>                               | <b>GPIO</b> |                         |                         |
|  | rw          |                         |                         |

| Field | Bits | Type | Description  |
|-------|------|------|--|
| GPIO  | 14:0 | rw   | <b>GPIO Open Drain Mode</b><br>0 <sub>B</sub> <b>OD</b> Open Drain Mode, output is actively driven only for 0 state.<br>1 <sub>B</sub> <b>PP</b> Normal Mode, output is actively driven for 0 and 1 state. |

**Port 2 Pull-Up/Pull-Down Select Register**

Internal pull-up/pull-down devices can be optionally applied to pin. This offers the possibility to configure the following input characteristics:

- Tristate
- High-impedance with a weak pull-up device
- High-impedance with a weak pull-down device

And the following output characteristics:

- Push/pull (optional pull-up/pull-down)
- Open drain with internal pull-up
- Open drain with external pull-up



### 4.1.11 ICU Registers

#### IM0 Interrupt Status Register

Writing a 1 to a bit in the interrupt status register causes this bit to be cleared. Writing 0 to a bit does not change the value of the interrupt request flag. A read action to this register delivers the unmasked captured status of the interrupt request lines.

| IM0_ISR                              | Offset                  | Reset Value             |
|--------------------------------------|-------------------------|-------------------------|
| <b>IM0 Interrupt Status Register</b> | <b>F3C0<sub>H</sub></b> | <b>0000<sub>H</sub></b> |
| 15                                   | 12                      | 11                      |
| Res                                  |                         | IR11                    |
|                                      |                         | IR10                    |
|                                      |                         | Res                     |
|                                      |                         | IR7                     |
|                                      |                         | IR6                     |
|                                      |                         | IR5                     |
|                                      |                         | Res                     |
| 7                                    | 6                       | 5                       |
| IR7                                  |                         | IR6                     |
|                                      |                         | IR5                     |
|                                      |                         | Res                     |
| 15                                   | 12                      | 11                      |
|                                      |                         | IR11                    |
|                                      |                         | IR10                    |
|                                      |                         | Res                     |
| 7                                    | 6                       | 5                       |
| IR7                                  |                         | IR6                     |
|                                      |                         | IR5                     |
|                                      |                         | Res                     |

| Field | Bits | Type | Description   |
|-------|------|------|---|
| IR11  | 11   | lhsc | <b>Status of Interrupt Request SGMII</b><br>0 <sub>B</sub> <b>Inactive</b> There is no pending interrupt.<br>1 <sub>B</sub> <b>Active</b> There is pending interrupt request.             |
| IR10  | 10   | lhsc | <b>Status of Interrupt Request Packet Extraction</b><br>0 <sub>B</sub> <b>Inactive</b> There is no pending interrupt.<br>1 <sub>B</sub> <b>Active</b> There is pending interrupt request. |
| IR7   | 7    | lhsc | <b>Status of Interrupt Request MGE</b><br>0 <sub>B</sub> <b>Inactive</b> There is no pending interrupt.<br>1 <sub>B</sub> <b>Active</b> There is pending interrupt request.               |
| IR6   | 6    | lhsc | <b>Status of Interrupt Request xMII</b><br>0 <sub>B</sub> <b>Inactive</b> There is no pending interrupt.<br>1 <sub>B</sub> <b>Active</b> There is pending interrupt request.              |
| IR5   | 5    | lhsc | <b>Status of Interrupt Request GSWIP</b><br>0 <sub>B</sub> <b>Inactive</b> There is no pending interrupt.<br>1 <sub>B</sub> <b>Active</b> There is pending interrupt request.             |

#### IM0 EINT0 Interrupt Enable Register

Writing 1 to a bit enables the interrupt request line, while writing 0 to a bit disables the associated interrupt request line.

| IM0_EINT0_IER                              | Offset                  | Reset Value             |
|--|-------------------------|-------------------------|
| <b>IM0 EINT0 Interrupt Enable Register</b> | <b>F3C2<sub>H</sub></b> | <b>0000<sub>H</sub></b> |

**Registers**

|            |  |            |    |            |   |    |   |             |   |             |   |            |   |    |   |  |
|------------|--|------------|----|------------|---|----|---|-------------|---|-------------|---|------------|---|----|---|--|
| 15         |  |            | 12 |            |   | 11 |   | 10          |   | 9           |   | 8          |   |    |   |  |
| <b>Res</b> |  |            |    |            |   |    |   | <b>IR11</b> |   | <b>IR10</b> |   | <b>Res</b> |   |    |   |  |
|            |  |            |    |            |   |    |   | rw          |   | rw          |   |            |   |    |   |  |
| 7          |  |            | 6  |            | 5 |    | 4 |             | 3 |             | 2 |            | 1 |    | 0 |  |
| <b>IR7</b> |  | <b>IR6</b> |    | <b>IR5</b> |   |    |   |             |   | <b>Res</b>  |   |            |   |    |   |  |
| rw         |  | rw         |    | rw         |   | rw |   | rw          |   | rw          |   | rw         |   | rw |   |  |

| Field | Bits | Type | Description   |
|-------|------|------|---|
| IR11  | 11   | rw   | <b>Interrupt Enable SGMII</b><br>0 <sub>B</sub> <b>Disable</b> Interrupt request is disabled.<br>1 <sub>B</sub> <b>Active</b> Interrupt request is enabled.             |
| IR10  | 10   | rw   | <b>Interrupt Enable Packet Extraction</b><br>0 <sub>B</sub> <b>Disable</b> Interrupt request is disabled.<br>1 <sub>B</sub> <b>Active</b> Interrupt request is enabled. |
| IR7   | 7    | rw   | <b>Interrupt Enable MGE</b><br>0 <sub>B</sub> <b>Disable</b> Interrupt request is disabled.<br>1 <sub>B</sub> <b>Active</b> Interrupt request is enabled.               |
| IR6   | 6    | rw   | <b>Interrupt Enable xMII</b><br>0 <sub>B</sub> <b>Disable</b> Interrupt request is disabled.<br>1 <sub>B</sub> <b>Active</b> Interrupt request is enabled.              |
| IR5   | 5    | rw   | <b>Interrupt Enable GSWIP</b><br>0 <sub>B</sub> <b>Disable</b> Interrupt request is disabled.<br>1 <sub>B</sub> <b>Active</b> Interrupt request is enabled.             |

**IM0 EINT1 Interrupt Enable Register**

Writing 1 to a bit enables the interrupt request line, while writing 0 to a bit disables the associated interrupt request line.

|  |                         |                         |
|--|-------------------------|-------------------------|
| <b>IM0_EINT1_IER</b>                       | <b>Offset</b>           | <b>Reset Value</b>      |
| <b>IM0 EINT1 Interrupt Enable Register</b> | <b>F3C3<sub>H</sub></b> | <b>0000<sub>H</sub></b> |

|            |  |            |    |            |   |    |   |             |   |             |   |            |   |    |   |  |
|------------|--|------------|----|------------|---|----|---|-------------|---|-------------|---|------------|---|----|---|--|
| 15         |  |            | 12 |            |   | 11 |   | 10          |   | 9           |   | 8          |   |    |   |  |
| <b>Res</b> |  |            |    |            |   |    |   | <b>IR11</b> |   | <b>IR10</b> |   | <b>Res</b> |   |    |   |  |
|            |  |            |    |            |   |    |   | rw          |   | rw          |   |            |   |    |   |  |
| 7          |  |            | 6  |            | 5 |    | 4 |             | 3 |             | 2 |            | 1 |    | 0 |  |
| <b>IR7</b> |  | <b>IR6</b> |    | <b>IR5</b> |   |    |   |             |   | <b>Res</b>  |   |            |   |    |   |  |
| rw         |  | rw         |    | rw         |   | rw |   | rw          |   | rw          |   | rw         |   | rw |   |  |



| Field | Bits | Type | Description   |
|-------|------|------|---|
| IR11  | 11   | rw   | <b>Interrupt Enable SGMII</b><br>0 <sub>B</sub> <b>Disable</b> Interrupt request is disabled.<br>1 <sub>B</sub> <b>Active</b> Interrupt request is enabled.             |
| IR10  | 10   | rw   | <b>Interrupt Enable Packet Extraction</b><br>0 <sub>B</sub> <b>Disable</b> Interrupt request is disabled.<br>1 <sub>B</sub> <b>Active</b> Interrupt request is enabled. |
| IR7   | 7    | rw   | <b>Interrupt Enable MGE</b><br>0 <sub>B</sub> <b>Disable</b> Interrupt request is disabled.<br>1 <sub>B</sub> <b>Active</b> Interrupt request is enabled.               |
| IR6   | 6    | rw   | <b>Interrupt Enable xMII</b><br>0 <sub>B</sub> <b>Disable</b> Interrupt request is disabled.<br>1 <sub>B</sub> <b>Active</b> Interrupt request is enabled.              |
| IR5   | 5    | rw   | <b>Interrupt Enable GSWIP</b><br>0 <sub>B</sub> <b>Disable</b> Interrupt request is disabled.<br>1 <sub>B</sub> <b>Active</b> Interrupt request is enabled.             |

**External Interrupt Control Register**

The edge and level detection mechanism of all external interrupt inputs are controlled by register. The polarity of external interrupt outputs are also controlled by register

| EIU_EXIN_CONF                                     | Offset                  | Reset Value             |           |           |     |      |   |     |      |
|---|-------------------------|-------------------------|-----------|-----------|-----|------|---|-----|------|
| <b>EIU External Interrupt Controller Register</b> | <b>F3C4<sub>H</sub></b> | <b>0000<sub>H</sub></b> |           |           |     |      |   |     |      |
| 15  | 10                      | 9                       | 8         | 7         | 6   | 4    | 3 | 2   | 0    |
| Res   |                         |                         | EOUT<br>1 | EOUT<br>0 | Res | EIN1 |   | Res | EIN0 |
|   |                         |                         | rw        | rw        |     | rw   |   |     | rw   |

| Field | Bits | Type | Description   |
|-------|------|------|---|
| EOUT1 | 9    | rw   | <b>External Interrupt Output EINT1</b><br>Configures the external interrupt pin 1 output characteristics.<br>0 <sub>B</sub> <b>High Level</b> High Active<br>1 <sub>B</sub> <b>Low Level</b> Low Active |
| EOUT0 | 8    | rw   | <b>External Interrupt Output EINT0</b><br>Configures the external interrupt pin 0 output characteristics.<br>0 <sub>B</sub> <b>High Level</b> High Active<br>1 <sub>B</sub> <b>Low Level</b> Low Active |

| <b>Field</b> | <b>Bits</b> | <b>Type</b> | <b>Description</b>  |
|--------------|-------------|-------------|---|
| EIN1         | 6:4         | rw          | <b>External Interrupt Input EINT1</b><br>Configures the external interrupt pin 1 input characteristics.<br>000 <sub>B</sub> <b>Edge/Level</b> Edge and level detection as well as interrupt request generation is disabled<br>001 <sub>B</sub> <b>Rising Edge</b> Interrupt on rising (positive) edges<br>010 <sub>B</sub> <b>Falling Edge</b> Interrupt on falling (negative) edges<br>011 <sub>B</sub> <b>Rising/Falling Edge</b> Both edges, rising and falling edges<br>100 <sub>B</sub> <b>Edge/Level disable</b> Edge and level detection as well as interrupt request generation is disabled<br>101 <sub>B</sub> <b>High Level</b> Level detection of high levels<br>110 <sub>B</sub> <b>Low Level</b> Level detection of low-levels<br>111 <sub>B</sub> <b>Res</b> reserved |
| EIN0         | 2:0         | rw          | <b>External Interrupt Input EINT0</b><br>Configures the external interrupt pin 0 input characteristics.<br>000 <sub>B</sub> <b>Edge/Level</b> Edge and level detection as well as interrupt request generation is disabled<br>001 <sub>B</sub> <b>Rising Edge</b> Interrupt on rising (positive) edges<br>010 <sub>B</sub> <b>Falling Edge</b> Interrupt on falling (negative) edges<br>011 <sub>B</sub> <b>Rising/Falling Edge</b> Both edges, rising and falling edges<br>100 <sub>B</sub> <b>Edge/Level disable</b> Edge and level detection as well as interrupt request generation is disabled<br>101 <sub>B</sub> <b>High Level</b> Level detection of high levels<br>110 <sub>B</sub> <b>Low Level</b> Level detection of low-levels<br>111 <sub>B</sub> <b>Res</b> reserved |

### 4.1.12 LED Registers

This section describes all registers in LED module.

#### LED Single Color Mode Register

This register configures the LED ground mode or power mode.

| LED_MD_CFG                         |              | Offset            |              | Reset Value       |              |             |             |
|------------------------------------|--------------|-------------------|--------------|-------------------|--------------|-------------|-------------|
| LED Single Color LED Mode Register |              | F3E0 <sub>H</sub> |              | 0000 <sub>H</sub> |              |             |             |
| 15                                 | 14           | 13                | 12           | 11                | 10           | 9           | 8           |
| <b>Res</b>                         | <b>LED14</b> | <b>LED13</b>      | <b>LED12</b> | <b>LED11</b>      | <b>LED10</b> | <b>LED9</b> | <b>LED8</b> |
|                                    | rw           | rw                | rw           | rw                | rw           | rw          | rw          |
| 7                                  | 6            | 5                 | 4            | 3                 | 2            | 1           | 0           |
| <b>LED7</b>                        | <b>LED6</b>  | <b>LED5</b>       | <b>LED4</b>  | <b>LED3</b>       | <b>LED2</b>  | <b>LED1</b> | <b>LED0</b> |
| rw                                 | rw           | rw                | rw           | rw                | rw           | rw          | rw          |

| Field | Bits | Type | Description  |
|-------|------|------|--|
| LED14 | 14   | rw   | <b>LED Single Color Mode</b><br>0 <sub>B</sub> <b>Ground</b> LED Single Color Ground Mode<br>1 <sub>B</sub> <b>Power</b> LED Single Color Power Mode |
| LED13 | 13   | rw   | <b>LED Single Color Mode</b><br>0 <sub>B</sub> <b>Ground</b> LED Single Color Ground Mode<br>1 <sub>B</sub> <b>Power</b> LED Single Color Power Mode |
| LED12 | 12   | rw   | <b>LED Single Color Mode</b><br>0 <sub>B</sub> <b>Ground</b> LED Single Color Ground Mode<br>1 <sub>B</sub> <b>Power</b> LED Single Color Power Mode |
| LED11 | 11   | rw   | <b>LED Single Color Mode</b><br>0 <sub>B</sub> <b>Ground</b> LED Single Color Ground Mode<br>1 <sub>B</sub> <b>Power</b> LED Single Color Power Mode |
| LED10 | 10   | rw   | <b>LED Single Color Mode</b><br>0 <sub>B</sub> <b>Ground</b> LED Single Color Ground Mode<br>1 <sub>B</sub> <b>Power</b> LED Single Color Power Mode |
| LED9  | 9    | rw   | <b>LED Single Color Mode</b><br>0 <sub>B</sub> <b>Ground</b> LED Single Color Ground Mode<br>1 <sub>B</sub> <b>Power</b> LED Single Color Power Mode |
| LED8  | 8    | rw   | <b>LED Single Color Mode</b><br>0 <sub>B</sub> <b>Ground</b> LED Single Color Ground Mode<br>1 <sub>B</sub> <b>Power</b> LED Single Color Power Mode |
| LED7  | 7    | rw   | <b>LED Single Color Mode</b><br>0 <sub>B</sub> <b>Ground</b> LED Single Color Ground Mode<br>1 <sub>B</sub> <b>Power</b> LED Single Color Power Mode |

**Registers**

| <b>Field</b> | <b>Bits</b> | <b>Type</b> | <b>Description</b>   |
|--------------|-------------|-------------|--|
| LED6         | 6           | rw          | <b>LED Single Color Mode</b><br>0 <sub>B</sub> <b>Ground</b> LED Single Color Ground Mode<br>1 <sub>B</sub> <b>Power</b> LED Single Color Power Mode |
| LED5         | 5           | rw          | <b>LED Single Color Mode</b><br>0 <sub>B</sub> <b>Ground</b> LED Single Color Ground Mode<br>1 <sub>B</sub> <b>Power</b> LED Single Color Power Mode |
| LED4         | 4           | rw          | <b>LED Single Color Mode</b><br>0 <sub>B</sub> <b>Ground</b> LED Single Color Ground Mode<br>1 <sub>B</sub> <b>Power</b> LED Single Color Power Mode |
| LED3         | 3           | rw          | <b>LED Single Color Mode</b><br>0 <sub>B</sub> <b>Ground</b> LED Single Color Ground Mode<br>1 <sub>B</sub> <b>Power</b> LED Single Color Power Mode |
| LED2         | 2           | rw          | <b>LED Single Color Mode</b><br>0 <sub>B</sub> <b>Ground</b> LED Single Color Ground Mode<br>1 <sub>B</sub> <b>Power</b> LED Single Color Power Mode |
| LED1         | 1           | rw          | <b>LED Single Color Mode</b><br>0 <sub>B</sub> <b>Ground</b> LED Single Color Ground Mode<br>1 <sub>B</sub> <b>Power</b> LED Single Color Power Mode |
| LED0         | 0           | rw          | <b>LED Single Color Mode</b><br>0 <sub>B</sub> <b>Ground</b> LED Single Color Ground Mode<br>1 <sub>B</sub> <b>Power</b> LED Single Color Power Mode |

**LED Brightness Control Register**

This register configures the LED brightness control.

| LED_BRT_CTRL                    |             | Offset            |                 | Reset Value       |   |
|---------------------------------|-------------|-------------------|-----------------|-------------------|---|
| LED Brightness Control Register |             | F3E1 <sub>H</sub> |                 | F430 <sub>H</sub> |   |
| 15                              | 12          | 11                | 8               |                   |   |
| <b>MAXLEVEL</b>                 |             |                   | <b>MINLEVEL</b> |                   |   |
| rw                              |             |                   | rw              |                   |   |
| 7                               | 6           | 5                 | 4               | 3                 | 0 |
| <b>Res</b>                      | <b>EDGE</b> | <b>EN</b>         | <b>2SEWN</b>    | <b>Res</b>        |   |
|                                 | rw          | rw                | rw              |                   |   |

| Field    | Bits  | Type | Description   |
|----------|-------|------|---|
| MAXLEVEL | 15:12 | rw   | <b>Maximum LED Brightness Value</b>   |
| MINLEVEL | 11:8  | rw   | <b>Minimum LED Brightness Value</b>   |
| EDGE     | 6     | rw   | <b>LED Brightness Switch Edge Detection</b><br>0 <sub>B</sub> <b>Falling</b> Falling Edge<br>1 <sub>B</sub> <b>Rising</b> Rising Edge   |
| EN       | 5     | rw   | <b>LED Brightness Control Enable</b><br>0 <sub>B</sub> <b>Disable</b> LED brightness control is disabled<br>1 <sub>B</sub> <b>Enable</b> LED brightness control is enabled  |
| 2SEWN    | 4     | rw   | <b>LED Brightness 2 Level Switch Enable</b><br>0 <sub>B</sub> <b>Disable</b> LED brightness control via an external switch is disabled<br>1 <sub>B</sub> <b>Enable</b> LED brightness control via an external switch is enabled |

**LED Light Sensing Control Register**

This register configures the LED light sensing.

| LED_LSENS_CTRL                     |    | Offset            |               | Reset Value       |  |
|------------------------------------|----|-------------------|---------------|-------------------|--|
| LED Light Sensing Control Register |    | F3E2 <sub>H</sub> |               | 0D09 <sub>H</sub> |  |
| 15                                 | 14 | 13                | 8             |                   |  |
| <b>Res</b>                         |    | <b>TD</b>         |               |                   |  |
|                                    |    | rw                |               |                   |  |
| 7                                  | 4  | 3                 | 2             | 0                 |  |
| <b>CURLEVEL</b>                    |    | <b>SENS</b>       | <b>PERIOD</b> |                   |  |
| rw                                 |    | rw                | rw            |                   |  |

| Field    | Bits | Type | Description   |
|----------|------|------|---|
| TD       | 13:8 | rw   | <b>The Number of Slots for Discharge</b>  |
| CURLEVEL | 7:4  | rh   | <b>Current Brightness Level</b>   |
| SENS     | 3    | rw   | <b>LED Sensing Enable</b><br>0 <sub>B</sub> <b>Disable</b> LED sensing is disabled<br>1 <sub>B</sub> <b>Enable</b> LED sensing is enabled   |
| PERIOD   | 2:0  | rw   | <b>LED Sensing Period</b><br>000 <sub>B</sub> <b>1000</b> 1000 ms<br>001 <sub>B</sub> <b>500</b> 500 ms<br>010 <sub>B</sub> <b>333</b> 333 ms<br>011 <sub>B</sub> <b>250</b> 250 ms<br>100 <sub>B</sub> <b>200</b> 200 ms<br>101 <sub>B</sub> <b>167</b> 167 ms<br>110 <sub>B</sub> <b>142</b> 142 ms<br>111 <sub>B</sub> <b>125</b> 125 ms |

## 4.2 SGMII\_Registers

This section defines all the registers required to operate the SGMII module.

**Table 56 Registers Address Space**

| Module      | Base Address     | End Address      | Note |
|-------------|------------------|------------------|------|
| SGMII_TBI   | 300 <sub>H</sub> | 3FF <sub>H</sub> |      |
| SGMII_PCS   | 400 <sub>H</sub> | 4FF <sub>H</sub> |      |
| SGMII_PHY   | 000 <sub>H</sub> | 1FF <sub>H</sub> |      |
| SGMII_MACRO | 200 <sub>H</sub> | 2FF <sub>H</sub> |      |

**Table 57 Registers Overview**

| Register Short Name  | Register Long Name                             | Offset Address    | Page Number         |
|--|--|-------------------|---------------------|
| <b>SGMII_Registers, SGMII_TBI: TBI Submodule Register File</b> |  |                   |                     |
| <a href="#">SGMII_TBI_TXANEGH</a>                              | SGMII Transmit Auto-Negotiation High Byte      | D300 <sub>H</sub> | <a href="#">226</a> |
| <a href="#">SGMII_TBI_TXAN EGL</a>                             | SGMII Transmit Auto-Negotiation Low Byte       | D301 <sub>H</sub> | <a href="#">227</a> |
| <a href="#">SGMII_TBI_RXANEGH</a>                              | SGMII Receive Auto-Negotiation High Byte(15:8) | D302 <sub>H</sub> | <a href="#">228</a> |
| <a href="#">SGMII_TBI_RXAN EGL</a>                             | SGMII Receive Auto-Negotiation Low Byte(7:0)   | D303 <sub>H</sub> | <a href="#">229</a> |
| <a href="#">SGMII_TBI_ANEGCTL</a>                              | SGMII Auto-Negotiation Control Bits            | D304 <sub>H</sub> | <a href="#">230</a> |
| <a href="#">SGMII_TBI_TBICTL</a>                               | SGMII TBI Control Bits                         | D305 <sub>H</sub> | <a href="#">232</a> |
| <a href="#">SGMII_TBI_TBICTL T</a>                             | SGMII TBI Control Bits TX                      | D306 <sub>H</sub> | <a href="#">234</a> |
| <a href="#">SGMII_TBI_TBITEST</a>                              | SGMII TBI Test Control Bits                    | D307 <sub>H</sub> | <a href="#">235</a> |
| <a href="#">SGMII_TBI_RXERR</a>                                | SGMII RX Error Counter                         | D308 <sub>H</sub> | <a href="#">236</a> |
| <a href="#">SGMII_TBI_TBISTAT</a>                              | SGMII TBI Status                               | D309 <sub>H</sub> | <a href="#">237</a> |
| <a href="#">SGMII_TBI_LPSTAT</a>                               | SGMII Link Partner Status                      | D30A <sub>H</sub> | <a href="#">238</a> |
| <a href="#">SGMII_TBI_ISTAT</a>                                | SGMII Interrupt Status                         | D30B <sub>H</sub> | <a href="#">239</a> |
| <a href="#">SGMII_TBI_IMASK</a>                                | SGMII Interrupt Mask                           | D30C <sub>H</sub> | <a href="#">240</a> |
| <a href="#">SGMII_TBI_TX_FSM_S<br/>TAT</a>                     | SGMII Transmitter State                        | D30D <sub>H</sub> | <a href="#">241</a> |
| <a href="#">SGMII_TBI_RX_FSM_S<br/>TAT</a>                     | SGMII Receiver State                           | D30E <sub>H</sub> | <a href="#">242</a> |
| <b>SGMII_Registers, SGMII_PCS: SGMII PCS Register File</b>     |  |                   |                     |
| <a href="#">SGMII_PCS_CFG</a>                                  | SGMII PCS Configuration                        | D400 <sub>H</sub> | <a href="#">243</a> |
| <a href="#">SGMII_PCS_RXB_CTL</a>                              | SGMII Receive Buffer Control                   | D401 <sub>H</sub> | <a href="#">244</a> |
| <a href="#">SGMII_PCS_RXB_CFG</a>                              | SGMII Receive Buffer Configuration             | D402 <sub>H</sub> | <a href="#">245</a> |
| <a href="#">SGMII_PCS_RXB_STA<br/>T</a>                        | SGMII PCS Receive Buffer Status                | D403 <sub>H</sub> | <a href="#">246</a> |
| <a href="#">SGMII_PCS_TXB_CTL</a>                              | SGMII PCS Transmit Buffer Control              | D404 <sub>H</sub> | <a href="#">247</a> |
| <a href="#">SGMII_PCS_TXB_CFG</a>                              | SGMII PCS Transmit Buffer Configuration        | D405 <sub>H</sub> | <a href="#">248</a> |
| <a href="#">SGMII_PCS_TXB_STA<br/>T</a>                        | SGMII PCS Transmit Buffer Status               | D406 <sub>H</sub> | <a href="#">249</a> |
| <b>SGMII_Registers, SGMII_PHY: SGMII_PHY Registers</b>         |  |                   |                     |

**Table 57 Registers Overview (cont'd)**

| Register Short Name  | Register Long Name         | Offset Address    | Page Number         |
|--|----------------------------|-------------------|---------------------|
| <a href="#">SGMII_PHY_RESETN</a>                                     | SGMII PHY Reset            | D000 <sub>H</sub> | <a href="#">250</a> |
| <a href="#">SGMII_PHY_MPLL_CFG1</a>                                  | SGMII PHY MPLL CFG1        | D001 <sub>H</sub> | <a href="#">251</a> |
| <a href="#">SGMII_PHY_MPLL_CFG2</a>                                  | SGMII PHY MPLL CFG2        | D002 <sub>H</sub> | <a href="#">252</a> |
| <a href="#">SGMII_PHY_RX0_CFG1</a>                                   | SGMII PHY RX0 CFG1         | D003 <sub>H</sub> | <a href="#">253</a> |
| <a href="#">SGMII_PHY_RX0_CFG2</a>                                   | SGMII PHY RX0 CFG2         | D004 <sub>H</sub> | <a href="#">254</a> |
| <a href="#">SGMII_PHY_TX0_CFG1</a>                                   | SGMII PHY TX0 CFG1         | D005 <sub>H</sub> | <a href="#">255</a> |
| <a href="#">SGMII_PHY_TX0_CFG2</a>                                   | SGMII PHY TX0 CFG2         | D006 <sub>H</sub> | <a href="#">256</a> |
| <a href="#">SGMII_PHY_TX0_CFG3</a>                                   | SGMII PHY TX0 CFG3         | D007 <sub>H</sub> | <a href="#">257</a> |
| <a href="#">SGMII_PHY_MISC</a>                                       | SGMII PHY MISC             | D008 <sub>H</sub> | <a href="#">258</a> |
| <a href="#">SGMII_PHY_HWBU_CTRL</a>                                  | SGMII PHY HWBU CTRL        | D009 <sub>H</sub> | <a href="#">259</a> |
| <a href="#">SGMII_PHY_STATUS</a>                                     | SGMII PHY STATUS           | D00A <sub>H</sub> | <a href="#">260</a> |
| <a href="#">SGMII_PHY_D</a>  | SGMII PHY D                | D100 <sub>H</sub> | <a href="#">261</a> |
| <a href="#">SGMII_PHY_A</a>  | SGMII PHY A                | D101 <sub>H</sub> | <a href="#">262</a> |
| <a href="#">SGMII_PHY_C</a>  | SGMII PHY C                | D102 <sub>H</sub> | <a href="#">263</a> |
| <a href="#">SGMII_PHY_WATCHDOG_CTRL</a>                              | SGMII PHY WATCHDOG CONTROL | D111 <sub>H</sub> | <a href="#">264</a> |
| <a href="#">SGMII_PHY_WATCHDOG_TIMER</a>                             | SGMII PHY WATCHDOG TIMER   | D112 <sub>H</sub> | <a href="#">264</a> |
| <b>SGMII_Registers, SGMII_MACRO_REGISTERS: SGMII_MACRO Registers</b> |                            |                   |                     |
| <a href="#">SGMII_MACRO_SGMII_CTRL1</a>                              | SGMII Macro SGMII CTRL1    | D201 <sub>H</sub> | <a href="#">266</a> |
| <a href="#">SGMII_MACRO_CLK_CTRL</a>                                 | SGMII Macro Clock Control  | D20F <sub>H</sub> | <a href="#">267</a> |
| <a href="#">SGMII_MACRO_RESETN</a>                                   | SGMII Macro Reset Control  | D200 <sub>H</sub> | <a href="#">265</a> |

The register is addressed wordwise.



**Table 58 Register Access Types**

| <b>Mode</b>  | <b>Symbol</b> |
|--|---------------|
| Interrupt status register, latching high, cleared by writing a ONE | lhsc          |
| Hardware status, read-only   | rh            |
| Read/write register with input from and output to hardware         | rwh           |
| Standard read/write register with output to hardware               | rw            |

#### 4.2.1 SGMII\_TBI: TBI Submodule Register File

This section defines all the registers required to operate the SGMII\_TBI module.<sup>1)</sup>

##### SGMII Transmit Auto-Negotiation High Byte

This register holds the part of the control word transmitted during ANEG.

| SGMII_TBI_TXANEG                          | Offset            | Reset Value       |
|---|-------------------|-------------------|
| SGMII Transmit Auto-Negotiation High Byte | D300 <sub>H</sub> | 0000 <sub>H</sub> |
| 15  |                   | 8                 |
| Res                                       |                   |                   |
| 7   | 6                 | 5                 |
|   |                   | 0                 |
| NP  | Res               | DATAH             |
| rw  |                   | rw                |

| Field | Bits | Type | Description  |
|-------|------|------|--|
| NP    | 7    | rw   | <b>Next Page</b><br>The NP bit is set up the external Next Page function to indicate whether or not this is the last page to be transmitted<br>0 <sub>B</sub> <b>LAST</b> Last Page<br>1 <sub>B</sub> <b>NEXT</b> Additional next page to follow |
| DATAH | 5:0  | rw   | <b>Higher Data or Control Bits for Auto-Negotiation</b><br>This is the upper byte of the transmitted control word during ANEG  |

1) Generated by REFIGE v1.4 - Beta Release XIV

**SGMII Transmit Auto-Negotiation Low Byte**

This register holds part of the control word transmitted during ANEG.

| SGMII_TBI_TXANEGH                         | Offset            | Reset Value       |
|---|-------------------|-------------------|
| SGMII Transmit Auto-Negotiation High Byte | D301 <sub>H</sub> | 0000 <sub>H</sub> |
| 15  |                   | 8                 |
| Res                                       |                   |                   |
| 7   |                   | 0                 |
| DATAL                                     |                   |                   |
| rw  |                   |                   |

| Field | Bits | Type | Description   |
|-------|------|------|---|
| DATAL | 7:0  | rw   | <b>Lower Data or Control Bits for Auto-Negotiation</b><br>The SGMII_TBI_TXANEGH must be written after SGMII_TBI_TXANEGH. Writing to SGMII_TBI_TXANEGH register updates the tx_config_reg(15:0) (described in cl 36 of the standard). When Next Page function is supported, the controller must write to NP bit in SGMII_TBI_TXANEGH to go to NEXT_PAGE_WAIT state in ANEG FSM after ANEG Interrupt. |

**SGMII Receive Auto-Negotiation High Byte(15:8)**

This register holds part of the control word received during ANEG.

| SGMII_TBI_RXANEGH                                     | Offset                  | Reset Value             |
|---|-------------------------|-------------------------|
| <b>SGMII Receive Auto-Negotiation High Byte(15:8)</b> | <b>D302<sub>H</sub></b> | <b>0000<sub>H</sub></b> |
| 15  |                         | 8                       |
| <b>Res</b>  |                         |                         |
| 7   | 6                       | 5                       |
| <b>NP</b>   | <b>ACK</b>              | <b>DATAH</b>            |
| rh  | rh                      | rh                      |

| Field | Bits | Type | Description  |
|-------|------|------|--|
| NP    | 7    | rh   | <b>Next Page</b><br>The NP bit is used by the Next Page function to indicate whether or not this is the last page<br>0 <sub>B</sub> <b>LAST</b> Last Page<br>1 <sub>B</sub> <b>NEXT</b> Additional next page to follow |
| ACK   | 6    | rh   | <b>Acknowledge</b><br>0 <sub>B</sub> <b>NAK</b> No Acknowledge received<br>1 <sub>B</sub> <b>ACK</b> Acknowledge received  |
| DATAH | 5:0  | rh   | <b>Higher Data or Control Bits for Auto-Negotiation</b><br>This is the upper byte of the received control word during ANEG   |

**SGMII Receive Auto-Negotiation Low Byte(7:0)**

This register holds part of the control word received during ANEG.

| SGMII_TBI_RXANEG_L                           | Offset            | Reset Value       |
|--|-------------------|-------------------|
| SGMII Receive Auto-Negotiation Low Byte(7:0) | D303 <sub>H</sub> | 0000 <sub>H</sub> |

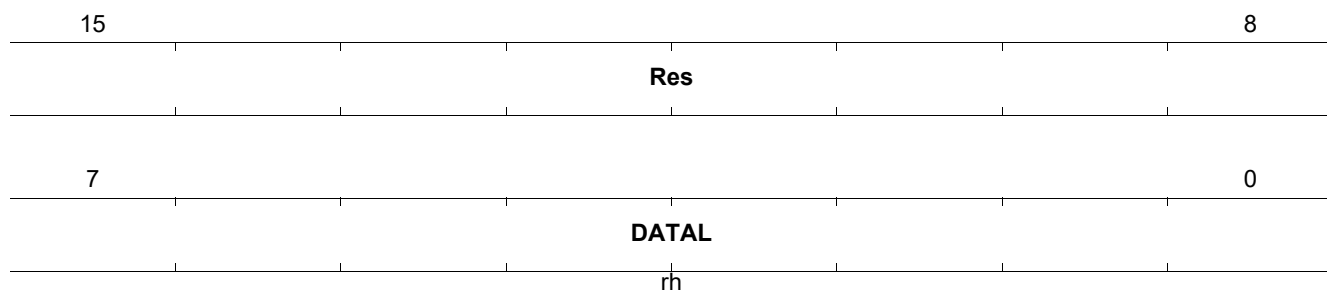

| Field | Bits | Type | Description   |
|-------|------|------|---|
| DATAL | 7:0  | rh   | <b>Lower Data or Control Bits for Auto-Negotiation</b><br>This is the lower byte of the received control word during ANEG |

**SGMII Auto-Negotiation Control Bits**

This register holds the bits that control the ANEG process.

| SGMII_TBI_ANEGCTL                   |    | Offset            |               | Reset Value       |               |           |   |
|-------------------------------------|----|-------------------|---------------|-------------------|---------------|-----------|---|
| SGMII Auto-Negotiation Control Bits |    | D304 <sub>H</sub> |               | 00B2 <sub>H</sub> |               |           |   |
| 15                                  | 14 |                   |               |                   |               | 8         |   |
| <b>BCOMP</b>                        |    | <b>Res</b>        |               |                   |               |           |   |
| rw                                  |    |                   |               |                   |               |           |   |
| 7                                   | 6  | 5                 | 4             | 3                 | 2             | 1         | 0 |
| <b>ANMODE</b>                       |    | <b>OVRANEG</b>    | <b>OVRABL</b> | <b>RANEG</b>      | <b>ANEGEN</b> | <b>LT</b> |   |
| rw                                  |    | rw                | rw            | rwh               | rw            | rw        |   |

| Field   | Bits | Type | Description  |
|---------|------|------|--|
| BCOMP   | 15   | rw   | <b>Backwards Compatibility Control</b><br>ANEG FSM switches from COMPLETE_ACKNOWLEDGE to NEXT_PAGE_WAIT only when LP's NP ability is activated (among other conditions).<br>Retains earlier ANEG FSM operating mode, where LP's NP ability is not considered in changing state COMPLETE_ACKNOWLEDGE to NEXT_PAGE_WAIT state.<br>0 <sub>B</sub> <b>INCOMP</b> Backwards incompatible mode<br>1 <sub>B</sub> <b>COMP</b> Backwards compatible mode |
| ANMODE  | 7:6  | rw   | <b>ANEG Mode</b><br>00 <sub>B</sub> <b>RESERVED</b> RESERVED<br>01 <sub>B</sub> <b>SGMII_1000BX</b> 1000BASE-X mode: ANEG done as defined by 1000BASE-X.<br>10 <sub>B</sub> <b>SGMII_PHY</b> SGMII PHY mode: ANEG done as defined by SGMII standard, as PHY.<br>11 <sub>B</sub> <b>SGMII_MAC</b> SGMII MAC mode: ANEG done as defined by SGMII standard, as MAC.   |
| OVRANEG | 5    | rw   | <b>Override Ability for ANEG Control</b><br>0 <sub>B</sub> <b>HW_INT</b> Hardware mode: ANEG Mode, Enable ANEG and restart ANEG are taken from interface signals AN_MODE_I, AN_EN_I and AN_RS_I respectively<br>1 <sub>B</sub> <b>OVERRIDE</b> Register Mode: ANEG Mode, Enable ANEG and restart ANEG are taken from bits ANMODE, ANEGEN, RANEG of this register   |

| Field  | Bits | Type | Description   |
|--------|------|------|---|
| OVRABL | 4    | rw   | <p><b>Override Ability for tx_config_reg</b><br/>           Ability values are taken from Hardware Interface<br/>           SGMII (PHY mode only): AN_FD_I and AN_HD_I to form duplex mode bit; TR_DR_I to form speed bit<br/>           1000BASE-X: AN_FD_I and AN_HD_I to form FD and HD bits; AN_PS_I form PS1 and PS2 bits; AN_RF_I form RF1 and RF2 bits<br/>           Note: Other tx_config_reg bits are set to '0' in this mode<br/>           The tx_config_reg values are taken from Register TXANEGH and TXANEGL</p> <p>0<sub>B</sub> <b>HW_INT</b> Hardware mode: Ability Values are taken from Interface Signals<br/>           1<sub>B</sub> <b>OVERRIDE</b> Register Mode: Override, Ability Values are taken from Registers</p> |
| RANEG  | 3    | rwh  | <p><b>Restart Auto-Negotiation Process</b><br/>           Bit is cleared by hardware after FSM restarts.</p> <p>0<sub>B</sub> <b>NORMAL</b> Normal operation<br/>           1<sub>B</sub> <b>RESTART</b> Restart auto-negotiation process</p>   |
| ANEGEN | 2    | rw   | <p><b>Auto-Negotiation Enable</b><br/>           Enable auto-negotiation for TBI Interface.</p> <p>0<sub>B</sub> <b>DISABLE</b> Auto-negotiation is disabled<br/>           1<sub>B</sub> <b>ENABLE</b> Auto-negotiation is enabled</p>   |
| LT     | 1:0  | rw   | <p><b>Link Timer Value</b><br/>           Link timer values for TBI ANEG FSM. Required value for standard TBI is 10 ms. Required value for SGMII is 1.6 ms (Reset value).</p> <p>00<sub>B</sub> <b>T_10US</b> Timer Delay is 10 μs (Simulation)<br/>           01<sub>B</sub> <b>T_1_6MS</b> Timer Delay is 1.6 ms (SGMII)<br/>           10<sub>B</sub> <b>T_5MS</b> Timer Delay is 5 ms<br/>           11<sub>B</sub> <b>T_10MS</b> Timer Delay is 10 ms (TBI)</p>  |

**SGMII TBI Control Bits**

This register holds the bits that control the TBI operations.

| SGMII_TBI_TBICTL       | Offset            | Reset Value       |               |            |             |              |               |
|------------------------|-------------------|-------------------|---------------|------------|-------------|--------------|---------------|
| SGMII TBI Control Bits | D305 <sub>H</sub> | 0001 <sub>H</sub> |               |            |             |              |               |
| 15                     |                   | 8                 |               |            |             |              |               |
| Res                    |                   |                   |               |            |             |              |               |
| 7                      | 6                 | 5                 | 4             | 3          | 2           | 1            | 0             |
| <b>RVBO</b>            | <b>RVBI</b>       | <b>CRSOFF</b>     | <b>CRSTRR</b> | <b>RPM</b> | <b>LPB1</b> | <b>ENTBI</b> | <b>INITBI</b> |
| rw                     | rw                | rw                | rw            | rw         | rw          | rw           | rw            |

| Field  | Bits | Type | Description   |
|--------|------|------|---|
| RVBO   | 7    | rw   | <b>Reverse Bit Order Output</b><br>Output of 10 Bit encoder is (9:0) or (0:9)<br>0 <sub>B</sub> <b>NORMAL</b> 10 Bit Output according to Standard<br>1 <sub>B</sub> <b>REVERS</b> 10 Bit Output with reversed Bit Order   |
| RVBI   | 6    | rw   | <b>Reverse Bit Order Input</b><br>Input for 10 Bit decoder is (9:0) or (0:9)<br>0 <sub>B</sub> <b>NORMAL</b> 10 Bit Input according to Standard<br>1 <sub>B</sub> <b>REVERS</b> 10 Bit Input with reversed Bit Order  |
| CRSOFF | 5    | rw   | <b>Carrier Sense Off</b><br>CRS output on GMII interface can be switched off especially for device which have trouble with that in Half Duplex mode .<br>0 <sub>B</sub> <b>ON</b> Carrier Sense is always generated in HD and FD<br>1 <sub>B</sub> <b>OFF</b> Carrier Sense is never generated, forced to 0                                   |
| CRSTRR | 4    | rw   | <b>Carrier Sense Extension for Sequence T/R/R/K28.5</b><br>Select Generation of Carrier Extension in Case of TBI Sequence /T/R/R/K28.5 according to Figure 36-7b of IEEE Std 802.3.<br>0 <sub>B</sub> <b>NO</b> No Generate Carrier Extension<br>1 <sub>B</sub> <b>YES</b> Generate Carrier Extension   |
| RPM    | 3    | rw   | <b>Repeater Mode of TBI</b><br>Enable Repeater Operation for TBI Interface.<br>Repeater Mode: CRS is only asserted in response to receive activity.<br>Normal Operation: CRS is asserted in response to either transmit ore receive.<br>0 <sub>B</sub> <b>NORMAL</b> Normal operation<br>1 <sub>B</sub> <b>REPEATER</b> Repeater mode enabled |



| Field   | Bits | Type | Description   |
|---------|------|------|---|
| LPB1    | 2    | rw   | <b>Loopback Mode of TBI</b><br>Enable Digital Loopback Operation. NOTE: For proper loopback operation, in addition to setting this bit, the digital loop in the PMA must be activated. For this, it is required to set the following bits in the PMA: en_txilpbk and rxlbi_en. See the SYNOPSIS* documentation for further information.<br>0 <sub>B</sub> <b>NORMAL</b> Normal operation<br>1 <sub>B</sub> <b>LOOPBACK</b> Loopback enabled |
| ENTBI   | 1    | rw   | <b>Enable of TBI Interface</b><br>Set to 1 for normal TBI operation, when set to DISABLE the RX and TX FSMs are frozen.<br>0 <sub>B</sub> <b>DISABLE</b> TBI Interface is disabled<br>1 <sub>B</sub> <b>ENABLE</b> TBI Interface is enabled   |
| INITTBI | 0    | rw   | <b>Reset of TBI FSM</b><br>Reset TBI Interface.<br>0 <sub>B</sub> <b>NORMAL</b> Normal operation<br>1 <sub>B</sub> <b>INIT</b> Initialization of TBI  |

**SGMII TBI Control Bits TX**

This register holds the bits that control the TBI operations.

| SGMII_TBI_TBICTLT         | Offset            | Reset Value       |
|---------------------------|-------------------|-------------------|
| SGMII TBI Control Bits TX | D306 <sub>H</sub> | 0000 <sub>H</sub> |
| 15                        |                   | 8                 |
| Res                       |                   |                   |
| 7                         |                   | 0                 |
| Res                       |                   | TXFS              |
| rw                        |                   |                   |

| Field | Bits | Type | Description   |
|-------|------|------|---|
| TXFS  | 0    | rw   | <p><b>Transmit False Carrier Insertion</b></p> <p>When enabled, defines a non-standard TX_FLASE_CARRIER state in PCS transmit ordered_set FSM in between XMIT_DATA and START_OF_PACKET states, which is entered in case TX_EN_I = '0' and TX_ER_I = '1'. See Figure 36-5 of IEEE Std 802.3.</p> <p>0<sub>B</sub> <b>NO</b> No False Carrier Insertion</p> <p>1<sub>B</sub> <b>YES</b> False Carrier Insertion</p> |

**SGMII TBI Test Control Bits**

This register holds the bits to enable some test features of the TBI.

|                                    |                         |                         |
|------------------------------------|-------------------------|-------------------------|
| <b>SGMII_TBI_TBITEST</b>           | <b>Offset</b>           | <b>Reset Value</b>      |
| <b>SGMII TBI Test Control Bits</b> | <b>D307<sub>H</sub></b> | <b>0000<sub>H</sub></b> |

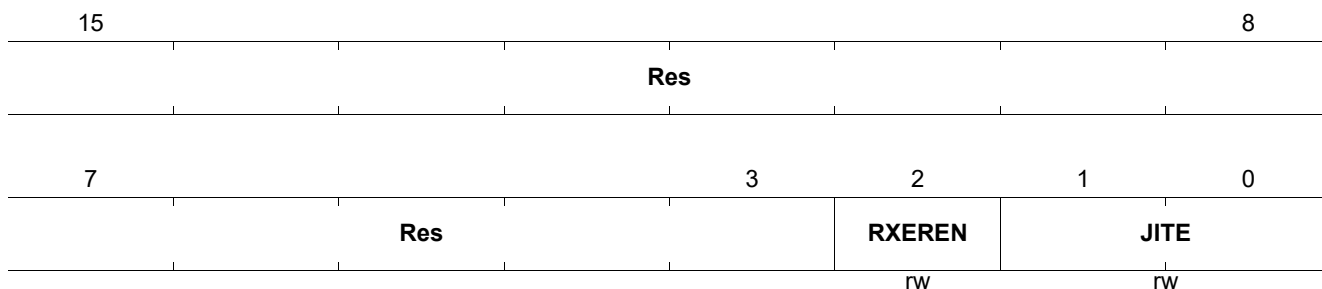

| Field  | Bits | Type | Description  |
|--------|------|------|--|
| RXEREN | 2    | rw   | <b>Enable RX Error Counter</b><br>When enabled, the errors from 8b10b Decoder are counted<br>0 <sub>B</sub> <b>DSIABLE</b> RX Error Counter is disabled<br>1 <sub>B</sub> <b>ENABLE</b> RX Error Counter is enabled  |
| JITE   | 1:0  | rw   | <b>Jitter Test pattern for Transmit</b><br>When set, the test pattern according to IEEE Std 802.3 chapter 36 A are transmitted.<br>00 <sub>B</sub> <b>NO</b> Normal Function<br>01 <sub>B</sub> <b>HIGH</b> Transmit High Frequency test pattern 36A.1<br>10 <sub>B</sub> <b>LOW</b> Transmit Low Frequency test pattern 36A.2<br>11 <sub>B</sub> <b>MIXED</b> Transmit Mixed Frequency test pattern 36A.3 |

**SGMII RX Error Counter**

This register holds the count of errors as seen by the 8b10b decoder.

| SGMII_TBI_RXERR        | Offset            | Reset Value       |
|------------------------|-------------------|-------------------|
| SGMII RX Error Counter | D308 <sub>H</sub> | 0000 <sub>H</sub> |
| 15                     |                   | 8                 |
|                        | Res               |                   |
| 7                      |                   | 0                 |
|                        | RXERRC            |                   |
|                        | rwh               |                   |

| Field  | Bits | Type | Description  |
|--------|------|------|--|
| RXERRC | 7:0  | rwh  | <b>RX Error Counter</b><br>When enabled the receive errors detected by the 8b10b Decoder are counted. The register is cleared by read. |

**SGMII TBI Status**

This register holds the status bits of the TBI FSMs.

|                          |                         |                         |
|--------------------------|-------------------------|-------------------------|
| <b>SGMII_TBI_TBISTAT</b> | <b>Offset</b>           | <b>Reset Value</b>      |
| <b>SGMII TBI Status</b>  | <b>D309<sub>H</sub></b> | <b>0000<sub>H</sub></b> |

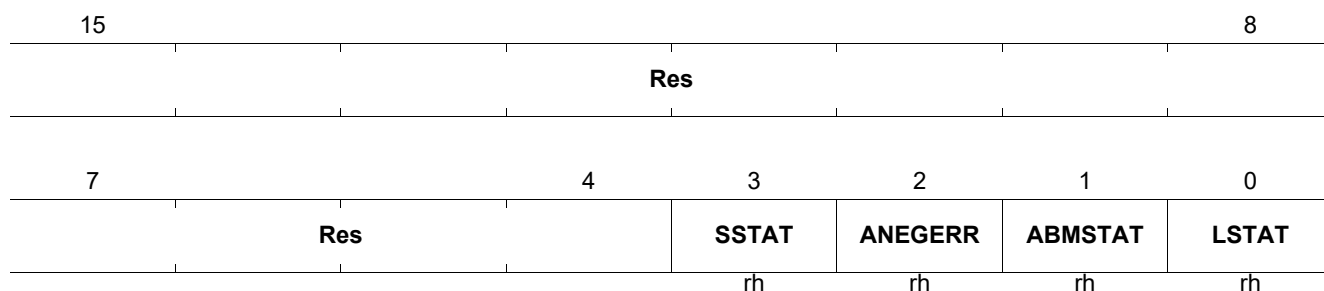

| Field   | Bits | Type | Description   |
|---------|------|------|---|
| SSTAT   | 3    | rh   | <b>Sync Status of the TBI Sync FSM</b><br>Status of the TBI Sync FSM as defined in figure 36-9 of 802.3<br>0 <sub>B</sub> <b>NOK</b> Sync Status of TBI is not OK<br>1 <sub>B</sub> <b>OK</b> Sync Status of TBI is OK  |
| ANEGERR | 2    | rh   | <b>Auto-Negotiation Error</b><br>Error Bit set when Abilities of local device and link partner do not match and cannot be resolved by the RESOLVE_PRIORIY function during auto-negotiation, when auto-negotiation is enabled. Not valid for SGMII mode.<br>0 <sub>B</sub> <b>NO_ERROR</b> No auto-negotiation error<br>1 <sub>B</sub> <b>ERROR</b> Auto-negotiation Error |
| ABMSTAT | 1    | rh   | <b>Ability Match of TBI</b><br>Ability match status when auto-negotiation is enabled.<br>0 <sub>B</sub> <b>NOK</b> Auto-negotiation State Machine ability does not match<br>1 <sub>B</sub> <b>OK</b> Auto-negotiation State Machine ability match   |
| LSTAT   | 0    | rh   | <b>Link Status of TBI</b><br>Indicates whether the ANEG FSM advanced to the LINK_OK status or not when auto-negotiation is enabled<br>0 <sub>B</sub> <b>NOK</b> Auto-negotiation State Machine is not in LINK_OK state<br>1 <sub>B</sub> <b>OK</b> Auto-negotiation State Machine is in LINK_OK state   |

**SGMII Link Partner Status**

This register carries information about the link partner obtained via ANEG.

| SGMII_TBI_LPSTAT                 | Offset                  | Reset Value             |
|----------------------------------|-------------------------|-------------------------|
| <b>SGMII Link Partner Status</b> | <b>D30A<sub>H</sub></b> | <b>0000<sub>H</sub></b> |
| 15                               |                         | 8                       |
| <b>Res</b>                       |                         |                         |
| 7                                | 6                       | 5                       |
| 4                                | 3                       | 2                       |
| 1                                | 0                       |                         |
| <b>Res</b>                       | <b>DR</b>               | <b>RF</b>               |
|                                  | <b>PS</b>               | <b>DPX</b>              |
|                                  | rwh                     | rwh                     |
|                                  | rwh                     | rwh                     |

| Field | Bits | Type | Description   |
|-------|------|------|---|
| DR    | 6:5  | rwh  | <b>SGMII Data Rate</b><br>SGMII Data Rate at link partner, set by HW when OVRABL is DISABLED and ANEG is enabled by HW or SW, only valid in SGMII Mode<br>00 <sub>B</sub> <b>DR10</b> Data Rate is 10 Mbps<br>01 <sub>B</sub> <b>DR100</b> Data Rate is 100 Mbps<br>10 <sub>B</sub> <b>DR1000</b> Data Rate is 1000 Mbps<br>11 <sub>B</sub> <b>INVALID</b> Not SGMII Mode   |
| RF    | 4:3  | rwh  | <b>Remote Fault</b><br>Remote Fault Status at link partner, set by HW when OVRABL is DISABLED and ANEG is enabled by HW or SW<br>00 <sub>B</sub> <b>LINK_OK</b> No Error, link OK<br>01 <sub>B</sub> <b>LINK_FAIL</b> Link Failure, Link Down in SGMII Mode<br>10 <sub>B</sub> <b>OFFLINE</b> Offline, not used in SGMII Mode<br>11 <sub>B</sub> <b>ANEG_ERROR</b> Auto-negotiation error, not used in SGMII Mode |
| PS    | 2:1  | rwh  | <b>Pause Capability</b><br>Pause Status after auto-negotiation Priority Resolution at link partner, set by HW when OVRABL is DISABLED and ANEG is enabled by HW or SW<br>00 <sub>B</sub> <b>NO</b> No Pause<br>01 <sub>B</sub> <b>RECEIVE</b> Receive PAUSE<br>10 <sub>B</sub> <b>TRANSMIT</b> Transmit PAUSE<br>11 <sub>B</sub> <b>BOTH</b> Receive and Transmit PAUSE   |
| DPX   | 0    | rwh  | <b>Duplex Status</b><br>Duplex Status after auto-negotiation Priority Resolution, set by HW when OVRABL is DISABLED and ANEG is enabled by HW or SW<br>0 <sub>B</sub> <b>HD</b> Half Duplex Mode<br>1 <sub>B</sub> <b>FD</b> Full Duplex Mode   |

**SGMII Interrupt Status**

This register carries information about the source of interrupt from the macro.

|                               |                         |                         |
|-------------------------------|-------------------------|-------------------------|
| <b>SGMII_TBI_ISTAT</b>        | <b>Offset</b>           | <b>Reset Value</b>      |
| <b>SGMII Interrupt Status</b> | <b>D30B<sub>H</sub></b> | <b>0000<sub>H</sub></b> |

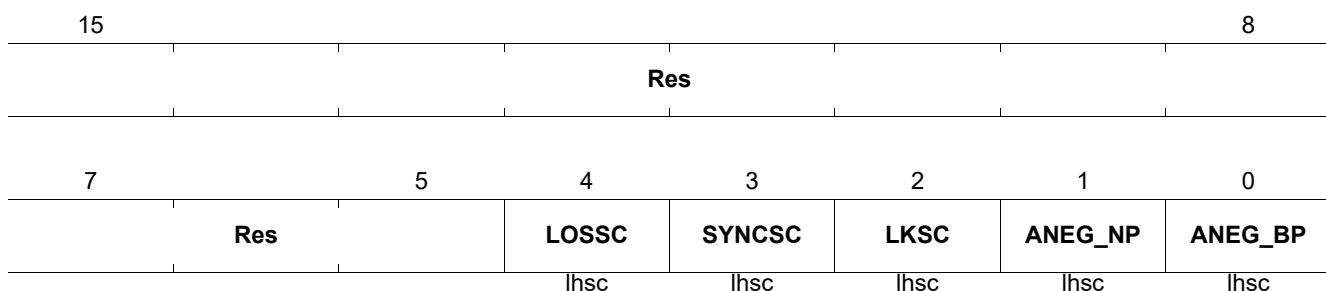

| Field   | Bits | Type | Description  |
|---------|------|------|--|
| LOSSC   | 4    | lhsc | <b>Los Status Change</b><br>The current status of the los signal has changed. Interrupt cleared by writing a 1.  |
| SYNCSC  | 3    | lhsc | <b>Sync Status Change</b><br>The current status of the Synch state machine has changed. Interrupt cleared by writing a 1.  |
| LKSC    | 2    | lhsc | <b>Link Status Change</b><br>The current status of the link has changed either from OK to not OK or vice versa. Interrupt cleared by writing a 1.  |
| ANEG_NP | 1    | lhsc | <b>Auto-Negotiation Interrupt Next Page</b><br>Interrupt generated from auto-negotiation when in COMPLETE_ACKNOWLEDGE state and a next page has been transferred. Firmware must write a fresh value to SGMII_TBI_TXANEGx with NP bit set before timer expires, when another next page operation is required i.e., for the ANEG FSM to move from COMPLETE_ACKNOWLEDGE to NEXT_PAGE_WAIT. Else the FSM moves to IDLE_DETECT state. Interrupt cleared by writing a '1'. |
| ANEG_BP | 0    | lhsc | <b>Auto-Negotiation Interrupt Base Page</b><br>Interrupt generated from auto-negotiation FSM when in COMPLETE_ACKNOWLEDGE state and the base page has been transferred; Firmware must write a fresh value to SGMII_TBI_TXANEGx with NP set before the timer expires, when next page operation is required i.e., for the ANEG FSM to move from COMPLETE_ACKNOWLEDGE to NEXT_PAGE_WAIT. Else the FSM moves to IDLE_DETECT state. Interrupt cleared by writing a '1'.   |

**SGMII Interrupt Mask**

This register carries mask bits for the interrupts described in SGMI\_TBI\_ISTAT.

| SGMII_TBI_IMASK      | Offset            | Reset Value       |
|----------------------|-------------------|-------------------|
| SGMII Interrupt Mask | D30C <sub>H</sub> | 001F <sub>H</sub> |
| 15                   |                   | 8                 |
| Res                  |                   |                   |
| 7                    | 5                 | 4                 |
|                      |                   | 3                 |
|                      |                   | 2                 |
|                      |                   | 1                 |
|                      |                   | 0                 |
|                      | Res               | MLOSSC            |
|                      |                   | MSYNCSC           |
|                      |                   | MLKSC             |
|                      |                   | MANEG_NP          |
|                      |                   | MANEG_BP          |
|                      |                   | rw                |
|                      |                   | rw                |
|                      |                   | rw                |
|                      |                   | rw                |
|                      |                   | rw                |

| Field    | Bits | Type | Description   |
|----------|------|------|---|
| MLOSSC   | 4    | rw   | <b>LOS Status Change</b><br>0 <sub>B</sub> <b>UMASK</b> Unmask LOSSC Interrupt<br>1 <sub>B</sub> <b>MASK</b> Mask LOSSC Interrupt                                     |
| MSYNCSC  | 3    | rw   | <b>Sync Status Change</b><br>0 <sub>B</sub> <b>UMASK</b> Unmask SYNCSC Interrupt<br>1 <sub>B</sub> <b>MASK</b> Mask SYNCSC Interrupt                                  |
| MLKSC    | 2    | rw   | <b>Link Status Change</b><br>0 <sub>B</sub> <b>UMASK</b> Unmask LKSC Interrupt<br>1 <sub>B</sub> <b>MASK</b> Mask LKSC Interrupt                                      |
| MANEG_NP | 1    | rw   | <b>Mask Auto-Negotiation Next Page</b><br>0 <sub>B</sub> <b>UMASK</b> Unmask auto-negotiation interrupt<br>1 <sub>B</sub> <b>MASK</b> Mask auto-negotiation interrupt |
| MANEG_BP | 0    | rw   | <b>Mask Auto-Negotiation Base Page</b><br>0 <sub>B</sub> <b>UMASK</b> Unmask auto-negotiation interrupt<br>1 <sub>B</sub> <b>MASK</b> Mask auto-negotiation interrupt |



**SGMII Transmitter State**

This register indicates the status of the transmit FSM.

| SGMII_TBI_TX_FSM_STAT   | Offset            | Reset Value       |
|-------------------------|-------------------|-------------------|
| SGMII Transmitter State | D30D <sub>H</sub> | 0000 <sub>H</sub> |
| 15                      | Res               | 8                 |
| 7                       | Res               | 0                 |
|                         | TX_FSM_STATUS     |                   |
|                         | rh                |                   |

| Field         | Bits | Type | Description   |
|---------------|------|------|---|
| TX_FSM_STATUS | 4:0  | rh   | <b>State of Transmit FSM</b><br>00000 <sub>B</sub> <b>RESET_TX</b> Reset txstate<br>00001 <sub>B</sub> <b>TX_TEST_TRANSMIT</b> Check xmit state<br>00010 <sub>B</sub> <b>CONFIGURATION_ST</b> Send config part<br>00011 <sub>B</sub> <b>IDLE_TX</b> Send idle<br>00100 <sub>B</sub> <b>XMIT_DATA</b> Send indication for tx data<br>00101 <sub>B</sub> <b>TX_START_OF_PACKET</b> Send sfd<br>00110 <sub>B</sub> <b>TX_DATA</b> Send data<br>00111 <sub>B</sub> <b>TX_END_OF_PACKET_NOEXT</b> Send epd<br>01000 <sub>B</sub> <b>END_OF_PACKET_EXT</b> Send end of packet at txeven is zero and err is zero<br>01001 <sub>B</sub> <b>EPD2_NOEXT</b> Align to txeven is zero<br>01010 <sub>B</sub> <b>EPD3</b> Send R when txeven is one<br>01011 <sub>B</sub> <b>EXTEND_BY_1</b> Send r for carrier ext<br>01100 <sub>B</sub> <b>CARRIER_EXTEND</b> Err is one then send sfd or send start of err<br>01101 <sub>B</sub> <b>ALIGN_ERR_START</b> Send error at txeven<br>01110 <sub>B</sub> <b>START_ERROR</b> Send start of error at one<br>01111 <sub>B</sub> <b>TX_DATA_ERROR</b> Send error data<br>10000 <sub>B</sub> <b>TX_FALSE_CARRIER</b> Send false carrier |

**SGMII Receiver State**

This register indicates the status of the receive FSM.

| SGMII_TBI_RX_FSM_STAT | Offset            | Reset Value       |
|-----------------------|-------------------|-------------------|
| SGMII Receiver State  | D30E <sub>H</sub> | 0000 <sub>H</sub> |
| 15                    |                   | 8                 |
| Res                   |                   |                   |
| 7                     | 5                 | 4                 |
| Res                   | RX_FSM_STATUS     |                   |
|                       |                   | rh                |

| Field         | Bits | Type | Description  |
|---------------|------|------|--|
| RX_FSM_STATUS | 4:0  | rh   | <b>State of Receive FSM</b><br>00000 <sub>B</sub> <b>RESET</b> Reset state<br>00001 <sub>B</sub> <b>LINK_FAILED</b> Link failed<br>00010 <sub>B</sub> <b>WAIT_FOR_K</b> Wait for comma state<br>00011 <sub>B</sub> <b>RX_K</b> Received comma<br>00100 <sub>B</sub> <b>RX_CB</b> Received config bit<br>00101 <sub>B</sub> <b>RX_CC</b> Received config1 bit<br>00110 <sub>B</sub> <b>RX_CD</b> Received config2 bit<br>00111 <sub>B</sub> <b>RX_INVALID</b> Received data is invalid<br>01000 <sub>B</sub> <b>IDLE_D</b> Idle state<br>01001 <sub>B</sub> <b>FALSE_CARRIER</b> False carrier detection<br>01010 <sub>B</sub> <b>START_OF_PACKET</b> Start of packet detected<br>01011 <sub>B</sub> <b>EARLY_END</b> Early end of packet detected<br>01100 <sub>B</sub> <b>TRI_RRI</b> Packet termination received correctly<br>01101 <sub>B</sub> <b>TRR_EXTEND</b> Packet termination received correctly with carrier extend&check epd<br>01110 <sub>B</sub> <b>TRR_EXTEND_A</b> Packet termination received correctly with carrier extend<br>01111 <sub>B</sub> <b>PACKET_BURST_RRS</b> Receiving packet burst<br>10000 <sub>B</sub> <b>EXTEND_ERR</b> Carrier extend err<br>10001 <sub>B</sub> <b>RX_DATA_ERROR</b> Receiving wrong data<br>10010 <sub>B</sub> <b>RX_DATA</b> Receiving data |

## 4.2.2 SGMII\_PCS: SGMII PCS Register File

This section defines all the registers required to operate the SGMII\_PCS module.

### SGMII PCS Configuration

This register contains configuration bits for the PCS.

| SGMII_PCS_CFG           | Offset            | Reset Value       |
|-------------------------|-------------------|-------------------|
| SGMII PCS Configuration | D400 <sub>H</sub> | 0000 <sub>H</sub> |
| 15                      |                   | 8                 |
| Res                     |                   |                   |
| 7                       | 4                 | 3                 |
|                         | 2                 | 1                 |
|                         | 0                 |                   |
|                         | Res               | RTE_EN            |
|                         |                   | INITTX            |
|                         |                   | INITRX            |
|                         |                   | LPB               |
|                         |                   | rw                |
|                         |                   | rw                |
|                         |                   | rw                |
|                         |                   | rw                |

| Field  | Bits | Type | Description  |
|--------|------|------|--|
| RTE_EN | 3    | rw   | <b>RTE Enable</b><br>Used to enable/disable real time Ethernet support.<br>0 <sub>B</sub> <b>DISABLE</b> Disable RTE<br>1 <sub>B</sub> <b>ENABLE</b> Enable RTE  |
| INITTX | 2    | rw   | <b>INIT SGMII TX Path</b><br>Used to reset all transmit operations.<br>0 <sub>B</sub> <b>NORMAL</b> Normal Operation TX<br>1 <sub>B</sub> <b>INIT</b> Reset TX Path  |
| INITRX | 1    | rw   | <b>INIT SGMII RX Path</b><br>Used to reset all receive operations.<br>0 <sub>B</sub> <b>NORMAL</b> Normal Operation TX<br>1 <sub>B</sub> <b>INIT</b> Reset RX Path   |
| LPB    | 0    | rw   | <b>Loop Back RX to TX Path</b><br>Used to loop data from receive buffer to transmit buffer (PCS SGMII loop).<br>0 <sub>B</sub> <b>NORMAL</b> Normal Operation TX<br>1 <sub>B</sub> <b>LOOP</b> Loop back RX to TX Path |

**SGMII PCS Receive Buffer Control**

Used to control the RX buffer operation.

| SGMII_PCS_RXB_CTL                   | Offset                  | Reset Value              |
|-------------------------------------|-------------------------|--------------------------|
| <b>SGMII Receive Buffer Control</b> | <b>D401<sub>H</sub></b> | <b>0001<sub>H</sub></b>  |
| 15                                  |                         | 8                        |
| Res                                 |                         |                          |
| 7                                   | 2                       | 1      0                 |
| Res                                 |                         | INIT_RX_RXB    ENAB_RXB  |
|                                     |                         | rw                    rw |

| Field       | Bits | Type | Description   |
|-------------|------|------|---|
| INIT_RX_RXB | 1    | rw   | <b>Initialize RX Buffer</b><br>Used to reset the RX buffer and associated pointers.<br>0 <sub>B</sub> <b>NORMAL</b> RX Buffer and pointers are normally operating<br>1 <sub>B</sub> <b>ACTIVE</b> RX Buffer and pointers are initialized  |
| ENAB_RXB    | 0    | rw   | <b>Enable RX Buffer</b><br>When this control bit is disabled, the RX Buffer is disabled.<br>The current transfer is NOT affected.<br>This bit is used for the clock-gating.<br>0 <sub>B</sub> <b>DISABLE</b> RX Buffer is disabled<br>1 <sub>B</sub> <b>ENABLE</b> RX Buffer is enabled |

**SGMII PCS Receive Buffer Configuration**

Used to configure the RX buffer operation.

| SGMII_PCS_RXB_CFG                         | Offset                  | Reset Value             |
|---|-------------------------|-------------------------|
| <b>SGMII Receive Buffer Configuration</b> | <b>D402<sub>H</sub></b> | <b>0040<sub>H</sub></b> |
| 15  |                         | 8                       |
| <b>Res</b>                                |                         |                         |
| 7   | 4                       | 3                       |
| 0   |                         |                         |
| <b>DLY_RP_RXB</b>                         |                         | <b>DLY_WP_RXB</b>       |
| rw  |                         | rw                      |

| Field      | Bits | Type | Description   |
|------------|------|------|---|
| DLY_RP_RXB | 7:4  | rw   | <b>Synch Delay</b><br>This register is used to configure the value of write pointer at which the Read pointer is released from its reset value of 0. Actual time of first increment is set by internal synch delays.  |
| DLY_WP_RXB | 3:0  | rw   | <b>Initial Delay</b><br>This register is used to configure the initial delay of the write pointer in the RXB.<br>This delay must be larger than zero to support negative frequency offsets.<br>This delay must be smaller than max to support positive frequency offsets. |

**SGMII PCS Receive Buffer Status**

Indicates the status of the RX buffer.

| SGMII_PCS_RXB_STAT              | Offset            | Reset Value       |
|---------------------------------|-------------------|-------------------|
| SGMII PCS Receive Buffer Status | D403 <sub>H</sub> | 0000 <sub>H</sub> |
| 15                              |                   | 8                 |
| Res                             |                   |                   |
| 7                               | 2                 | 1 0               |
| Res                             |                   | UNFL_RXB OVFL_RXB |
|                                 |                   | lhsc lhsc         |

| Field    | Bits | Type | Description  |
|----------|------|------|--|
| UNFL_RXB | 1    | lhsc | <b>Underflow Indicator</b><br>0 <sub>B</sub> <b>NONE</b> Underflow never detected<br>1 <sub>B</sub> <b>ONCE</b> Underflow occurred at least once |
| OVFL_RXB | 0    | lhsc | <b>Overflow Indicator</b><br>0 <sub>B</sub> <b>NONE</b> Overflow never detected<br>1 <sub>B</sub> <b>ONCE</b> Overflow occurred at least once    |

**SGMII PCS Transmit Buffer Control**

Used to control the TX buffer operation

| SGMII_PCS_TXB_CTL                 | Offset            | Reset Value          |
|-----------------------------------|-------------------|----------------------|
| SGMII PCS Transmit Buffer Control | D404 <sub>H</sub> | 0001 <sub>H</sub>    |
| 15                                |                   | 8                    |
| Res                               |                   |                      |
| 7                                 | 2                 | 1 0                  |
|                                   | Res               | INIT_TX_TXB ENAB_TXB |
|                                   |                   | rw rw                |

| Field       | Bits | Type | Description   |
|-------------|------|------|---|
| INIT_TX_TXB | 1    | rw   | <p><b>Initialize TX Buffer</b></p> <p>Used to reset the TX buffer and associated pointers.</p> <p>0<sub>B</sub> <b>NORMAL</b> TXB is normally operating</p> <p>1<sub>B</sub> <b>ACTIVE</b> TXB is initialized</p>   |
| ENAB_TXB    | 0    | rw   | <p><b>Enable TX Buffer</b></p> <p>When this control bit is disabled the TX Buffer is disabled. The current transfer is NOT affected. This bit is used for the clock-gating.</p> <p>0<sub>B</sub> <b>DISABLE</b> TX Buffer is disabled</p> <p>1<sub>B</sub> <b>ENABLE</b> TX Buffer is enabled</p> |

**SGMII PCS Transmit Buffer Configuration**

Used to configure the TX buffer operation.

| SGMII_PCS_TXB_CFG                       | Offset            | Reset Value       |
|---|-------------------|-------------------|
| SGMII PCS Transmit Buffer Configuration | D405 <sub>H</sub> | 0040 <sub>H</sub> |
| 15                                      |                   | 8                 |
| Res                                     |                   |                   |
| 7                                       | 4                 | 3                 |
| DLY_RP_TXB                              |                   | DLY_WP_TX         |
| rw                                      |                   | rw                |

| Field      | Bits | Type | Description   |
|------------|------|------|---|
| DLY_RP_TXB | 7:4  | rw   | <b>Synch Delay</b><br>This register is used to configure the value of write pointer at which the Read pointer is released from its reset value of 0. Actual time of first increment is set by internal synch delays   |
| DLY_WP_TX  | 3:0  | rw   | <b>Initial Delay</b><br>This register is used to configure the initial delay of the WRITE POINTER in the TXB.<br>This delay must be larger than zero to support negative frequency offsets.<br>This delay must be smaller than max to support positive frequency offsets. |



**SGMII PCS Transmit Buffer Status**

Indicates the status of the TX buffer.

| SGMII_PCS_TXB_STAT               | Offset            | Reset Value       |
|----------------------------------|-------------------|-------------------|
| SGMII PCS Transmit Buffer Status | D406 <sub>H</sub> | 0000 <sub>H</sub> |
| 15                               |                   | 8                 |
| Res                              |                   |                   |
| 7                                | 2                 | 1 0               |
| Res                              |                   | UNFL_TX           |
|                                  |                   | OVFL_TX           |
|                                  |                   | lhsc lhsc         |

| Field   | Bits | Type | Description  |
|---------|------|------|--|
| UNFL_TX | 1    | lhsc | <b>Underflow Indicator</b><br>0 <sub>B</sub> <b>NONE</b> Underflow never detected<br>1 <sub>B</sub> <b>ONCE</b> Underflow occurred at least once |
| OVFL_TX | 0    | lhsc | <b>Overflow Indicator</b><br>0 <sub>B</sub> <b>NONE</b> Overflow never detected<br>1 <sub>B</sub> <b>ONCE</b> Overflow occurred at least once    |

### 4.2.3 SGMII\_PHY: SGMII\_PHY Registers

This section defines all the registers required to operate the SGMII\_PHY module.

#### SGMII PHY Reset

Used to configure SGMII PHY Reset.

| SGMII_PHY_RESETN | Offset            | Reset Value       |
|------------------|-------------------|-------------------|
| SGMII PHY Reset  | D000 <sub>H</sub> | 0001 <sub>H</sub> |
| 15               |                   | 8                 |
| Res              |                   |                   |
| 7                |                   | 0                 |
| Res              |                   | RESET_N           |
|                  |                   | rwh               |

| Field   | Bits | Type | Description  |
|---------|------|------|--|
| RESET_N | 0    | rwh  | <b>RESET_N</b><br>Asynchronous active low reset.<br>0 <sub>B</sub> <b>RESET</b> Reset is triggered.<br>1 <sub>B</sub> <b>NOT_RESET</b> Reset is not triggered. |

**SGMII PHY MPLL CFG1**

Used to configure SGMII PHY MPLL.

| SGMII_PHY_MPLL_CFG1 | Offset            | Reset Value       |
|---------------------|-------------------|-------------------|
| SGMII PHY MPLL CFG1 | D001 <sub>H</sub> | 0000 <sub>H</sub> |
| 15                  | 11                | 10                |
| 7                   | 1                 | 0                 |
| Res                 | REF_USE_PA<br>D   | Res               |
| REF_CLKDIV<br>2     | MPLL_MULTIPLIER   | MPLL_EN           |
| rwh                 | rwh               | rwh               |

| Field               | Bits | Type | Description  |
|---------------------|------|------|--|
| REF_USE_PA<br>D     | 10   | rwh  | <b>MPLL Input Clock Mode</b><br>0 <sub>B</sub> <b>USE_ALT</b> On chip ALT clock is used as MPLL input clock.<br>1 <sub>B</sub> <b>USE_EXT_PAD</b> External reference pad clock is used as MPLL input clock.                    |
| REF_CLKDIV<br>2     | 8    | rwh  | <b>Input Clock Frequency Division Enable</b><br>0 <sub>B</sub> <b>DISABLE</b> Input reference clock frequency divide by 2 is disabled.<br>1 <sub>B</sub> <b>ENABLE</b> Input reference clock frequency divide by 2 is enabled. |
| MPLL_MULTI<br>PLIER | 7:1  | rwh  | <b>MPLL Frequency Multiplier</b><br>MPLL Frequency Multiplier Control  |
| MPLL_EN             | 0    | rwh  | <b>MPLL Enable</b><br>0 <sub>B</sub> <b>DISABLE</b> MPLL is disabled.<br>1 <sub>B</sub> <b>ENABLE</b> MPLL is enabled.   |

**SGMII PHY MPLL CFG2**

Used to configure SGMII PHY MPLL.

| SGMII_PHY_MPLL_CFG2 | Offset            | Reset Value       |
|---------------------|-------------------|-------------------|
| SGMII PHY MPLL CFG2 | D002 <sub>H</sub> | 0000 <sub>H</sub> |
| 15                  | 9                 | 8                 |
| Res                 |                   | SSC_REF_CLK_SEL   |
|                     |                   | rwh               |
| 7                   |                   | 0                 |
| SSC_REF_CLK_SEL     |                   |                   |
|                     | rwh               |                   |

| Field           | Bits | Type | Description  |
|-----------------|------|------|--|
| SSC_REF_CLK_SEL | 8:0  | rwh  | <b>Spread Spectrum Reference Clock Config</b><br>Spread Spectrum Reference Clock shifting for non-integer input reference frequencies to MPLL. |

**SGMII PHY RX0 CFG1**

Used to configure SGMII PHY Receiver.

| SGMII_PHY_RX0_CFG1 | Offset            | Reset Value       |          |   |            |             |              |
|--------------------|-------------------|-------------------|----------|---|------------|-------------|--------------|
| SGMII PHY RX0 CFG1 | D003 <sub>H</sub> | 0000 <sub>H</sub> |          |   |            |             |              |
| 15                 |                   | 8                 |          |   |            |             |              |
| Res                |                   |                   |          |   |            |             |              |
| 7                  | 6                 | 5                 | 4        | 3 | 2          | 1           | 0            |
| Res                |                   | RX0_RESET         | RX0_RATE |   | RX0_PLL_EN | RX0_DATA_EN | RX0_ALIGN_EN |
|                    |                   | rwh               | rwh      |   | rwh        | rwh         | rwh          |

| Field        | Bits | Type | Description   |
|--------------|------|------|---|
| RX0_RESET    | 5    | rwh  | <b>Active High Receiver Reset</b><br>0 <sub>B</sub> <b>NOT_RESET</b> Receiver is not in reset state.<br>1 <sub>B</sub> <b>RESET</b> Receiver is in reset state.                                       |
| RX0_RATE     | 4:3  | rwh  | <b>RX Data Rate</b><br>00 <sub>B</sub> <b>DIV1</b> MPLL_Baud_clk<br>01 <sub>B</sub> <b>DIV2</b> MPLL_Baud_clk/2<br>10 <sub>B</sub> <b>DIV4</b> MPLL_Baud_clk/4<br>11 <sub>B</sub> <b>RES</b> Reserved |
| RX0_PLL_EN   | 2    | rwh  | <b>RX PLL Enable</b><br>0 <sub>B</sub> <b>DISABLE</b> RX PLL is disabled.<br>1 <sub>B</sub> <b>ENABLE</b> RX PLL is enabled.  |
| RX0_DATA_EN  | 1    | rwh  | <b>RX Data Enable</b><br>0 <sub>B</sub> <b>DISABLE</b> RX Data Enable is disabled.<br>1 <sub>B</sub> <b>ENABLE</b> RX Data Enable is enabled.   |
| RX0_ALIGN_EN | 0    | rwh  | <b>RX Align Enable</b><br>0 <sub>B</sub> <b>DISABLE</b> RX Align Enable is disabled.<br>1 <sub>B</sub> <b>ENABLE</b> RX Align Enable is enabled.  |

**SGMII PHY RX0 CFG2**

Used to configure SGMII PHY Receiver.

| SGMII_PHY_RX0_CFG2 |    | Offset            |            | Reset Value       |        |
|--------------------|----|-------------------|------------|-------------------|--------|
| SGMII PHY RX0 CFG2 |    | D004 <sub>H</sub> |            | 0532 <sub>H</sub> |        |
| 15                 | 13 | 12                |            |                   | 8      |
| Res                |    | RX0_LOS_FILT_CNT  |            |                   |        |
| rw                 |    |                   |            |                   |        |
| 7                  | 6  | 5                 | 4          | 3                 | 2      |
| RX0_LOS_FILT_CNT   |    | RX0_TERM_EN       | RX0_LOS_EN | RX0_INVERT        | RX0_EQ |
| rw                 |    | rw                | rw         | rw                | rw     |

| Field            | Bits | Type | Description  |
|------------------|------|------|--|
| RX0_LOS_FILT_CNT | 12:6 | rw   | <b>Loss of Signal Filter Count</b><br>It configures the number of cycles that raw LOS must remain high for rx0_los to assert.  |
| RX0_TERM_EN      | 5    | rw   | <b>RX Receiver Termination</b><br>0 <sub>B</sub> <b>DISABLE</b> RX Receiver Termination removed.<br>1 <sub>B</sub> <b>ENABLE</b> RX Receiver Termination is present.                         |
| RX0_LOS_EN       | 4    | rw   | <b>LOS of Signal Detector Enable</b><br>0 <sub>B</sub> <b>DISABLE</b> LOS of Signal Detector is disabled.<br>1 <sub>B</sub> <b>ENABLE</b> LOS of Signal Detector is enabled.                 |
| RX0_INVERT       | 3    | rw   | <b>RX Data Invert Control</b><br>0 <sub>B</sub> <b>DISABLE</b> Incoming data on rx0_data[19:0] is NOT inverted.<br>1 <sub>B</sub> <b>ENABLE</b> Incoming data on rx0_data[19:0] is inverted. |
| RX0_EQ           | 2:0  | rw   | <b>Receiver Equalization Setting</b><br>"010 <sub>B</sub> " is recommended setting. May vary from system to system.  |

**SGMII PHY TX0 CFG1**

Used to configure SGMII PHY Transmitter.

| SGMII_PHY_TX0_CFG1 | Offset            | Reset Value       |
|--------------------|-------------------|-------------------|
| SGMII PHY TX0 CFG1 | D005 <sub>H</sub> | 0000 <sub>H</sub> |
| 15                 |                   | 8                 |
| Res                |                   |                   |
| 7                  | 6                 | 5                 |
| 4                  | 3                 | 2                 |
| 1                  | 0                 |                   |
| Res                | TX0_RESET         | TX0_RATE          |
|                    | TX0_EN            | TX0_DATA_EN       |
|                    |                   | TX0_CM_EN         |
|                    | rwh               | rwh               |
|                    |                   | rwh               |
|                    |                   | rwh               |
|                    |                   | rwh               |

| Field       | Bits | Type | Description   |
|-------------|------|------|---|
| TX0_RESET   | 5    | rwh  | <b>Active High Transmitter Reset</b><br>0 <sub>B</sub> <b>NOT_RESET</b> NO Reset State<br>1 <sub>B</sub> <b>RESET</b> Reset State   |
| TX0_RATE    | 4:3  | rwh  | <b>TX Data Rate</b><br>00 <sub>B</sub> <b>DIV1</b> MPLL_Baud_clk<br>01 <sub>B</sub> <b>DIV2</b> MPLL_Baud_clk/2<br>10 <sub>B</sub> <b>DIV4</b> MPLL_Baud_clk/4<br>11 <sub>B</sub> <b>RES</b> Reserved |
| TX0_EN      | 2    | rwh  | <b>TX Enable</b><br>0 <sub>B</sub> <b>DISABLE</b> TX is not enabled<br>1 <sub>B</sub> <b>ENABLE</b> TX is enabled   |
| TX0_DATA_EN | 1    | rwh  | <b>TX Data Enable</b><br>0 <sub>B</sub> <b>DISABLE</b> TX data is disabled.<br>1 <sub>B</sub> <b>ENABLE</b> TX data is enabled.   |
| TX0_CM_EN   | 0    | rwh  | <b>TX Common Mode Voltage Enable</b><br>0 <sub>B</sub> <b>DISABLE</b> TX Common Mode Voltage is disabled<br>1 <sub>B</sub> <b>ENABLE</b> TX Common Mode Voltage is enabled                            |

**SGMII PHY TX0 CFG2**

Used to configure SGMII PHY Transmitter.

| SGMII_PHY_TX0_CFG2 |               | Offset            | Reset Value       |
|--------------------|---------------|-------------------|-------------------|
| SGMII PHY TX0 CFG2 |               | D006 <sub>H</sub> | 007F <sub>H</sub> |
| 15                 | 12            | 11                | 8                 |
| Res                |               | TX0_TERM_OFFSET   |                   |
|                    |               | rw                |                   |
| 7                  | 6             |                   |                   |
| TX0_TERM_OFFSET    | TX0_AMPLITUDE |                   |                   |
| rw                 | rw            |                   |                   |

| Field           | Bits | Type | Description  |
|-----------------|------|------|--|
| TX0_TERM_OFFSET | 11:7 | rw   | <b>TX Termination Offset</b><br>Transmitter Termination Offset |
| TX0_AMPLITUDE   | 6:0  | rw   | <b>TX Amplitude Control</b><br>Transmitter Amplitude Control   |



**SGMII PHY TX0 CFG3**

Used to configure SGMII PHY Transmitter.

**SGMII\_PHY\_TX0\_CFG3  
SGMII PHY TX0 CFG3**
**Offset  
D007<sub>H</sub>**
**Reset Value  
0800<sub>H</sub>**

|                              |    |                           |                        |                         |                   |
|------------------------------|----|---------------------------|------------------------|-------------------------|-------------------|
| 15                           | 13 | 12                        | 11                     | 9                       | 8                 |
| <b>Res</b>                   |    | <b>TX0_VBOOST<br/>_EN</b> |                        | <b>TX0_VBOOST_LEVEL</b> | <b>TX0_INVERT</b> |
|                              |    | rw                        |                        | rw                      | rw                |
| 7                            | 6  |                           |                        |                         | 0                 |
| <b>TX0_DETECT<br/>_RX_R*</b> |    |                           | <b>TX0_PREEMPHASIS</b> |                         |                   |
| rw                           |    |                           | rw                     |                         |                   |

| Field             | Bits | Type | Description   |
|-------------------|------|------|---|
| TX0_VBOOST_EN     | 12   | rw   | <b>TX Vboost Enable</b><br>0 <sub>B</sub> <b>DISABLE</b> TX Vboost is disabled.<br>1 <sub>B</sub> <b>ENABLE</b> TX Vboost is enabled.   |
| TX0_VBOOST_LEVEL  | 11:9 | rw   | <b>TX Vboost Level Control</b><br>011 <sub>B</sub> <b>Level3</b> Launch amplitude of 0.844 V<br>100 <sub>B</sub> <b>Level4</b> Launch amplitude of 1.008 V<br>101 <sub>B</sub> <b>Level5</b> Launch amplitude of 1.156 V                                  |
| TX0_INVERT        | 8    | rw   | <b>TX Data Inversion</b><br>0 <sub>B</sub> <b>DISABLE</b> TX Data is NOT inverted.<br>1 <sub>B</sub> <b>ENABLE</b> TX Data is inverted  |
| TX0_DETECT_RX_REQ | 7    | rw   | <b>Remote Receiver Detection Request Enable</b><br>0 <sub>B</sub> <b>DISABLE</b> Remote receiver detection request is disabled<br>1 <sub>B</sub> <b>ENABLE</b> Remote receiver detection request is enabled (must remain high till rx_detect_ack asserts) |
| TX0_PREEMP_HASIS  | 6:0  | rw   | <b>TX Preemphasis Configuration</b><br>Control Transmitter Preemphasis used by transmitter driver   |

**SGMII PHY MISC**

Used to configure SGMII PHY.

| SGMII_PHY_MISC |    | Offset            |           | Reset Value       |                  |             |
|----------------|----|-------------------|-----------|-------------------|------------------|-------------|
| SGMII PHY MISC |    | D008 <sub>H</sub> |           | 0254 <sub>H</sub> |                  |             |
| 15             | 11 | 10                | 8         |                   |                  |             |
| Res            |    |                   | LOS_LEVEL |                   |                  |             |
| rw             |    |                   |           |                   |                  |             |
| 7              | 6  | 5                 | 3         | 2                 | 1 0              |             |
| LOS_LEVEL      |    | LOS_BIAS          |           | LANE_10BIT_SEL    | LANE_LOOPBACK_EN | VREG_BYPASS |
| rw             |    | rw                |           | rw                | rw               | rw          |

| Field            | Bits | Type | Description  |
|------------------|------|------|--|
| LOS_LEVEL        | 10:6 | rw   | <b>LOS Sensitivity Level</b><br>LOSS of Signal Detector Sensitivity Level Control  |
| LOS_BIAS         | 5:3  | rw   | <b>LOS Threshold Level</b><br>LOSS of Signal Detector Threshold Level Control<br>000 <sub>B</sub> <b>RES</b> Reserved<br>001 <sub>B</sub> <b>Level1</b> 120 mV<br>010 <sub>B</sub> <b>Level2</b> 135 mV<br>011 <sub>B</sub> <b>Level3</b> 150 mV<br>100 <sub>B</sub> <b>Level4</b> 45 mV<br>101 <sub>B</sub> <b>Level5</b> 60 mV<br>110 <sub>B</sub> <b>Level6</b> 75 mV<br>111 <sub>B</sub> <b>Level7</b> 90 mV |
| LANE_10BIT_SEL   | 2    | rw   | <b>10 Bit Mode Enable</b><br>0 <sub>B</sub> <b>DISABLE</b> 10 Bit mode is disabled.<br>1 <sub>B</sub> <b>ENABLE</b> 10 Bit mode is enabled.  |
| LANE_LOOPBACK_EN | 1    | rw   | <b>TX to RX Loopback Enable</b><br>0 <sub>B</sub> <b>DISABLE</b> TX-to-RX Loopback is disabled.<br>1 <sub>B</sub> <b>ENABLE</b> TX-to-RX Loopback is enabled.  |
| VREG_BYPASS      | 0    | rw   | <b>Voltage Regulator Bypass Enable</b><br>0 <sub>B</sub> <b>DISABLE</b> 3.3 V Regulator Bypass is disabled.<br>1 <sub>B</sub> <b>ENABLE</b> 3.3 V Regulator Bypass is enabled. 2.5 V external supply is applied to VDDH.   |

**SGMII PHY HWBU CTRL**

Used to configure SGMII PHY.

| SGMII_PHY_HWBU_CTRL | Offset               | Reset Value       |
|---------------------|----------------------|-------------------|
| SGMII PHY HWBU CTRL | D009 <sub>H</sub>    | 0008 <sub>H</sub> |
| 15                  |                      | 8                 |
| Res                 |                      |                   |
| 7                   | 5                    | 4                 |
| Res                 | OVEERIDE_H<br>W_FSM* | HW_FSM_EN         |
|                     |                      | EN_LP_FSM         |
|                     |                      | EN_PD_FSM         |
|                     |                      | EN_HWBU_F<br>SM   |
|                     | rw                   | rw                |

| Field                  | Bits | Type | Description   |
|------------------------|------|------|---|
| OVEERIDE_H<br>W_FSM_EN | 4    | rw   | <b>Hardware Bringup FSM Override Enable</b><br>0 <sub>B</sub> <b>DISABLE</b> Hardware bringup FSM override is disabled. Hardware bringup FSM enable is controlled by top level software.<br>1 <sub>B</sub> <b>ENABLE</b> Hardware bringup FSM override is enabled. Hardware bringup FSM enable is controlled by hardware bringup state machine. |
| HW_FSM_EN              | 3    | rw   | <b>Hardware Bringup FSM Enable</b><br>0 <sub>B</sub> <b>DISABLE</b> Bit 0 (SGMII PHY HWBU CTRL.EN_HWBU_FSM) of this register is used as a FSM disable.<br>1 <sub>B</sub> <b>ENABLE</b> SGMII Macro input pin "en_hwbu_fsm" is used as FSM enable.   |
| EN_LP_FSM              | 2    | rw   | <b>Hardware Bringup Low Power FSM Enable</b><br>0 <sub>B</sub> <b>DISABLE</b> Hardware bringup low power FSM is disabled.<br>1 <sub>B</sub> <b>ENABLE</b> Hardware bringup low power FSM is enabled.  |
| EN_PD_FSM              | 1    | rw   | <b>Hardware Bringup Power Down FSM Enable</b><br>0 <sub>B</sub> <b>DISABLE</b> Hardware bringup power down FSM is disabled.<br>1 <sub>B</sub> <b>ENABLE</b> Hardware bringup power down FSM is enabled.   |
| EN_HWBU_F<br>SM        | 0    | rw   | <b>Hardware Bringup FSM Enable</b><br>0 <sub>B</sub> <b>DISABLE</b> Hardware bringup FSM is disabled.<br>1 <sub>B</sub> <b>ENABLE</b> Hardware bringup FSM is enabled.  |

**SGMII PHY STATUS**

Used to store SGMII PHY status.

| SGMII_PHY_STATUS |  |           |                  |                  |              |               |         | Offset            | Reset Value       |
|------------------|--|-----------|------------------|------------------|--------------|---------------|---------|-------------------|-------------------|
| SGMII PHY STATUS |  |           |                  |                  |              |               |         | D00A <sub>H</sub> | 0000 <sub>H</sub> |
| 15               |  |           |                  | 12               |              | 11            |         | 8                 |                   |
| Res              |  |           |                  | HWBU_FSM_STATE   |              |               |         |                   |                   |
|                  |  |           |                  | rh               |              |               |         |                   |                   |
| 7                |  | 6         | 5                | 4                | 3            | 2             | 1       | 0                 |                   |
| HWBU_FSM_STATE   |  | TX0_STATE | TX0_DETECT_RX_R* | TX0_DETECT_RX_A* | TX0_CM_STATE | RX0_PLL_STATE | RX0_LOS | MPLL_STATE        |                   |
| rh               |  | rh        | rh               | rh               | rh           | rh            | rh      | rh                |                   |

| Field                | Bits | Type | Description   |
|----------------------|------|------|---|
| HWBU_FSM_STATE       | 11:7 | rh   | <b>Hardware Bringup FSM State</b><br>Indicates status of hardware bringup FSM state                               |
| TX0_STATE            | 6    | rh   | <b>TX State</b><br>Indicates Transmitter is ready to Sample transmitter clock and data                            |
| TX0_DETECT_RX_RESULT | 5    | rh   | <b>Detection of Receiver</b><br>Indicates detection of receiver result when asserted along with tx0_detect_rx_ack |
| TX0_DETECT_RX_ACK    | 4    | rh   | <b>Detection of Receiver Acknowledgment</b><br>Indicates detection of receiver acknowledgment.                    |
| TX0_CM_STATE         | 3    | rh   | <b>TX CM Acknowledgment</b><br>Indicates acknowledgment to TX CM enable   |
| RX0_PLL_STATE        | 2    | rh   | <b>RX PLL State</b><br>Indicates acknowledgment to RX0 PLL enable   |
| RX0_LOS              | 1    | rh   | <b>RX Loss of Signal Status</b><br>Indicates RX0 loss of signal   |
| MPLL_STATE           | 0    | rh   | <b>MPLL State</b><br>Indicates acknowledgment to MPLL enable  |

**SGMII PHY D**

Used to configure/store data for read and write transaction.

| SGMII_PHY_D | Offset            | Reset Value       |
|-------------|-------------------|-------------------|
| SGMII PHY D | D100 <sub>H</sub> | 0000 <sub>H</sub> |
| 15          |                   | 8                 |
|             | DATA              |                   |
|             | rwh               |                   |
| 7           |                   | 0                 |
|             | DATA              |                   |
|             | rwh               |                   |

| Field | Bits | Type | Description   |
|-------|------|------|---|
| DATA  | 15:0 | rwh  | <p><b>Data</b></p> <p>When a XAUI control read transaction has completed, the return value may be read from here.</p> <p>When a XAUI control write transaction is to be performed the desired write data must be written here prior to issuing a write via SGMII_PHY_C.</p> |

**SGMII PHY A**

Used to configure address for read and write transaction.

| SGMII_PHY_A    | Offset            | Reset Value       |
|----------------|-------------------|-------------------|
| SGMII PHY A    | D101 <sub>H</sub> | 0000 <sub>H</sub> |
| 15             |                   | 8                 |
| <b>ADDRESS</b> |                   |                   |
| rw             |                   |                   |
| 7              |                   | 0                 |
| <b>ADDRESS</b> |                   |                   |
| rw             |                   |                   |

| Field   | Bits | Type | Description   |
|---------|------|------|---|
| ADDRESS | 15:0 | rw   | <b>Address</b><br>When a XAUI control read or write transaction is to be performed, the desired address must be written here. Values written here are available for reading back. |

**SGMII PHY C**

Used to configure read and write transaction control

| SGMII_PHY_C |    | Offset            |    | Reset Value       |             |
|-------------|----|-------------------|----|-------------------|-------------|
| SGMII PHY C |    | D102 <sub>H</sub> |    | 1000 <sub>H</sub> |             |
| 15          | 13 | 12                | 11 | 9                 | 8           |
| Res         |    | RESET_N1          |    | Res               | ISSUE_WRITE |
|             |    | rw                |    | rwh               |             |
| 7           | 5  | 4                 | 3  | 1                 | 0           |
| Res         |    | ISSUE_READ        |    | Res               | STATUS      |
|             |    | rwh               |    | rh                |             |

| Field       | Bits | Type | Description  |
|-------------|------|------|--|
| RESET_N1    | 12   | rw   | <b>Active Low Reset</b><br>Active low asynchronous reset to PDI2CR statemachine. Write 1b'0 to reset.  |
| ISSUE_WRITE | 8    | rwh  | <b>Start Write Access</b><br>When written to a one, the XAUI address stored in SGMII_PHY_A is written with the data value stored in SGMII_PHY_D.   |
| ISSUE_READ  | 4    | rwh  | <b>Start Read Access</b><br>When written to a one, the XAUI address stored in SGMII_PHY_A is read from the XAUI module, and the result deposited in SGMII_PHY_D. This bit auto clears.   |
| STATUS      | 0    | rh   | <b>Status</b><br>When a register transaction to the XAUI is initiated, this bit auto clears to 0.<br>When the transaction is completed this register is then set to 1.<br>After initiation of a XAUI read or write, firmware must poll for this bit to be a 1.<br>This bit stays at 1 until reset or until a new transaction is initiated. |

**SGMII PHY WATCHDOG CONTROL**

Used to configure watchdog control.

| SGMII_PHY_WATCHDOG_CTRL    | Offset            | Reset Value       |
|----------------------------|-------------------|-------------------|
| SGMII PHY WATCHDOG CONTROL | D111 <sub>H</sub> | 0000 <sub>H</sub> |
| 15                         |                   | 8                 |
| Res                        |                   |                   |
| 7                          | 2                 | 1 0               |
| Res                        |                   | WATCHDOG_ EN      |
|                            |                   | WATCHDOG_ ERR     |
|                            |                   | rw rh             |

| Field         | Bits | Type | Description  |
|---------------|------|------|--|
| WATCHDOG_ EN  | 1    | rw   | <b>Watchdog Enable</b><br>Enable watchdog timer.             |
| WATCHDOG_ ERR | 0    | rh   | <b>Watchdog Error Value</b><br>Watchdog reset state machine. |

**SGMII PHY WATCHDOG TIMER**

Used to configure watchdog timer.

| SGMII_PHY_WATCHDOG_TIMER | Offset            | Reset Value       |
|--------------------------|-------------------|-------------------|
| SGMII PHY WATCHDOG TIMER | D112 <sub>H</sub> | FFFF <sub>H</sub> |
| 15                       |                   | 8                 |
| WATCHDOG_VAL             |                   |                   |
| rw                       |                   |                   |
| 7                        |                   | 0                 |
| WATCHDOG_VAL             |                   |                   |
| rw                       |                   |                   |

| Field         | Bits | Type | Description   |
|---------------|------|------|---|
| WATCHDOG_ VAL | 15:0 | rw   | <b>Watchdog Timer Value</b><br>Watchdog timer value |



#### 4.2.4 SGMII\_MACRO\_REGISTERS: SGMII\_MACRO Registers

This section defines all the registers required to operate the SGMII\_MACRO module.<sup>1)</sup>

##### SGMII Macro Reset Control

Hold bits that control top level resets of the macro.

| SGMII_MACRO_RESETN        | Offset            | Reset Value                       |
|---------------------------|-------------------|-----------------------------------|
| SGMII Macro Reset Control | D200 <sub>H</sub> | 0003 <sub>H</sub>                 |
| 15                        |                   | 8                                 |
| Res                       |                   |                                   |
| 7                         | 2                 | 1 0                               |
|                           | Res               | SGMII_PCS_RESETN SGMII_PHY_RESETN |
|                           |                   | rw rw                             |

| Field            | Bits | Type | Description   |
|------------------|------|------|---|
| SGMII_PCS_RESETN | 1    | rw   | <b>SGMII_PCS_RESETN</b><br>Resets all PCS operations of the SGMII Macro.<br>0 <sub>B</sub> <b>RESET</b> RESET<br>1 <sub>B</sub> <b>NOT_RESET</b> NO_RESET         |
| SGMII_PHY_RESETN | 0    | rw   | <b>SGMII_PHY_RESETN</b><br>Resets all operations related to the SGMII_PHY Macro.<br>0 <sub>B</sub> <b>RESET</b> RESET<br>1 <sub>B</sub> <b>NOT_RESET</b> NO_RESET |

1) Generated by REFIGE v1.4 - Beta Release XIV

**SGMII Macro SGMII CTRL1**

Used to configure SGMII interface mode.

| SGMII_MACRO_SGMII_CTRL1 |        | Offset            |                      | Reset Value       |             |     |
|-------------------------|--------|-------------------|----------------------|-------------------|-------------|-----|
| SGMII Macro SGMII CTRL1 |        | D201 <sub>H</sub> |                      | 020C <sub>H</sub> |             |     |
| 15                      | 11     | 10                | 9                    | 8                 |             |     |
| Res                     |        |                   | LPI_MODE_A<br>ACTIVE | Res               | Q_RVBO      |     |
|                         |        |                   | rw                   |                   |             |     |
| 7                       | 6      | 5                 | 4                    | 3                 | 2           |     |
| Q_RVBI                  | Q_JITE |                   | DISPAR_EN            | RX_RD_INITN       | TX_RD_INITN | Res |
| rw                      | rw     |                   | rw                   | rw                | rw          |     |

| Field                | Bits | Type | Description  |
|----------------------|------|------|--|
| LPI_MODE_A<br>ACTIVE | 10   | rw   | <b>LPI Mode Enable</b><br>0 <sub>B</sub> <b>DISABLE</b> LPI mode is disabled.<br>1 <sub>B</sub> <b>ENABLE</b> LPI mode is enabled.   |
| Q_RVBO               | 8    | rw   | <b>Reverse Bit Order Output</b><br>0 <sub>B</sub> <b>DISABLE</b> Reverse bit order output is disabled.<br>1 <sub>B</sub> <b>ENABLE</b> Reverse bit order output is enabled.  |
| Q_RVBI               | 7    | rw   | <b>Reverse Bit Order Input</b><br>0 <sub>B</sub> <b>DISABLE</b> Reverse bit order input is disabled.<br>1 <sub>B</sub> <b>ENABLE</b> Reverse bit order input is enabled.   |
| Q_JITE               | 6:5  | rw   | <b>TX Jitter Test Pattern</b><br>00 <sub>B</sub> <b>NO</b> Normal Function<br>01 <sub>B</sub> <b>HIGH</b> Transmit high frequency test pattern 36A.1<br>10 <sub>B</sub> <b>LOW</b> Transmit low frequency test pattern 36A.2<br>11 <sub>B</sub> <b>MIXED</b> Transmit mixed frequency test pattern 36A.3 |
| DISPAR_EN            | 4    | rw   | <b>Disparity Enable</b><br>0 <sub>B</sub> <b>DISABLE</b> Disparity is disabled.<br>1 <sub>B</sub> <b>ENABLE</b> Disparity is enabled.  |
| RX_RD_INITN          | 3    | rw   | <b>RX Running Disparity</b><br>0 <sub>B</sub> <b>INIT0</b> RX Running Disparity is initialized to '0'.<br>1 <sub>B</sub> <b>INIT1</b> RX Running Disparity is initialized to '1'.  |
| TX_RD_INITN          | 2    | rw   | <b>TX Running Disparity</b><br>0 <sub>B</sub> <b>INIT0</b> TX Running Disparity is initialized to '0'.<br>1 <sub>B</sub> <b>INIT1</b> TX Running Disparity is initialized to '1'.  |

**SGMII Macro Clock Control**

Controls gating of various SGMII macro clocks.

| SGMII_MACRO_CLK_CTRL      |    | Offset            |    | Reset Value       |                  |
|---------------------------|----|-------------------|----|-------------------|------------------|
| SGMII Macro Clock Control |    | D20F <sub>H</sub> |    | 1111 <sub>H</sub> |                  |
| 15                        | 13 | 12                | 11 | 9                 | 8                |
| Res                       |    | GMII_RXCLK_EN     |    | Res               | GMII_TXCLK_EN    |
|                           |    | rw                |    |                   | rw               |
| 7                         | 5  | 4                 | 3  | 1                 | 0                |
| Res                       |    | XAUI_PHY_RX_CLK*  |    | Res               | XAUI_PHY_TX_CLK* |
|                           |    | rw                |    |                   | rw               |

| Field              | Bits | Type | Description  |
|--------------------|------|------|--|
| GMII_RXCLK_EN      | 12   | rw   | <b>GMII RX Clock Enable</b><br>Enables the GMII RX clock to PCS layer<br>0 <sub>B</sub> <b>DISABLE</b> RX clock is disabled<br>1 <sub>B</sub> <b>ENABLE</b> RX clock is enabled                            |
| GMII_TXCLK_EN      | 8    | rw   | <b>GMII TX Clock Enable</b><br>Enables the GMII Tx clock to PCS layer<br>0 <sub>B</sub> <b>DISABLE</b> TX clock is disabled<br>1 <sub>B</sub> <b>ENABLE</b> TX clock is enabled                            |
| XAUI_PHY_RX_CLK_EN | 4    | rw   | <b>PMD/PMA Core's RX Clock Enable</b><br>Enables the PMD/PMA Core's RX data clock to PCS layer<br>0 <sub>B</sub> <b>DISABLE</b> RX clock is disabled.<br>1 <sub>B</sub> <b>ENABLE</b> RX clock is enabled. |
| XAUI_PHY_TX_CLK_EN | 0    | rw   | <b>PMD/PMA Core's TX Clock Enable</b><br>Enables the PMD/PMA Core's Tx data clock to PCS layer<br>0 <sub>B</sub> <b>DISABLE</b> TX clock is disabled.<br>1 <sub>B</sub> <b>ENABLE</b> TX clock is enabled. |

### 4.3 PHY MDIO Registers

This section defines all the registers required to operate the REGISTERS module.<sup>1)</sup>

**Table 59 Registers Address Space**

| Module    | Base Address    | End Address     | Note |
|-----------|-----------------|-----------------|------|
| REGISTERS | 00 <sub>H</sub> | 60 <sub>H</sub> |      |

**Table 60 Registers Overview**

| Register Short Name   | Register Long Name  | Offset Address  | Reset Value       |
|---|---|-----------------|-------------------|
| <b>PHY MDIO Registers, STD: Standard Management Registers</b>     |   |                 |                   |
| <b>CTRL</b>   | Control   | 00 <sub>H</sub> | 9040 <sub>H</sub> |
| <b>STAT</b>   | Status Registers  | 01 <sub>H</sub> | 7949 <sub>H</sub> |
| <b>PHYID1</b>   | PHY Identifier 1  | 02 <sub>H</sub> | D565 <sub>H</sub> |
| <b>PHYID2</b>   | PHY Identifier 2  | 03 <sub>H</sub> | A409 <sub>H</sub> |
| <b>AN_ADV</b>   | Auto-Negotiation Advertisement                            | 04 <sub>H</sub> | 01E1 <sub>H</sub> |
| <b>AN_LPA</b>   | Auto-Negotiation Link-Partner Ability                     | 05 <sub>H</sub> | 0000 <sub>H</sub> |
| <b>AN_EXP</b>   | Auto-Negotiation Expansion                                | 06 <sub>H</sub> | 0004 <sub>H</sub> |
| <b>AN_NPTX</b>  | Auto-Negotiation Next-Page Transmit Register              | 07 <sub>H</sub> | 2001 <sub>H</sub> |
| <b>AN_NPRX</b>  | Auto-Negotiation Link-Partner Received Next-Page Register | 08 <sub>H</sub> | 2001 <sub>H</sub> |
| <b>GCTRL</b>  | Gigabit Control Register                                  | 09 <sub>H</sub> | 0300 <sub>H</sub> |
| <b>GSTAT</b>  | Gigabit Status Register                                   | 0A <sub>H</sub> | 0000 <sub>H</sub> |
| <b>RES11</b>  | Reserved  | 0B <sub>H</sub> | 0000 <sub>H</sub> |
| <b>RES12</b>  | Reserved  | 0C <sub>H</sub> | 0000 <sub>H</sub> |
| <b>MMDCTRL</b>  | MMD Access Control Register                               | 0D <sub>H</sub> | 0000 <sub>H</sub> |
| <b>MMDDATA</b>  | MMD Access Data Register                                  | 0E <sub>H</sub> | 0000 <sub>H</sub> |
| <b>XSTAT</b>  | Extended Status Register                                  | 0F <sub>H</sub> | 3000 <sub>H</sub> |
| <b>PHY MDIO Registers, PHY: PHY-Specific Management Registers</b> |   |                 |                   |
| <b>PHYPERF</b>  | Physical Layer Performance Status                         | 10 <sub>H</sub> | 80FF <sub>H</sub> |
| <b>PHYSTAT1</b>   | Physical Layer Status 1                                   | 11 <sub>H</sub> | 0000 <sub>H</sub> |
| <b>PHYSTAT2</b>   | Physical Layer Status 2                                   | 12 <sub>H</sub> | 0000 <sub>H</sub> |
| <b>PHYCTL1</b>  | Physical Layer Control 1                                  | 13 <sub>H</sub> | 0003 <sub>H</sub> |
| <b>PHYCTL2</b>  | Physical Layer Control 2                                  | 14 <sub>H</sub> | 8006 <sub>H</sub> |
| <b>ERRCNT</b>   | Error Counter   | 15 <sub>H</sub> | 0000 <sub>H</sub> |
| <b>MIISTAT</b>  | Media-Independent Interface Status                        | 18 <sub>H</sub> | 0000 <sub>H</sub> |
| <b>IMASK</b>  | Interrupt Mask Register                                   | 19 <sub>H</sub> | 0000 <sub>H</sub> |
| <b>ISTAT</b>  | Interrupt Status Register                                 | 1A <sub>H</sub> | 0000 <sub>H</sub> |
| <b>LED</b>  | LED Control Register                                      | 1B <sub>H</sub> | 0F00 <sub>H</sub> |
| <b>TPGCTRL</b>  | Test-Packet Generator Control                             | 1C <sub>H</sub> | 0000 <sub>H</sub> |

1) Generated by REFIGE v1.4 - Beta Release XIV

**Table 60 Registers Overview (cont'd)**

| Register Short Name | Register Long Name         | Offset Address  | Reset Value       |
|---------------------|----------------------------|-----------------|-------------------|
| <b>TPGDATA</b>      | Test-Packet Generator Data | 1D <sub>H</sub> | 00AA <sub>H</sub> |
| <b>FWV</b>          | Firmware Version Register  | 1E <sub>H</sub> | 8304 <sub>H</sub> |
| <b>RES1F</b>        | Reserved                   | 1F <sub>H</sub> | 0000 <sub>H</sub> |

The register is addressed wordwise.

**Table 61 Register Access Types**

| Mode                               | Symbol | Internal Hardware Configuration |          |             |
|------------------------------------|--------|---------------------------------|----------|-------------|
|                                    |        | Type                            | Behavior | Arbitration |
| Status Register, Latch-High        | ROLH   | RWRE                            | AUTO_PDI | CLROR       |
| Status Register, Latch-Low         | ROLL   | WOR                             | AUTO_HW  | CLROR       |
| Status Register, Self-Clearing     | ROSC   | WOR                             | AUTO_PDI | CLROR       |
| Read-Write Register                | RW     | RWR                             | AUTO_PDI | -           |
| Read-Write Register, Self-Clearing | RWSC   | RWR                             | AUTO_PDI | CLROR       |
| Status Register                    | RO     | WOR                             | AUTO_PDI | -           |

### 4.3.1 STD: Standard Management Registers

This section describes the IEEE 802.3 standard management registers.

#### Control

This register controls the main functions of the PHY. Refer to IEEE 802.3 22.2.4.1.

| CTRL       |            | Offset          |             | Reset Value       |             |             |             |
|------------|------------|-----------------|-------------|-------------------|-------------|-------------|-------------|
| Control    |            | 00 <sub>H</sub> |             | 9040 <sub>H</sub> |             |             |             |
| 15         | 14         | 13              | 12          | 11                | 10          | 9           | 8           |
| <b>RST</b> | <b>LB</b>  | <b>SSL</b>      | <b>ANEN</b> | <b>PD</b>         | <b>ISOL</b> | <b>ANRS</b> | <b>DPLX</b> |
| rWSC       | rW         | rW              | rW          | rW                | rW          | rWSC        | rW          |
| 7          | 6          | 5               |             |                   |             |             | 0           |
| <b>COL</b> | <b>SSM</b> |                 |             | <b>RES</b>        |             |             |             |
| rW         | rW         |                 |             | r0                |             |             |             |

| Field | Bits | Type | Description   |
|-------|------|------|---|
| RST   | 15   | RWSC | <b>Reset</b><br>Resets the PHY to its default state. Active links are terminated. This is a self-clearing bit set to zero by the hardware after reset has been done. Refer to IEEE 802.3 22.2.4.1.1.<br>0 <sub>B</sub> <b>NORMAL</b> Normal operational mode<br>1 <sub>B</sub> <b>RESET</b> Resets the device   |
| LB    | 14   | RW   | <b>Loopback</b><br>This mode enables looping back of MII data from the transmit to the receive direction. No data is transmitted to the medium via MDI. The device operates at the selected speed. The collision signal remains de-asserted unless otherwise forced by the collision test. Refer to IEEE 802.8-2008 22.2.4.1.2.<br>0 <sub>B</sub> <b>NORMAL</b> Normal operational mode<br>1 <sub>B</sub> <b>ENABLE</b> Closes the loopback from TX to RX at xMII |
| SSL   | 13   | RW   | <b>Forced Speed Selection LSB</b><br>This bit only takes effect when the auto-negotiation process is disabled, that is, bit CTRL. ANEN is set to zero. This is the LSB (CTRL.SSL) of the forced speed-selection register SS. In conjunction with the MSB (CTRL.SSM), the following encodings are valid:<br>SS=0: 10 Mbps<br>SS=1: 100 Mbps<br>SS=2: 1000 Mbps<br>SS=3: Reserved   |

| Field | Bits | Type | Description   |
|-------|------|------|---|
| ANEN  | 12   | RW   | <b>Auto-Negotiation Enable</b><br>Allows enabling and disabling of the auto-negotiation process capability of the PHY. When enabled, the force bits for duplex mode (CTRL.DPLX) and the speed selection (CTRL.SSM, CTRL.SSL) become inactive. Otherwise, the force bits define the PHY operation. Refer to IEEE 802.3 22.2.4.1.4.<br>0 <sub>B</sub> <b>DISABLE</b> Disable the auto-negotiation protocol<br>1 <sub>B</sub> <b>ENABLE</b> Enable the auto-negotiation protocol               |
| PD    | 11   | RW   | <b>Power Down</b><br>Forces the device into a power-down state where power consumption is the bare minimum required to still maintain the MII management interface communication. When activating the power-down functionality, the PHY terminates active data links. None of the xMII interface work in power-down mode. Refer to IEEE 802.3 22.2.4.1.5.<br>0 <sub>B</sub> <b>NORMAL</b> Normal operational mode<br>1 <sub>B</sub> <b>POWERDOWN</b> Forces the device into power-down mode |
| ISOL  | 10   | RW   | <b>Isolation Mode</b><br>The isolation mode isolates the PHY from the MAC. MAC interface inputs are ignored, whereas MAC interface outputs are set to tristate (high-impedance). Refer to IEEE 802.3 22.2.4.1.6.<br>0 <sub>B</sub> <b>NORMAL</b> Normal operational mode<br>1 <sub>B</sub> <b>ISOLATE</b> Isolates the PHY from the MAC   |
| ANRS  | 9    | RWSC | <b>Restart Auto-Negotiation</b><br>Restarts the auto-negotiation process on the MDI. This bit does not take any effect when auto-negotiation is disabled using (CTRL.ANEN). This bit is self-clearing after the auto-negotiation process is initiated. Refer to IEEE 802.3 22.2.4.1.7.<br>0 <sub>B</sub> <b>NORMAL</b> Stay in current mode<br>1 <sub>B</sub> <b>RESTART</b> Restart auto-negotiation   |
| DPLX  | 8    | RW   | <b>Forced Duplex Mode</b><br>This bit only takes effect when the auto-negotiation process is disabled, that is, bit CTRL.ANEN is set to zero. This bit controls the forced duplex mode. It allows forcing of the PHY into full or half-duplex mode. This bit does not take effect in loop-back mode, that is, when bit CTRL.LB is set to one. Refer to IEEE 802.3 22.2.4.1.8.<br>0 <sub>B</sub> <b>HD</b> Half duplex<br>1 <sub>B</sub> <b>FD</b> Full duplex                               |
| COL   | 7    | RW   | <b>Collision Test</b><br>Allows \$WORKAREA/units/mdio/source testing of the COL signal at the xMII interface. When the collision test is enabled, the state of the TX_EN signal is looped back to the COL signal within a minimum latency time. Refer to IEEE 802.3 22.2.4.1.9.<br>0 <sub>B</sub> <b>DISABLE</b> Normal operational mode<br>1 <sub>B</sub> <b>ENABLE</b> Activates the collision test   |
| SSM   | 6    | RW   | <b>Forced Speed Selection MSB</b><br>Refer to the description of SSL. Refer also to IEEE 802.3-2008 22.2.4.1.3.   |
| RES   | 5:0  | RO   | <b>Reserved</b><br>Write as zero, ignore on read.   |

**Status Registers**

This register contains status and capability information about the device. All bits are read-only. A write access by the MAC does not have any effect. Refer to IEEE 802.3 22.2.4.2.

| STAT             |              | Offset          |             | Reset Value       |              |              |             |
|------------------|--------------|-----------------|-------------|-------------------|--------------|--------------|-------------|
| Status Registers |              | 01 <sub>H</sub> |             | 7949 <sub>H</sub> |              |              |             |
| 15               | 14           | 13              | 12          | 11                | 10           | 9            | 8           |
| <b>CBT4</b>      | <b>CBTXF</b> | <b>CBTXH</b>    | <b>XBTF</b> | <b>XBTH</b>       | <b>CBT2F</b> | <b>CBT2H</b> | <b>EXT</b>  |
| ro               | ro           | ro              | ro          | ro                | ro           | ro           | ro          |
| 7                | 6            | 5               | 4           | 3                 | 2            | 1            | 0           |
| <b>RES</b>       | <b>MFPS</b>  | <b>ANOK</b>     | <b>RF</b>   | <b>ANAB</b>       | <b>LS</b>    | <b>JD</b>    | <b>XCAP</b> |
| ro               | ro           | ro              | rolh        | ro                | roll         | rolh         | ro          |

| Field | Bits | Type | Description  |
|-------|------|------|--|
| CBT4  | 15   | RO   | <b>IEEE 100BASE-T4</b><br>Specifies the 100BASE-T4 ability. Refer to IEEE 802.3 22.2.4.2.1.<br>0 <sub>B</sub> <b>DISABLED</b> PHY does not support this mode<br>1 <sub>B</sub> <b>ENABLED</b> PHY supports this mode                         |
| CBTXF | 14   | RO   | <b>IEEE 100BASE-TX Full-Duplex</b><br>Specifies the 100BASE-TX full-duplex ability. Refer to IEEE 802.3 22.2.4.2.2.<br>0 <sub>B</sub> <b>DISABLED</b> PHY does not support this mode<br>1 <sub>B</sub> <b>ENABLED</b> PHY supports this mode |
| CBTXH | 13   | RO   | <b>IEEE 100BASE-TX Half-Duplex</b><br>Specifies the 100BASE-TX half-duplex ability. Refer to IEEE 802.3 22.2.4.2.3.<br>0 <sub>B</sub> <b>DISABLED</b> PHY does not support this mode<br>1 <sub>B</sub> <b>ENABLED</b> PHY supports this mode |
| XBTF  | 12   | RO   | <b>IEEE 10BASE-T Full-Duplex</b><br>Specifies the 10 BASE-T full-duplex ability. Refer to IEEE 802.3 22.2.4.2.4.<br>0 <sub>B</sub> <b>DISABLED</b> PHY does not support this mode<br>1 <sub>B</sub> <b>ENABLED</b> PHY supports this mode    |
| XBTH  | 11   | RO   | <b>IEEE 10BASE-T Half-Duplex</b><br>Specifies the 10BASE-T half-duplex ability. Refer to IEEE 802.3 22.2.4.2.5.<br>0 <sub>B</sub> <b>DISABLED</b> PHY does not support this mode<br>1 <sub>B</sub> <b>ENABLED</b> PHY supports this mode     |
| CBT2F | 10   | RO   | <b>IEEE 100BASE-T2 Full-Duplex</b><br>Specifies the 100BASE-T2 full-duplex ability. Refer to IEEE 802.3 22.2.4.2.6.<br>0 <sub>B</sub> <b>DISABLED</b> PHY does not support this mode<br>1 <sub>B</sub> <b>ENABLED</b> PHY supports this mode |
| CBT2H | 9    | RO   | <b>IEEE 100BASE-T2 Half-Duplex</b><br>Specifies the 100BASE-T2 half-duplex ability. Refer to IEEE 802.3 22.2.4.2.7.<br>0 <sub>B</sub> <b>DISABLED</b> PHY does not support this mode<br>1 <sub>B</sub> <b>ENABLED</b> PHY supports this mode |



| Field | Bits | Type | Description  |
|-------|------|------|--|
| EXT   | 8    | RO   | <b>Extended Status</b><br>The extended status registers are used to specify 1000 Mbps speed capabilities in the register XSTAT. Refer to IEEE 802.3 22.2.4.2.16.<br>0 <sub>B</sub> <b>DISABLED</b> No extended status information available in register 15<br>1 <sub>B</sub> <b>ENABLED</b> Extended status information available in register 15 |
| RES   | 7    | RO   | <b>Reserved</b><br>Ignore when read.   |
| MFPS  | 6    | RO   | <b>Management Preamble Suppression</b><br>Specifies the MF preamble suppression ability. Refer to IEEE 802.3 22.2.4.2.9.<br>0 <sub>B</sub> <b>DISABLED</b> PHY requires management frames with preamble<br>1 <sub>B</sub> <b>ENABLED</b> PHY accepts management frames without preamble  |
| ANOK  | 5    | RO   | <b>Auto-Negotiation Completed</b><br>Indicates whether the auto-negotiation process is completed or in progress. Refer to IEEE 802.3 22.2.4.2.10.<br>0 <sub>B</sub> <b>RUNNING</b> Auto-negotiation process is in progress<br>1 <sub>B</sub> <b>COMPLETED</b> Auto-negotiation process is completed  |
| RF    | 4    | ROLH | <b>Remote Fault</b><br>Indicates the detection of a remote fault event. Refer to IEEE 802.3 22.2.4.2.11.<br>0 <sub>B</sub> <b>INACTIVE</b> No remote fault condition detected<br>1 <sub>B</sub> <b>ACTIVE</b> Remote fault condition detected  |
| ANAB  | 3    | RO   | <b>Auto-Negotiation Ability</b><br>Specifies the auto-negotiation ability. Refer to IEEE 802.3 22.2.4.2.12.<br>0 <sub>B</sub> <b>DISABLED</b> PHY is not able to perform auto-negotiation<br>1 <sub>B</sub> <b>ENABLED</b> PHY is able to perform auto-negotiation   |
| LS    | 2    | ROLL | <b>Link Status</b><br>Indicates the link status of the PHY to the link partner. Refer to IEEE 802.3 22.2.4.2.13.<br>0 <sub>B</sub> <b>INACTIVE</b> The link is down. No communication with link partner possible.<br>1 <sub>B</sub> <b>ACTIVE</b> The link is up. Data communication with link partner is possible.                              |
| JD    | 1    | ROLH | <b>Jabber Detect</b><br>Indicates that a jabber event has been detected. Refer to IEEE 802.3 22.2.4.2.14.<br>0 <sub>B</sub> <b>NONE</b> No jabber condition detected<br>1 <sub>B</sub> <b>DETECTED</b> Jabber condition detected   |
| XCAP  | 0    | RO   | <b>Extended Capability</b><br>Indicates the availability and support of extended capability registers. Refer to IEEE 802.3 22.2.4.2.15.<br>0 <sub>B</sub> <b>DISABLED</b> Only base registers are supported<br>1 <sub>B</sub> <b>ENABLED</b> Extended capability registers are supported   |

**PHY Identifier 1**

This is the first of two PHY identification registers containing the MSBs of a 32-bit code. This code specifies the Organizationally Unique Identifier (OUI), and the vendor model and revision number.

| PHYID1           | Offset          | Reset Value       |
|------------------|-----------------|-------------------|
| PHY Identifier 1 | 02 <sub>H</sub> | D565 <sub>H</sub> |
| 15               |                 | 8                 |
|                  | OUI             |                   |
|                  | ro              |                   |
| 7                |                 | 0                 |
|                  | OUI             |                   |
|                  | ro              |                   |

| Field | Bits | Type | Description   |
|-------|------|------|---|
| OUI   | 15:0 | RO   | <b>Organizationally Unique Identifier Bits 3:18</b><br>This register holds the bits 3:18 of the OUI code for MaxLinear Inc., which is specified to be OUI=AC-9A-96. Refer to IEEE 802.3 22.2.4.3.1. |

**PHY Identifier 2**

This is the second of 2 PHY identification registers containing the LSBs of a 32-bit code. This code specifies the Organizationally Unique Identifier (OUI), and the vendor model and revision number. Refer to IEEE 802.3 22.2.4.3.1.

| PHYID2           | Offset          | Reset Value       |
|------------------|-----------------|-------------------|
| PHY Identifier 2 | 03 <sub>H</sub> | A409 <sub>H</sub> |
| 15               |                 | 10 9 8            |
|                  | OUI             | LDN               |
|                  | ro              | ro                |
| 7                | 4 3             | 0                 |
|                  | LDN             | LDRN              |
|                  | ro              | ro                |

| Field | Bits  | Type | Description   |
|-------|-------|------|---|
| OUI   | 15:10 | RO   | <b>Organizationally Unique Identifier Bits 19:24</b><br>This register holds the bits 19:24 of the OUI code for MaxLinear Inc., which is specified to be OUI=AC-9A-96. |
| LDN   | 9:4   | RO   | <b>Device Number</b><br>Specifies the device number to distinguish between several different products.  |

| Field | Bits | Type | Description   |
|-------|------|------|---|
| LDRN  | 3:0  | RO   | <b>Device Revision Number</b><br>Specifies the device revision number to distinguish between several versions of this device. |

**Auto-Negotiation Advertisement**

This register contains the advertised abilities of the PHY during auto-negotiation. Refer also to IEEE 802.3 28.2.4.1.3, as well as IEEE 802.3 Table 28-2.

| AN_ADV                         |            |           | Offset          | Reset Value       |
|--------------------------------|------------|-----------|-----------------|-------------------|
| Auto-Negotiation Advertisement |            |           | 04 <sub>H</sub> | 01E1 <sub>H</sub> |
| 15                             | 14         | 13        | 12              | 8                 |
| <b>NP</b>                      | <b>RES</b> | <b>RF</b> |                 | <b>TAF</b>        |
| rw                             | ro         | rw        |                 | rw                |
| 7                              |            | 5         | 4               | 0                 |
|                                | <b>TAF</b> |           |                 | <b>SF</b>         |
|                                | rw         |           |                 | rw                |

| Field | Bits | Type | Description  |
|-------|------|------|--|
| NP    | 15   | RW   | <b>Next Page</b><br>Next-page indication is encoded in bit AN_ADV.NP regardless of the selector field value or link code word encoding. The PHY always advertises NP when a 1000BASE-T mode is advertised during auto-negotiation. Refer to IEEE 802.3 28.2.1.2.6.<br>0 <sub>B</sub> <b>INACTIVE</b> No next page(s) follow(s)<br>1 <sub>B</sub> <b>ACTIVE</b> Additional next page(s) follow(s) |
| RES   | 14   | RO   | <b>Reserved</b><br>Write as zero, ignore on read.  |
| RF    | 13   | RW   | <b>Remote Fault</b><br>The remote fault bit allows indication of a fault to the link partner. Refer to IEEE 802.3 28.2.1.2.4.<br>0 <sub>B</sub> <b>NONE</b> No remote fault is indicated<br>1 <sub>B</sub> <b>FAULT</b> A remote fault is indicated  |

| Field | Bits | Type | Description  |
|-------|------|------|--|
| TAF   | 12:5 | RW   | <p><b>Technology Ability Field</b></p> <p>The technology ability field is an eight-bit wide field containing information indicating supported technologies as defined by the following constants specific to the selector field value. These bits are mapped to individual technologies so that abilities are advertised in parallel for a single selector field value. In converter mode, the field is always forced to value 0x60. The TAF encoding for the IEEE 802.3 selector (AN_ADV.SF=0x1) is described in IEEE 802.3 Annex 28B.2 and in Annex 28D. Refer also to IEEE 802.3 28.2.1.2.2.</p> <p>00000001<sub>B</sub><b>XBT_HDX</b> Advertise 10BASE-T half duplex<br/>           00000010<sub>B</sub><b>XBT_FDX</b> Advertise 10BASE-T full duplex<br/>           00000100<sub>B</sub><b>DBT_HDX</b> Advertise 100BASE-TX half duplex<br/>           00001000<sub>B</sub><b>DBT_FDX</b> Advertise 100BASE-TX full duplex<br/>           00010000<sub>B</sub><b>DBT4</b> Advertise 100BASE-T4<br/>           00100000<sub>B</sub><b>PS_SYM</b> Advertise symmetric pause<br/>           01000000<sub>B</sub><b>PS_ASYM</b> Advertise asymmetric pause<br/>           10000000<sub>B</sub><b>RES</b> Reserved for future technologies</p> |
| SF    | 4:0  | RW   | <p><b>Selector Field</b></p> <p>The selector field is a five-bit wide field for encoding 32 possible messages. Selector field encoding definitions are shown in IEEE 802.3 Annex 28A. Combinations not specified are reserved for future use. Reserved combinations of the selector field are not to be transmitted. Refer also to IEEE 802.3 28.2.1.2.1.</p> <p>00001<sub>B</sub><b>IEEE802DOT3</b> Select the IEEE 802.3 technology</p>  |

### Auto-Negotiation Link-Partner Ability

All of the bits in the auto-negotiation link-partner ability register are read-only. A write to the auto-negotiation link-partner ability register has no effect. This register contains the advertised ability of the link partner. Refer to IEEE 802.3 Tables 28-3 and 28-4. The bit definitions are a direct representation of the received link-code word. Refer to IEEE 802.3 Figure 28-7 and IEEE 802.3 22.2.4.3.3.

| AN_LPA                                |            |           | Offset          | Reset Value       |
|---------------------------------------|------------|-----------|-----------------|-------------------|
| Auto-Negotiation Link-Partner Ability |            |           | 05 <sub>H</sub> | 0000 <sub>H</sub> |
| 15                                    | 14         | 13        | 12              | 8                 |
| <b>NP</b>                             | <b>ACK</b> | <b>RF</b> |                 | <b>TAF</b>        |
| ro                                    | ro         | ro        |                 | ro                |
| 7                                     |            | 5         | 4               | 0                 |
|                                       | <b>TAF</b> |           |                 | <b>SF</b>         |
|                                       | ro         |           |                 | ro                |

| Field | Bits | Type | Description  |
|-------|------|------|--|
| NP    | 15   | RO   | <b>Next Page</b><br>Next-page request indication from the link partner. Refer to IEEE 802.3 28.2.1.2.6.<br>0 <sub>B</sub> <b>INACTIVE</b> No next page(s) follow (s)<br>1 <sub>B</sub> <b>ACTIVE</b> Additional next pages follow (s)  |
| ACK   | 14   | RO   | <b>Acknowledge</b><br>Acknowledgment indication from the link partner's link-code word. Refer to IEEE 802.3 28.2.1.2.5.<br>0 <sub>B</sub> <b>INACTIVE</b> The device did not successfully receive its link partner's link code word<br>1 <sub>B</sub> <b>ACTIVE</b> The device has successfully received its link partner's link-code word   |
| RF    | 13   | RO   | <b>Remote Fault</b><br>Remote fault indication from the link partner. Refer to IEEE 802.3 28.2.1.2.4.<br>0 <sub>B</sub> <b>NONE</b> Remote fault is not indicated by the link partner<br>1 <sub>B</sub> <b>FAULT</b> Remote fault is indicated by the link partner   |
| TAF   | 12:5 | RO   | <b>Technology Ability Field</b><br>Indicates the link-partner capabilities as received from the link partner's link-code word. Refer to IEEE 802.3 28.2.1.2.2.<br><br>00000001 <sub>B</sub> <b>XBT_HDX</b> Link partner advertised 10BASE-T half duplex<br>00000010 <sub>B</sub> <b>XBT_FDX</b> Link partner advertised 10BASE-T full duplex.<br>00000100 <sub>B</sub> <b>DBT_HDX</b> Link partner advertised 100BASE-TX half duplex<br>00001000 <sub>B</sub> <b>DBT_FDX</b> Link partner advertised 100BASE-TX full duplex<br>00010000 <sub>B</sub> <b>DBT4</b> Link partner advertised 100BASE-T4<br>00100000 <sub>B</sub> <b>PS_SYM</b> Link partner advertised symmetric pause<br>01000000 <sub>B</sub> <b>PS_ASYM</b> Link partner advertised asymmetric pause<br>10000000 <sub>B</sub> <b>RES</b> Reserved for future technologies; must be zero |
| SF    | 4:0  | RO   | <b>Selector Field</b><br>The selector field represents one of the 32 possible messages. It must fit to the advertised selector field in AN_ADV.SF. Selector field encoding definitions are shown in IEEE 802.3 Annex 28A.<br><br>00001 <sub>B</sub> <b>IEEE802DOT3</b> Select the IEEE 802.3 technology  |

**Auto-Negotiation Expansion**

This is the auto-negotiation expansion register indicating the status of the link partner's auto-negotiation. Refer to IEEE 802.3 28.2.4.1.5.

| AN_EXP                     | Offset          | Reset Value       |
|----------------------------|-----------------|-------------------|
| Auto-Negotiation Expansion | 06 <sub>H</sub> | 0004 <sub>H</sub> |
| 15                         |                 | 8                 |
| <b>RESD</b>                |                 |                   |
| ro                         |                 |                   |
| 7                          | 5               | 4                 |
| 3                          | 2               | 1                 |
| 0                          |                 |                   |
| <b>RESD</b>                | <b>PDF</b>      | <b>LPNPC</b>      |
| <b>NPC</b>                 | <b>PR</b>       | <b>LPANC</b>      |
| ro                         | rolh            | ro                |
| ro                         | rolh            | ro                |

| Field | Bits | Type | Description   |
|-------|------|------|---|
| RESD  | 15:5 | RO   | <b>Reserved</b><br>Write as zero, ignore on read.   |
| PDF   | 4    | ROLH | <b>Parallel Detection Fault</b><br>This bit latches high. It is set to zero upon read of AN_EXP. Refer to IEEE 802.3 28.2.4.1.5.<br>0 <sub>B</sub> <b>NONE</b> A fault has not been detected via the parallel detection function<br>1 <sub>B</sub> <b>FAULT</b> A fault has been detected via the parallel detection function |
| LPNPC | 3    | RO   | <b>Link Partner Next-Page Capable</b><br>Refer to IEEE 802.3 28.2.4.1.5.<br>0 <sub>B</sub> <b>UNABLE</b> Link partner is unable to exchange next pages<br>1 <sub>B</sub> <b>CAPABLE</b> Link partner is capable of exchanging next pages  |
| NPC   | 2    | RO   | <b>Next-Page Capable</b><br>Refer to IEEE 802.3 28.2.4.1.5.<br>0 <sub>B</sub> <b>UNABLE</b> Local Device is unable to exchange next pages<br>1 <sub>B</sub> <b>CAPABLE</b> Local device is capable of exchanging next pages   |
| PR    | 1    | ROLH | <b>Page Received</b><br>This bit latches high. It is set to zero upon read of AN_EXP. Refer to IEEE 802.3 28.2.4.1.5.<br>0 <sub>B</sub> <b>NONE</b> A new page has not been received<br>1 <sub>B</sub> <b>RECEIVED</b> A new page has been received   |
| LPANC | 0    | RO   | <b>Link Partner Auto-Negotiation Capable</b><br>Refer to IEEE 802.3 28.2.4.1.5.<br>0 <sub>B</sub> <b>UNABLE</b> Link partner is unable to auto-negotiate<br>1 <sub>B</sub> <b>CAPABLE</b> Link partner is auto-negotiation capable  |

**Auto-Negotiation Next-Page Transmit Register**

The auto-negotiation next-page transmit register contains the next-page link-code word to be transmitted when next-page ability is supported. On power-up, this register contains the default value of 0x2001, which represents a message page with the message code set to the null message. Refer also to IEEE 802.3 28.2.4.1.6.

|   |                       |                         |
|---|-----------------------|-------------------------|
| <b>AN_NPTX</b>                                      | <b>Offset</b>         | <b>Reset Value</b>      |
| <b>Auto-Negotiation Next-Page Transmit Register</b> | <b>07<sub>H</sub></b> | <b>2001<sub>H</sub></b> |

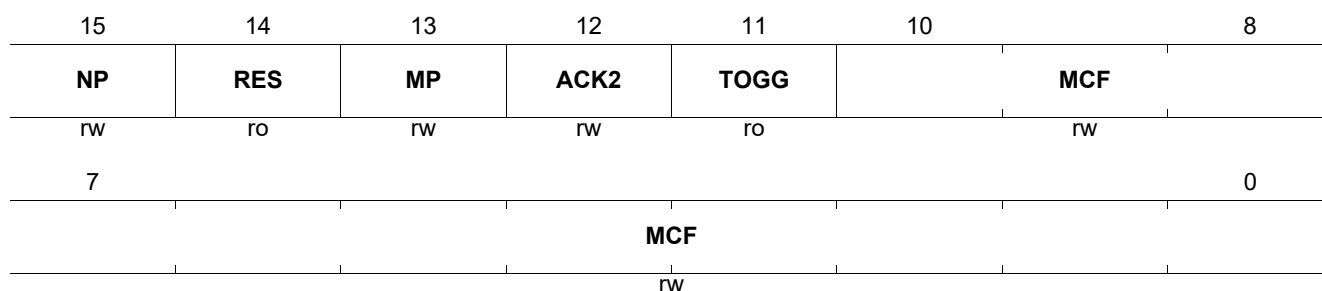

| Field | Bits | Type | Description  |
|-------|------|------|--|
| NP    | 15   | RW   | <b>Next Page</b><br>Refer to IEEE 802.3 28.2.3.4.<br>0 <sub>B</sub> <b>INACTIVE</b> Last page<br>1 <sub>B</sub> <b>ACTIVE</b> Additional next page(s) follow(s)  |
| RES   | 14   | RO   | <b>Reserved</b><br>Write as zeros, ignore on read.   |
| MP    | 13   | RW   | <b>Message Page</b><br>Indicates that the content of MCF is either an unformatted page or a formatted message. Refer to IEEE 802.3 28.2.3.4.<br>0 <sub>B</sub> <b>UNFOR</b> Unformatted page<br>1 <sub>B</sub> <b>MESSG</b> Message page                   |
| ACK2  | 12   | RW   | <b>Acknowledge 2</b><br>Refer to IEEE 802.3 28.2.3.4.<br>0 <sub>B</sub> <b>INACTIVE</b> Device cannot comply with message<br>1 <sub>B</sub> <b>ACTIVE</b> Device complies with message   |
| TOGG  | 11   | RO   | <b>Toggle</b><br>Refer to IEEE 802.3 28.2.3.4.<br>0 <sub>B</sub> <b>ZERO</b> Previous value of the transmitted link-code word was equal to logic ONE<br>1 <sub>B</sub> <b>ONE</b> Previous value of the transmitted link-code word was equal to logic ZERO |
| MCF   | 10:0 | RW   | <b>Message or Unformatted Code Field</b><br>Refer to IEEE 802.3 28.2.3.4.  |

**Auto-Negotiation Link-Partner Received Next-Page Register**

The auto-negotiation link-partner received next-page register contains the next-page link-code word received from the link partner. Refer to IEEE 802.3 28.2.4.1.7.

| AN_NPRX   |            | Offset          |             | Reset Value       |            |   |
|---|------------|-----------------|-------------|-------------------|------------|---|
| Auto-Negotiation Link-Partner Received Next-Page Register |            | 08 <sub>H</sub> |             | 2001 <sub>H</sub> |            |   |
| 15  | 14         | 13              | 12          | 11                | 10         | 8 |
| <b>NP</b>   | <b>ACK</b> | <b>MP</b>       | <b>ACK2</b> | <b>TOGG</b>       | <b>MCF</b> |   |
| ro  | ro         | ro              | ro          | ro                | ro         |   |
| 7   |            |                 |             |                   |            | 0 |
| <b>MCF</b>  |            |                 |             |                   |            |   |
| ro  |            |                 |             |                   |            |   |

| Field | Bits | Type | Description  |
|-------|------|------|--|
| NP    | 15   | RO   | <b>Next Page</b><br>Refer to IEEE 802.3 28.2.3.4.<br>0 <sub>B</sub> <b>INACTIVE</b> No next pages to follow<br>1 <sub>B</sub> <b>ACTIVE</b> Additional next page(s) follow(s)  |
| ACK   | 14   | RO   | <b>Acknowledge</b><br>Refer to IEEE 802.3 28.2.3.4.<br>0 <sub>B</sub> <b>INACTIVE</b> The device did not successfully receive its link partner's link-code word<br>1 <sub>B</sub> <b>ACTIVE</b> The device has successfully received its link partner's link-code word |
| MP    | 13   | RO   | <b>Message Page</b><br>Indicates that the content of MCF is either an unformatted page or a formatted message. Refer to IEEE 802.3 28.2.3.4.<br>0 <sub>B</sub> <b>UNFOR</b> Unformatted page<br>1 <sub>B</sub> <b>MESSG</b> Message page                               |
| ACK2  | 12   | RO   | <b>Acknowledge 2</b><br>Refer to IEEE 802.3 28.2.3.4.<br>0 <sub>B</sub> <b>INACTIVE</b> Device cannot comply with message<br>1 <sub>B</sub> <b>ACTIVE</b> Device complies with message   |
| TOGG  | 11   | RO   | <b>Toggle</b><br>Refer to IEEE 802.3 28.2.3.4.<br>0 <sub>B</sub> <b>ZERO</b> Previous value of the transmitted link-code word was equal to logic ONE<br>1 <sub>B</sub> <b>ONE</b> Previous value of the transmitted link-code word was equal to logic ZERO             |
| MCF   | 10:0 | RO   | <b>Message or Unformatted Code Field</b><br>Refer to IEEE 802.3 28.2.3.4.  |



**Gigabit Control Register**

This is the control register used to configure the Gigabit Ethernet behavior of the PHY. Refer to IEEE 802.3 40.5.1.1.

| GCTRL                    | Offset          |             |           |             |              |              | Reset Value       |
|--------------------------|-----------------|-------------|-----------|-------------|--------------|--------------|-------------------|
| Gigabit Control Register | 09 <sub>H</sub> |             |           |             |              |              | 0300 <sub>H</sub> |
| 15                       | 13              | 12          | 11        | 10          | 9            | 8            |                   |
|                          | <b>TM</b>       | <b>MSEN</b> | <b>MS</b> | <b>MSPT</b> | <b>MBTFD</b> | <b>MBTHD</b> |                   |
|                          | rw              | rw          | rw        | rw          | rw           | rw           |                   |
| 7                        | <b>RES</b>      |             |           |             |              |              | 0                 |
|                          | ro              |             |           |             |              |              |                   |

| Field | Bits  | Type | Description  |
|-------|-------|------|--|
| TM    | 15:13 | RW   | <b>Transmitter Test Mode</b><br>This register field allows enabling of the standard transmitter test modes. Refer also to IEEE 802.3-2008 Table 40-7.<br><br>000 <sub>B</sub> <b>NOP</b> Normal operation<br>001 <sub>B</sub> <b>WAV</b> Test mode 1 transmit waveform test<br>010 <sub>B</sub> <b>JITM</b> Test mode 2 transmit jitter test in MASTER mode<br>011 <sub>B</sub> <b>JITS</b> Test mode 3 transmit jitter test in SLAVE mode<br>100 <sub>B</sub> <b>DIST</b> Test mode 4 transmitter distortion test<br>101 <sub>B</sub> <b>RES0</b> Reserved, operations not identified.<br>110 <sub>B</sub> <b>CDIAG</b> Cable diagnostics.<br>111 <sub>B</sub> <b>ABIST</b> Analog build in self-test |
| MSEN  | 12    | RW   | <b>Master/Slave Manual Configuration Enable</b><br>Refer also to IEEE 802.3-2008 40.5.1.1.<br>0 <sub>B</sub> <b>DISABLED</b> Disable master/slave manual configuration value<br>1 <sub>B</sub> <b>ENABLED</b> Enable master/slave manual configuration value   |
| MS    | 11    | RW   | <b>Master/Slave Config Value</b><br>Allows forcing of master or slave mode manually when AN_GCTRL.MSEN is set to logical one. Refer also to IEEE 802.3-2008 40.5.1.1.<br>0 <sub>B</sub> <b>SLAVE</b> Configure PHY as SLAVE during master/slave negotiation, only when AN_GCTRL.MSEN is set to logical one<br>1 <sub>B</sub> <b>MASTER</b> Configure PHY as MASTER during master/slave negotiation, only when AN_GCTRL.MSEN is set to logical one  |
| MSPT  | 10    | RW   | <b>Master/Slave Port Type</b><br>Defines whether the PHY advertises itself as a multi- or single-port device, which in turn impacts the master/slave resolution function. Refer also to IEEE 802.3-2008 40.5.1.1.<br>0 <sub>B</sub> <b>SPD</b> Single-port device<br>1 <sub>B</sub> <b>MPD</b> Multi-port device   |

| Field | Bits | Type | Description  |
|-------|------|------|--|
| MBTFD | 9    | RW   | <b>1000BASE-T Full-Duplex</b><br>Advertises the 1000BASE-T full-duplex capability; always forced to 1 in converter mode. Refer also to IEEE 802.3 40.5.1.1.<br>0 <sub>B</sub> <b>DISABLED</b> Advertise PHY as not 1000BASE-T full-duplex capable<br>1 <sub>B</sub> <b>ENABLED</b> Advertise PHY as 1000BASE-T full-duplex capable |
| MBTHD | 8    | RW   | <b>1000BASE-T Half-Duplex</b><br>Advertises the 1000BASE-T half-duplex capability; always forced to 1 in converter mode. Refer to IEEE 802.3 40.5.1.1.<br>0 <sub>B</sub> <b>DISABLED</b> Advertise PHY as not 1000BASE-T half-duplex capable<br>1 <sub>B</sub> <b>ENABLED</b> Advertise PHY as 1000BASE-T half-duplex capable      |
| RES   | 7:0  | RO   | <b>Reserved</b><br>Write as zero, ignore on read.  |

**Gigabit Status Register**

This is the status register used to reflect the Gigabit Ethernet status of the PHY. Refer also to IEEE 802.3-2008 40.5.1.1.

| GSTAT                   |              |                |                |              |              |            | Offset          | Reset Value       |
|-------------------------|--------------|----------------|----------------|--------------|--------------|------------|-----------------|-------------------|
| Gigabit Status Register |              |                |                |              |              |            | 0A <sub>H</sub> | 0000 <sub>H</sub> |
| 15                      | 14           | 13             | 12             | 11           | 10           | 9          | 8               |                   |
| <b>MSFAULT</b>          | <b>MSRES</b> | <b>LRXSTAT</b> | <b>RRXSTAT</b> | <b>MBTFD</b> | <b>MBTHD</b> | <b>RES</b> |                 |                   |
| rolh                    | ro           | ro             | ro             | ro           | ro           | ro         |                 |                   |
| 7                       |              |                |                |              |              |            | 0               |                   |
|                         |              |                |                |              |              |            | <b>IEC</b>      |                   |
|                         |              |                |                |              |              |            | rosc            |                   |

| Field   | Bits | Type | Description   |
|---------|------|------|---|
| MSFAULT | 15   | ROLH | <b>Master/Slave Manual Configuration Fault</b><br>This is a latching high bit. It is cleared upon each read of GSTAT. This bit self clears on auto-negotiation enable or auto-negotiation complete. This bit is set to active high when the number of failed master/slave resolutions reaches 7. Refer also to IEEE 802.3-2008 40.5.1.1 register 10 in Table 40-3.<br>0 <sub>B</sub> <b>OK</b> Master/slave manual configuration resolved successfully<br>1 <sub>B</sub> <b>NOK</b> Master/slave manual configuration resolved with a fault |
| MSRES   | 14   | RO   | <b>Master/Slave Configuration Resolution</b><br>Refer to IEEE 802.3 40.5.1.1 register 10 in Table 40-3.<br>0 <sub>B</sub> <b>SLAVE</b> Local PHY configuration resolved to SLAVE<br>1 <sub>B</sub> <b>MASTER</b> Local PHY configuration resolved to MASTER   |

| Field   | Bits | Type | Description  |
|---------|------|------|--|
| LRXSTAT | 13   | RO   | <b>Local Receiver Status</b><br>Indicates the status of the local receiver. Refer also to IEEE 802.3-2008 40.5.1.1 register 10 in Table 40-3.<br>0 <sub>B</sub> <b>NOK</b> Local receiver not OK<br>1 <sub>B</sub> <b>OK</b> Local receiver OK   |
| RRXSTAT | 12   | RO   | <b>Remote Receiver Status</b><br>Indicates the status of the remote receiver. Refer also to IEEE 802.3-2008 40.5.1.1 register 10 in Table 40-3.<br><b>Constants</b><br>0 <sub>B</sub> <b>NOK</b> Remote receiver not OK<br>1 <sub>B</sub> <b>OK</b> Remote receiver OK   |
| MBTFD   | 11   | RO   | <b>Link-Partner Capable of Operating 1000BASE-T Full-Duplex</b><br>Refer also to IEEE 802.3-2008 40.5.1.1 register 10 in Table 40-3.<br><b>Constants</b><br>0 <sub>B</sub> <b>DISABLED</b> Link partner is not capable of operating 1000BASE-T full-duplex<br>1 <sub>B</sub> <b>ENABLED</b> Link partner is capable of operating 1000BASE-T full-duplex  |
| MBTHD   | 10   | RO   | <b>Link-Partner Capable of Operating 1000BASE-T Half-Duplex</b><br>Refer also to IEEE 802.3-2008 40.5.1.1 register 10 in Table 40-3.<br><b>Constants</b><br>0 <sub>B</sub> <b>DISABLED</b> Link partner is not capable of operating 1000BASE-T half-duplex<br>1 <sub>B</sub> <b>ENABLED</b> Link partner is capable of operating 1000BASE-T half-duplex  |
| RES     | 9:8  | RO   | <b>Reserved</b><br>Write as zero, ignore on read.  |
| IEC     | 7:0  | ROSC | <b>Idle Error Count</b><br>Indicates the idle error count. This field contains a cumulative count of the errors detected when the receiver is receiving idles and PMA_TXMODE. Indicate is equal to SEND_N (indicating that both local and remote receiver status have been detected to be OK). The counter is incremented every symbol period that rxerror_status is equal to ERROR. These bits are reset to all zeros when the GSTAT register is read by the management function or upon execution of the PCS reset function, and are to be held at all ones in case of overflow. |

**Reserved**

Reserved. In IEEE 802.3-2008, this register is used for Power-Sourcing-Equipment (PSE) control functions. Refer to IEEE 802.3-2008 33.6.1.1. These are not supported by this PHY.

| RES11    | Offset          | Reset Value       |
|----------|-----------------|-------------------|
| Reserved | 0B <sub>H</sub> | 0000 <sub>H</sub> |
| 15       |                 | 8                 |
|          | RES             |                   |
|          | ro              |                   |
| 7        |                 | 0                 |
|          | RES             |                   |
|          | ro              |                   |

| Field | Bits | Type | Description  |
|-------|------|------|--|
| RES   | 15:0 | RO   | <b>Reserved</b><br>Write as zero, ignored on read. |

**Reserved**

Reserved. In IEEE 802.3-2008, this register is used for Power-Sourcing-Equipment (PSE) status functions. Refer to IEEE 802.3-2008 33.6.1.2. These are not supported by this PHY.

| RES12    | Offset          | Reset Value       |
|----------|-----------------|-------------------|
| Reserved | 0C <sub>H</sub> | 0000 <sub>H</sub> |
| 15       |                 | 8                 |
|          | RES             |                   |
|          | ro              |                   |
| 7        |                 | 0                 |
|          | RES             |                   |
|          | ro              |                   |

| Field | Bits | Type | Description  |
|-------|------|------|--|
| RES   | 15:0 | RO   | <b>Reserved</b><br>Write as zero, ignored on read. |

**MMD Access Control Register**

The MMD access control register is used in conjunction with the MMDDATA register to access the MMD register space. Each MMD maintains its own individual address register, as described in IEEE 802.3-2008 clause 45.2.8. The DEVAD field directs any accesses of register MMDDATA to the appropriate MMD as described in IEEE 802.3-2008 clause 45.2. For additional insight into the operation and use of the MMD registers, refer to IEEE 802.3-2008 clause 22.2.4.3.11, Annex 22D and clause 45.2.

| MMDCTRL                     | Offset          | Reset Value       |       |
|-----------------------------|-----------------|-------------------|-------|
| MMD Access Control Register | 0D <sub>H</sub> | 0000 <sub>H</sub> |       |
| 15                          | 14              | 13                | 8     |
| ACTYPE                      |                 |                   | RESH  |
| rw                          |                 |                   | ro    |
| 7                           | 5               | 4                 | 0     |
|                             | RESL            |                   | DEVAD |
|                             | ro              |                   | rw    |

| Field  | Bits  | Type | Description  |
|--------|-------|------|--|
| ACTYPE | 15:14 | RW   | <b>Access Type Function</b><br>When the access of register MMDDATA is an address access (ACTYPE=0) then it is directed to the address register within the MMD associated with the value in the DEVAD field. Otherwise, both the DEVAD field and the MMD's address register direct the register MMDDATA data accesses to the appropriate registers within that MMD. The function field can be set to any of the constants defined (ADDRESS, DATA, DATA_PI, DATA_PIWR).<br><br>00 <sub>B</sub> <b>ADDRESS</b> Accesses to register MMDDATA access the MMD individual address register<br>01 <sub>B</sub> <b>DATA</b> Accesses to register MMDDATA access the register within the MMD selected by the value in the MMD address register<br>10 <sub>B</sub> <b>DATA_PI</b> Accesses to register MMDDATA access the register within the MMD selected by the value in the MMD address register. After this access is complete, for both read and write accesses, the value in the MMD address field is incremented.<br>11 <sub>B</sub> <b>DATA_PIWR</b> Accesses to register MMDDATA access the register within the MMD selected by the value in the MMD address register. After this access is complete, for write accesses only, the value in the MMD address field is incremented. For read accesses, the value in the MMD address field is not modified. |
| RESH   | 13:8  | RO   | <b>Reserved</b><br>Write as zero, ignored on read.   |
| RESL   | 7:5   | RO   | <b>Reserved</b><br>Write as zero, ignored on read.   |

| Field | Bits | Type | Description   |
|-------|------|------|---|
| DEVAD | 4:0  | RW   | <b>Device Address</b><br>The DEVAD field directs any accesses of register MMDDATA to the appropriate MMD as described in IEEE 802.3-2008 clause 45.2. |

**MMD Access Data Register**

The MMD access data register is used in conjunction with the MMD access control (MMDCTRL) register to access the MMD register space. For more information on MMD access, refer to IEEE 802.3-2008 clause 22.2.4.3.12, clause 45.2 and Annex 22D.

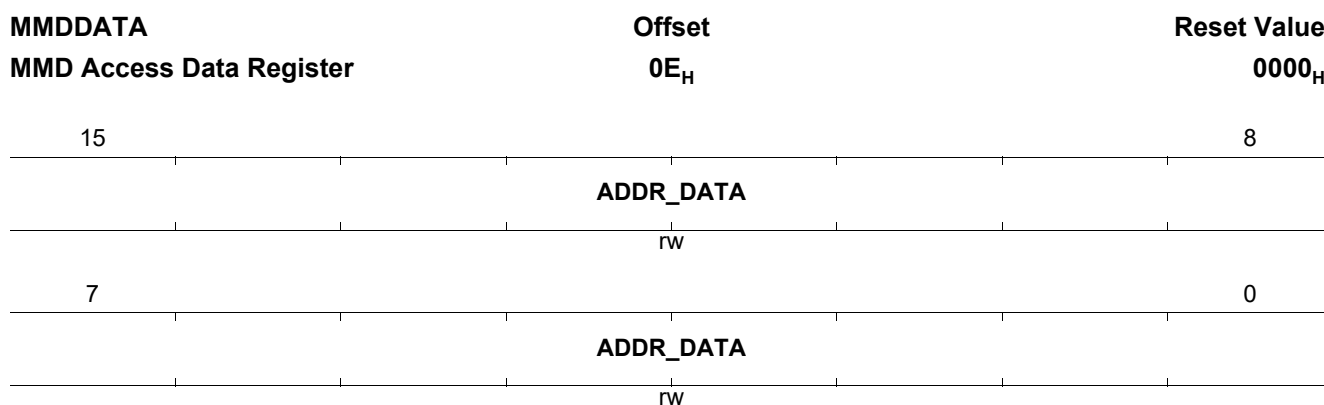

| Field     | Bits | Type | Description   |
|-----------|------|------|---|
| ADDR_DATA | 15:0 | RW   | <b>Address or Data Register</b><br>This register accesses either a specific MMD address register or the data content of the MMD register to which this address register points. Which of the functions is currently valid is defined by the MMDCTRL register. |

**Extended Status Register**

This register contains extended status and capability information about the PHY. All bits are read-only. A write access does not have any effect.

| XSTAT                    |             | Offset          |             | Reset Value       |             |
|--------------------------|-------------|-----------------|-------------|-------------------|-------------|
| Extended Status Register |             | 0F <sub>H</sub> |             | 3000 <sub>H</sub> |             |
| 15                       | 14          | 13              | 12          | 11                | 8           |
| <b>MBXF</b>              | <b>MBXH</b> | <b>MBTF</b>     | <b>MBTH</b> |                   | <b>RESH</b> |
| ro                       | ro          | ro              | ro          |                   | ro          |
| 7                        |             |                 |             |                   | 0           |
|                          |             |                 | <b>RESL</b> |                   |             |
|                          |             |                 | ro          |                   |             |

| Field | Bits | Type | Description  |
|-------|------|------|--|
| MBXF  | 15   | RO   | <b>1000BASE-X Full-Duplex Capability</b><br>Specifies whether the PHY is capable of operating 1000BASE-X full-duplex.<br>0 <sub>B</sub> <b>DISABLED</b> PHY does not support this mode<br>1 <sub>B</sub> <b>ENABLED</b> PHY supports this mode |
| MBXH  | 14   | RO   | <b>1000BASE-X Half-Duplex Capability</b><br>Specifies whether the PHY is capable of operating 1000BASE-X half-duplex.<br>0 <sub>B</sub> <b>DISABLED</b> PHY does not support this mode<br>1 <sub>B</sub> <b>ENABLED</b> PHY supports this mode |
| MBTF  | 13   | RO   | <b>1000BASE-T Full-Duplex Capability</b><br>Specifies whether the PHY is capable of operating 1000BASE-T full-duplex.<br>0 <sub>B</sub> <b>DISABLED</b> PHY does not support this mode<br>1 <sub>B</sub> <b>ENABLED</b> PHY supports this mode |
| MBTH  | 12   | RO   | <b>1000BASE-T Half-Duplex Capability</b><br>Specifies whether the PHY is capable of operating 1000BASE-T full-duplex.<br>0 <sub>B</sub> <b>DISABLED</b> PHY does not support this mode<br>1 <sub>B</sub> <b>ENABLED</b> PHY supports this mode |
| RESH  | 11:8 | RO   | <b>Reserved</b><br>Ignore when read.   |
| RESL  | 7:0  | RO   | <b>Reserved</b><br>Ignore when read.   |

### 4.3.2 PHY: PHY-Specific Management Registers

This section describes the PHY-specific management registers.

#### Physical Layer Performance Status

This register reports the PHY performance in the current mode of operation. The content of this register is only valid when the link is up.

| PHYPERF                           | Offset          | Reset Value       |
|-----------------------------------|-----------------|-------------------|
| Physical Layer Performance Status | 10 <sub>H</sub> | 80FF <sub>H</sub> |
| 15                                |                 | 8                 |
| FREQ                              |                 |                   |
|                                   | ro              |                   |
| 7                                 | 4               | 3                 |
|                                   | ro              | ro                |
|                                   | SNR             | LEN               |
|                                   | ro              | ro                |

| Field | Bits | Type | Description   |
|-------|------|------|---|
| FREQ  | 15:8 | RO   | <b>Frequency Offset of Link-Partner [ppm]</b><br>This register fields reports the measured frequency offset of the receiver in ppm as a signed 2's complement number. A value of -128 (0x80) indicates an invalid number.   |
| SNR   | 7:4  | RO   | <b>Receive SNR Margin [dB]</b><br>This register field reports the measured SNR margin of the receiver in dB. The value saturates at a 14-dB SNR margin for very short links and 0 dB for very long links. A value of 15 indicates an invalid number.<br>1111 <sub>B</sub> INVALID Invalid value |
| LEN   | 3:0  | RO   | <b>Estimated Loop Length (Valid During Link-Up)</b><br>This register field reports the estimated loop length compared to a virtually ideal CAT5e straight cable. The unit is LEN x 10m. A value of 15 indicates an invalid number.  |



**Physical Layer Status 1**

This register reports PHY lock information, for example link-up, polarity reversals and port mapping. The content of this register is only valid when the link is up.

| PHYSTAT1                |      |      |      |       |       |      | Offset          | Reset Value       |
|-------------------------|------|------|------|-------|-------|------|-----------------|-------------------|
| Physical Layer Status 1 |      |      |      |       |       |      | 11 <sub>H</sub> | 0000 <sub>H</sub> |
|                         |      |      |      |       |       |      | 9               | 8                 |
| RESH                    |      |      |      |       |       |      | LSADS           |                   |
|                         |      |      |      |       |       |      | ro              | rosc              |
| 7                       | 6    | 5    | 4    | 3     | 2     | 1    | 0               |                   |
| POLD                    | POLC | POLB | POLA | MDICD | MDIAB | RESL |                 |                   |
| ro                      | ro   | ro   | ro   | ro    | ro    | ro   |                 |                   |

| Field | Bits | Type | Description  |
|-------|------|------|--|
| RESH  | 15:9 | RO   | <b>Reserved</b><br>Write as zero, ignored on read.   |
| LSADS | 8    | ROSC | <b>Link-Speed Auto-Downspeed Status</b><br>Monitors the status of the link speed auto-downspeed controlled in PHYCTL1.LDADS<br>0 <sub>B</sub> <b>NORMAL</b> Did not perform any link speed auto-downspeed<br>1 <sub>B</sub> <b>DETECTED</b> Detected an auto-downspeed |
| POLD  | 7    | RO   | <b>Receive Polarity Inversion Status on Port D</b><br>0 <sub>B</sub> <b>NORMAL</b> Polarity normal<br>1 <sub>B</sub> <b>INVERTED</b> Polarity inversion detected   |
| POLC  | 6    | RO   | <b>Receive Polarity Inversion Status on Port C</b><br>0 <sub>B</sub> <b>NORMAL</b> Polarity normal<br>1 <sub>B</sub> <b>INVERTED</b> Polarity inversion detected   |
| POLB  | 5    | RO   | <b>Receive Polarity Inversion Status on Port B</b><br>0 <sub>B</sub> <b>NORMAL</b> Polarity normal<br>1 <sub>B</sub> <b>INVERTED</b> Polarity inversion detected   |
| POLA  | 4    | RO   | <b>Receive Polarity Inversion Status on Port A</b><br>0 <sub>B</sub> <b>NORMAL</b> Polarity normal<br>1 <sub>B</sub> <b>INVERTED</b> Polarity inversion detected   |
| MDICD | 3    | RO   | <b>Mapping of MDI Ports C and D</b><br>0 <sub>B</sub> <b>MDI</b> Normal MDI mode<br>1 <sub>B</sub> <b>MDIX</b> Crossover MDI-X mode  |
| MDIAB | 2    | RO   | <b>Mapping of MDI Ports A and B</b><br>0 <sub>B</sub> <b>MDI</b> Normal MDI mode<br>1 <sub>B</sub> <b>MDIX</b> Crossover MDI-X mode  |
| RESL  | 1:0  | RO   | <b>Reserved</b><br>Write as zero, ignored on read.   |

**Physical Layer Status 2**

This register reports PHY lock information, for example, pair skews in the GbE mode. The content of this register is only valid when the link is up.

| PHYSTAT2                |              | Offset          |              | Reset Value       |   |
|-------------------------|--------------|-----------------|--------------|-------------------|---|
| Physical Layer Status 2 |              | 12 <sub>H</sub> |              | 0000 <sub>H</sub> |   |
| 15                      | 14           | 12              | 11           | 10                | 8 |
| <b>RESD</b>             | <b>SKEWD</b> | <b>RESC</b>     | <b>SKEWC</b> |                   |   |
| ro                      | ro           | ro              | ro           |                   |   |
| 7                       | 6            | 4               | 3            | 2                 | 0 |
| <b>RESB</b>             | <b>SKEWB</b> | <b>RESA</b>     | <b>SKEWA</b> |                   |   |
| ro                      | ro           | ro              | ro           |                   |   |

| Field | Bits  | Type | Description  |
|-------|-------|------|--|
| RESD  | 15    | RO   | <b>Reserved</b><br>Write as zero, ignored on read.   |
| SKEWD | 14:12 | RO   | <b>Receive Skew on Port D</b><br>The skew is reported as an unsigned number of symbol periods. |
| RESC  | 11    | RO   | <b>Reserved</b><br>Write as zero, ignored on read.   |
| SKEWC | 10:8  | RO   | <b>Receive Skew on Port C</b><br>The skew is reported as an unsigned number of symbol periods. |
| RESB  | 7     | RO   | <b>Reserved</b><br>Write as zero, ignored on read.   |
| SKEWB | 6:4   | RO   | <b>Receive Skew on Port B</b><br>The skew is reported as an unsigned number of symbol periods. |
| RESA  | 3     | RO   | <b>Reserved</b><br>Write as zero, ignored on read.   |
| SKEWA | 2:0   | RO   | <b>Receive Skew on Port A</b><br>The skew is reported as an unsigned number of symbol periods. |

**Physical Layer Control 1**

This register controls the PHY functions.

| PHYCTL1                  |      | Offset          |       | Reset Value       |       |         |       |
|--------------------------|------|-----------------|-------|-------------------|-------|---------|-------|
| Physical Layer Control 1 |      | 13 <sub>H</sub> |       | 0003 <sub>H</sub> |       |         |       |
| 15                       | 13   | 12              | 11    | 8                 |       |         |       |
| TLOOP                    |      | TXOFF           | TXADJ |                   |       |         |       |
| rw                       |      | rw              | rw    |                   |       |         |       |
| 7                        | 6    | 5               | 4     | 3                 | 2     | 1       | 0     |
| POLD                     | POLC | POLB            | POLA  | MDICD             | MDIAB | TXEEE10 | AMDIX |
| rw                       | rw   | rw              | rw    | rw                | rw    | ro      | rw    |

| Field | Bits  | Type | Description   |
|-------|-------|------|---|
| TLOOP | 15:13 | RW   | <b>Test Loop</b><br>Configures predefined test loops.<br>000 <sub>B</sub> <b>OFF</b> Test loops are switched off - normal operation.<br>001 <sub>B</sub> <b>NETL</b> Near-end test loop<br>010 <sub>B</sub> <b>FETL</b> Far-end test loop<br>011 <sub>B</sub> <b>ECHO</b> Echo test loop<br>100 <sub>B</sub> <b>RJTL</b> RL45 connector test loop<br>101 <sub>B</sub> <b>FETLS</b> Standalone Far-end test loop. No dependency on TX_CLK and RX_CLK on the (G)MII interface |
| TXOFF | 12    | RW   | <b>Transmitter Off</b><br>This register bit allows turning off of the transmitter. This feature might be useful for return loss measurements.<br>0 <sub>B</sub> <b>ON</b> Transmitter is on<br>1 <sub>B</sub> <b>OFF</b> Transmitter is off   |
| TXADJ | 11:8  | RW   | <b>Transmit Level Adjustment</b><br>Transmit-level adjustment can be used to fine tune the transmit amplitude of the PHY. The amplitude adjustment is valid for all supported speed modes. The adjustment is performed in digits. One digit represents 3.125 percent of the nominal amplitude. The scaling factor is $gain = 1 + signed(TXADJ) * 2^{-7}$ .  |
| POLD  | 7     | RW   | <b>Transmit Polarity Inversion Status on Port D</b><br>0 <sub>B</sub> <b>NORMAL</b> Polarity normal<br>1 <sub>B</sub> <b>INVERTED</b> Polarity inversion  |
| POLC  | 6     | RW   | <b>Transmit Polarity Inversion Status on Port C</b><br>0 <sub>B</sub> <b>NORMAL</b> Polarity normal<br>1 <sub>B</sub> <b>INVERTED</b> Polarity inversion  |
| POLB  | 5     | RW   | <b>Transmit Polarity Inversion Control on Port B</b><br>0 <sub>B</sub> <b>NORMAL</b> Polarity normal<br>1 <sub>B</sub> <b>INVERTED</b> Polarity inversion   |

| Field   | Bits | Type | Description   |
|---------|------|------|---|
| POLA    | 4    | RW   | <b>Transmit Polarity Inversion Control on Port A</b><br>0 <sub>B</sub> <b>NORMAL</b> Polarity normal<br>1 <sub>B</sub> <b>INVERTED</b> Polarity inversion   |
| MDICD   | 3    | RW   | <b>Mapping of MDI Ports C and D</b><br>0 <sub>B</sub> <b>MDI</b> Normal MDI mode<br>1 <sub>B</sub> <b>MDIX</b> Crossover MDI-X mode   |
| MDIAB   | 2    | RW   | <b>Mapping of MDI Ports A and B</b><br>0 <sub>B</sub> <b>MDI</b> Normal MDI mode<br>1 <sub>B</sub> <b>MDIX</b> Crossover MDI-X mode   |
| TXEEE10 | 1    | RO   | <b>Transmit Energy-Efficient Ethernet 10BASE-Te Amplitude</b><br>This register bit allows enabling of the 10BASE-Te energy-efficient mode transmitting only with a 1.75 V nominal amplitude.<br>0 <sub>B</sub> <b>DISABLED</b> Transmit the 10Base-T amplitude, that is, 2.3 V<br>1 <sub>B</sub> <b>ENABLED</b> Transmit the 10BASE-Te amplitude, that is, 1.75 V |
| AMDIX   | 0    | RW   | <b>PHY Performs Auto-MDI/MDI-X or Uses Manual MDI/MDI-X</b><br>0 <sub>B</sub> <b>MANUAL</b> PHY uses manual MDI/MDI-X<br>1 <sub>B</sub> <b>AUTO</b> PHY performs Auto-MDI/MDI-X   |

### Physical Layer Control 2

This register controls the PHY functions.

| PHYCTL2                  | Offset          | Reset Value       |      |        |     |   |
|--------------------------|-----------------|-------------------|------|--------|-----|---|
| Physical Layer Control 2 | 14 <sub>H</sub> | 8006 <sub>H</sub> |      |        |     |   |
| 15                       | 14              | 13                | 9    | 8      |     |   |
| LSADS                    |                 | RESH              |      | STICKY |     |   |
| rw                       |                 | ro                |      | rw     |     |   |
| 7                        | 5               | 4                 | 3    | 2      | 1   | 0 |
| RESL                     |                 | ADCR              | PSCL | ANPD   | Res |   |
| ro                       |                 | rw                | rw   | rw     |     |   |

| Field | Bits  | Type | Description   |
|-------|-------|------|---|
| LSADS | 15:14 | RW   | <b>Link Speed Auto-Downspeed Control Register</b><br>Link speed auto-downspeed is a functionality which allows an Ethernet link to be established even in non-standard harsh cable environments.<br><b>Constants applicable for GSW125-AQM-T device</b><br>00 <sub>B</sub> <b>ADS1</b> Do not perform auto-downspeed of link speed<br>01 <sub>B</sub> <b>ADS2</b> Perform auto-downspeed of link speed after 4 consecutive failed link-ups.<br>10 <sub>B</sub> <b>ADS3</b> Perform auto-downspeed of link speed after 6 consecutive failed link-ups.<br>11 <sub>B</sub> <b>ADS4</b> Perform auto-downspeed of link speed after 8 consecutive failed link-ups. |

| Field  | Bits | Type | Description   |
|--------|------|------|---|
| RESH   | 13:9 | RO   | <b>Reserved</b><br>Write as zero, ignored on read.  |
| STICKY | 8    | RW   | <b>Sticky-Bit Handling</b><br>Allows enabling/disabling of the sticky-bit handling for all PHY-specific MDIO register bits of type RW, except for the TPGCTRL register. This means that the current content of these registers is left untouched during a software reset when sticky-bit handling is enabled.<br>0 <sub>B</sub> <b>OFF</b> Sticky-bit handling is disabled<br>1 <sub>B</sub> <b>ON</b> Sticky-bit handling is enabled |
| RESL   | 7:5  | RO   | <b>Reserved</b><br>Write as zero, ignored on read.  |
| ADCR   | 4:3  | RW   | <b>ADC Resolution Boost</b><br>Allows for the ADC resolution to be increased.<br>00 <sub>B</sub> <b>DEFAULT</b> Default ADC resolution.<br>01 <sub>B</sub> <b>BOOST</b> ADC resolution boost.   |
| PSCL   | 2    | RW   | <b>Power-Consumption Scaling Depending on Link Quality</b><br>Allows enabling/disabling of the power-consumption scaling dependent on the link quality.<br>0 <sub>B</sub> <b>OFF</b> PSCL is disabled<br>1 <sub>B</sub> <b>ON</b> PSCL is enabled   |
| ANPD   | 1    | RW   | <b>Auto-Negotiation Power Down</b><br>Allows enabling/disabling of the power-down modes during auto-negotiation looking for a link partner.<br>0 <sub>B</sub> <b>OFF</b> ANPD is disabled<br>1 <sub>B</sub> <b>ON</b> ANPD is enabled   |

**Error Counter**

This register controls the error counter. It allows the number of errors detected in the PHY to be counted for monitoring purposes.

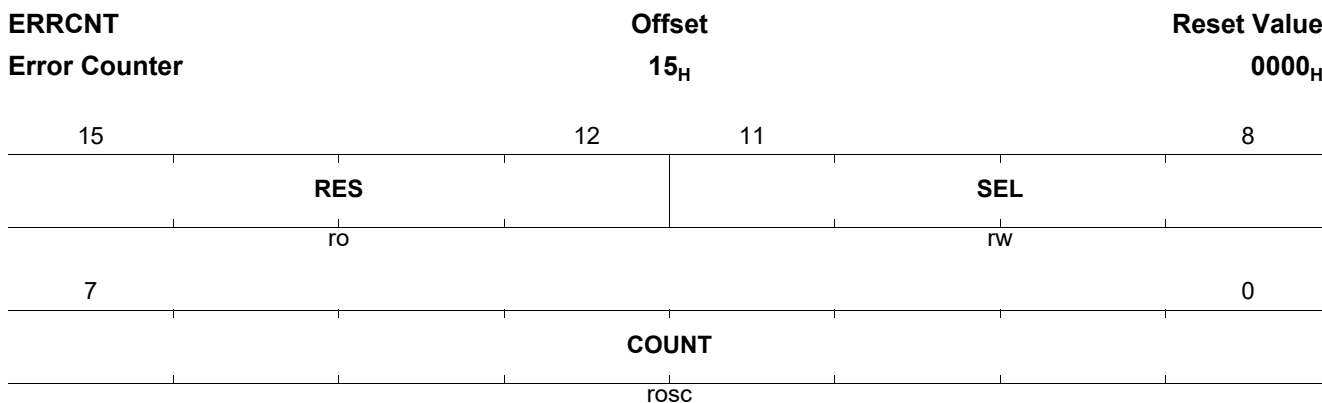

| Field | Bits  | Type | Description   |
|-------|-------|------|---|
| RES   | 15:12 | RO   | <b>Reserved</b><br>Write as zero, ignored on read.  |
| SEL   | 11:8  | RW   | <b>Select Error Event</b><br>Configures the error/event to which the error counter is sensitive.<br>0000 <sub>B</sub> <b>RXERR</b> Receive errors are counted<br>0001 <sub>B</sub> <b>RXACT</b> Receive frames are counted<br>0010 <sub>B</sub> <b>ESDERR</b> ESD errors are counted<br>0011 <sub>B</sub> <b>SSDERR</b> SSD errors are counted<br>0100 <sub>B</sub> <b>TXERR</b> Transmit errors are counted<br>0101 <sub>B</sub> <b>TXACT</b> Transmit frames events get counted<br>0110 <sub>B</sub> <b>COL</b> Collision events get counted<br>1000 <sub>B</sub> <b>NLD</b> Number of Link Down get counted<br>1001 <sub>B</sub> <b>NDS</b> Number of auto-downspeed get counted |
| COUNT | 7:0   | ROSC | <b>Counter State</b><br>This counter state is updated each time the selected error event has been detected. The counter state is reset every time a read operation on this register is performed or the error event is changed. The counter saturates at value 0xFF.  |

**Media-Independent Interface Status**

This register contains status information of the MII interface.

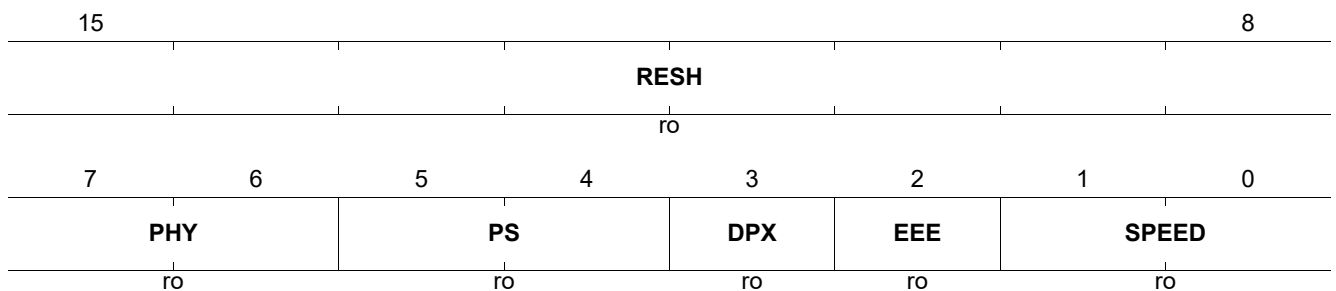
| MIISTAT  | Offset          | Reset Value       |
|--|-----------------|-------------------|
| Media-Independent Interface Status   | 18 <sub>H</sub> | 0000 <sub>H</sub> |
|  |                 |                   |

| Field | Bits | Type | Description   |
|-------|------|------|---|
| RESH  | 15:8 | RO   | <b>Reserved</b><br>Write as zero, ignored on read.  |
| PHY   | 7:6  | RO   | <b>Active PHY Interface</b><br>00 <sub>B</sub> <b>TP</b> The twisted-pair interface is the active PHY interface<br>01 <sub>B</sub> <b>FIBER</b> The fiber interface is the active PHY interface<br>10 <sub>B</sub> <b>MII2</b> The second MII interface is the active PHY interface<br>11 <sub>B</sub> <b>SGMII</b> The SGMII interface is the active PHY interface |
| PS    | 5:4  | RO   | <b>Resolved Pause Status for Flow Control</b><br>00 <sub>B</sub> <b>NONE</b> No PAUSE<br>01 <sub>B</sub> <b>TX</b> Transmit PAUSE<br>10 <sub>B</sub> <b>RX</b> Receive PAUSE<br>11 <sub>B</sub> <b>TXRX</b> Both transmit and receive PAUSE   |
| DPX   | 3    | RO   | <b>Duplex mode at which the MII currently operates.</b><br>0 <sub>B</sub> <b>HDX</b> Half duplex<br>1 <sub>B</sub> <b>FDX</b> Full duplex   |
| EEE   | 2    | RO   | <b>Resolved Energy-Efficient Ethernet Mode</b><br>0 <sub>B</sub> <b>OFF</b> EEE is disabled after auto-negotiation resolution<br>1 <sub>B</sub> <b>ON</b> EEE is enabled after auto-negotiation resolution  |
| SPEED | 1:0  | RO   | <b>PHY Speed at which the MII Currently Operates.</b><br>00 <sub>B</sub> <b>TEN</b> 10 Mbps<br>01 <sub>B</sub> <b>FAST</b> 100 Mbps<br>10 <sub>B</sub> <b>GIGA</b> 1000 Mbps<br>11 <sub>B</sub> <b>FRE</b> FRE mode   |

**Interrupt Mask Register**

This register defines the mask for the Interrupt Status Register (ISTAT). Each masked interrupt is able to activate the MDINT pin to the management device. The information about the interrupt source can be extracted by reading the ISTAT register. A read operation on the ISTAT register simultaneously clears the interrupts, deactivating MDINT.

| IMASK                   |             | Offset          |              | Reset Value       |             |             |             |
|-------------------------|-------------|-----------------|--------------|-------------------|-------------|-------------|-------------|
| Interrupt Mask Register |             | 19 <sub>H</sub> |              | 0000 <sub>H</sub> |             |             |             |
| 15                      | 14          | 13              | 12           | 11                | 10          | 9           | 8           |
| <b>WOL</b>              | <b>MSRE</b> | <b>NPRX</b>     | <b>NPTX</b>  | <b>ANE</b>        | <b>ANC</b>  | <b>AMBF</b> | <b>LOR</b>  |
| rw                      | rw          | rw              | rw           | rw                | rw          | rw          | rw          |
| 7                       | 6           | 5               | 4            | 3                 | 2           | 1           | 0           |
| <b>RESL</b>             |             | <b>ADSC</b>     | <b>MDIPC</b> | <b>MDIXC</b>      | <b>DXMC</b> | <b>LSPC</b> | <b>LSTC</b> |
| ro                      |             | rw              | rw           | rw                | rw          | rw          | rw          |

| Field | Bits | Type | Description   |
|-------|------|------|---|
| WOL   | 15   | RW   | <b>Wake-On-LAN Event Mask</b><br>When active and masked in IMASK, the MDINT is activated upon detection of a valid Wake-On-LAN event.<br>0 <sub>B</sub> <b>INACTIVE</b> Interrupt is masked out<br>1 <sub>B</sub> <b>ACTIVE</b> Interrupt is activated                                |
| MSRE  | 14   | RW   | <b>Master/Slave Resolution Error Mask</b><br>When active, MDINT is activated upon detection of a master/slave resolution error during a 1000BASE-T auto-negotiation.<br>0 <sub>B</sub> <b>INACTIVE</b> Interrupt is masked out<br>1 <sub>B</sub> <b>ACTIVE</b> Interrupt is activated |
| NPRX  | 13   | RW   | <b>Next Page Received Mask</b><br>When active, MDINT is activated upon reception of a next page in STD.AN_NPRX.<br>0 <sub>B</sub> <b>INACTIVE</b> Interrupt is masked out<br>1 <sub>B</sub> <b>ACTIVE</b> Interrupt is activated  |
| NPTX  | 12   | RW   | <b>Next Page Transmitted Mask</b><br>When active, MDINT is activated upon transmission of the currently stored next page in STD.AN_NPTX.<br>0 <sub>B</sub> <b>INACTIVE</b> Interrupt is masked out<br>1 <sub>B</sub> <b>ACTIVE</b> Interrupt is activated                             |
| ANE   | 11   | RW   | <b>Auto-Negotiation Error Mask</b><br>When active, MDINT is activated upon detection of an auto-negotiation error.<br>0 <sub>B</sub> <b>INACTIVE</b> Interrupt is masked out<br>1 <sub>B</sub> <b>ACTIVE</b> Interrupt is activated   |



| Field | Bits | Type | Description  |
|-------|------|------|--|
| ANC   | 10   | RW   | <b>Auto-Negotiation Complete Mask</b><br>When active, MDINT is activated upon completion of the auto-negotiation process.<br>0 <sub>B</sub> <b>INACTIVE</b> Interrupt is masked out<br>1 <sub>B</sub> <b>ACTIVE</b> Interrupt is activated   |
| AMBF  | 9    | RW   | <b>MDIO Handling Fault</b><br>When active, MDINT is activated upon detection that the MDIO handling FIFO has overflowed and as such flushed and init by FW. This must indicate that one or more of the MDIO transactions before this event may be lost.<br>0 <sub>B</sub> <b>INACTIVE</b> Interrupt is masked out<br>1 <sub>B</sub> <b>ACTIVE</b> Interrupt is activated |
| LOR   | 8    | RW   | <b>SyncE Lost Of Reference</b><br>When active, MDINT is activated upon detection that the SyncE reference clock is lost.<br>0 <sub>B</sub> <b>INACTIVE</b> Interrupt is masked out<br>1 <sub>B</sub> <b>ACTIVE</b> Interrupt is activated  |
| RESL  | 7:6  | RO   | <b>Reserved</b><br>Write as zeros, ignore on read.   |
| ADSC  | 5    | RW   | <b>Link-Speed Auto-Downspeed Detect Mask</b><br>When active, MDINT is activated upon detection of a link speed auto-downspeed event.<br>0 <sub>B</sub> <b>INACTIVE</b> Interrupt is masked out<br>1 <sub>B</sub> <b>ACTIVE</b> Interrupt is activated  |
| MDIPC | 4    | RW   | <b>MDI Polarity Change Detect Mask</b><br>When active, MDINT is activated upon detection of an MDI polarity change event.<br>0 <sub>B</sub> <b>INACTIVE</b> Interrupt is masked out<br>1 <sub>B</sub> <b>ACTIVE</b> Interrupt is activated   |
| MDIXC | 3    | RW   | <b>MDIX Change Detect Mask</b><br>When active, MDINT is activated upon detection of an MDI/MDIX cross-over change event.<br>0 <sub>B</sub> <b>INACTIVE</b> Interrupt is masked out<br>1 <sub>B</sub> <b>ACTIVE</b> Interrupt is activated  |
| DXMC  | 2    | RW   | <b>Duplex Mode Change Mask</b><br>When active, MDINT is activated upon detection of full- or half-duplex change.<br>0 <sub>B</sub> <b>INACTIVE</b> Interrupt is masked out<br>1 <sub>B</sub> <b>ACTIVE</b> Interrupt is activated  |
| LSPC  | 1    | RW   | <b>Link Speed Change Mask</b><br>When active, MDINT is activated upon detection of link speed change.<br>0 <sub>B</sub> <b>INACTIVE</b> Interrupt is masked out<br>1 <sub>B</sub> <b>ACTIVE</b> Interrupt is activated   |
| LSTC  | 0    | RW   | <b>Link State Change Mask</b><br>When active, MDINT is activated upon detection of link status change.<br>0 <sub>B</sub> <b>INACTIVE</b> Interrupt is masked out<br>1 <sub>B</sub> <b>ACTIVE</b> Interrupt is activated  |

**Interrupt Status Register**

This register defines the Interrupt Status Register (ISTAT). Each masked interrupt (IMASK) is able to activate the MDINT pin to the management device. The information about the interrupt source can be extracted by reading the ISTA register. A read operation on the ISTAT register simultaneously clears the interrupts and this deactivates MDINT.

| ISTAT                     |             | Offset          |              | Reset Value       |             |             |             |
|---------------------------|-------------|-----------------|--------------|-------------------|-------------|-------------|-------------|
| Interrupt Status Register |             | 1A <sub>H</sub> |              | 0000 <sub>H</sub> |             |             |             |
| 15                        | 14          | 13              | 12           | 11                | 10          | 9           | 8           |
| <b>WOL</b>                | <b>MSRE</b> | <b>NPRX</b>     | <b>NPTX</b>  | <b>ANE</b>        | <b>ANC</b>  | <b>AMBF</b> | <b>LOR</b>  |
| rolh                      | rolh        | rolh            | rolh         | rolh              | rolh        | rw          | rolh        |
| 7                         | 6           | 5               | 4            | 3                 | 2           | 1           | 0           |
| <b>RESL</b>               |             | <b>ADSC</b>     | <b>MDIPC</b> | <b>MDIXC</b>      | <b>DXMC</b> | <b>LSPC</b> | <b>LSTC</b> |
| rolh                      |             | rolh            | rolh         | rolh              | rolh        | rolh        | rolh        |

| Field | Bits | Type | Description   |
|-------|------|------|---|
| WOL   | 15   | ROLH | <b>Wake-On-LAN Interrupt Status</b><br>When active and masked in IMASK, the MDINT is activated upon detection of a valid Wake-On-LAN event.<br>0 <sub>B</sub> <b>INACTIVE</b> Interrupt is masked out<br>1 <sub>B</sub> <b>ACTIVE</b> Interrupt is activated  |
| MSRE  | 14   | ROLH | <b>Master/Slave Resolution Error Interrupt Status</b><br>When active and masked in IMASK, the MDINT is activated upon detection of a master/slave resolution error during a 1000BASE-T auto-negotiation.<br>0 <sub>B</sub> <b>INACTIVE</b> Interrupt is masked out<br>1 <sub>B</sub> <b>ACTIVE</b> Interrupt is activated |
| NPRX  | 13   | ROLH | <b>Next Page Received Interrupt Status</b><br>When active and masked in IMASK, the MDINT is activated upon reception of a next page in STD.AN_NPRX.<br>0 <sub>B</sub> <b>INACTIVE</b> Interrupt is masked out<br>1 <sub>B</sub> <b>ACTIVE</b> Interrupt is activated  |
| NPTX  | 12   | ROLH | <b>Next Page Transmitted Interrupt Status</b><br>When active and masked in IMASK, the MDINT is activated upon transmission of the currently stored next page in STD.AN_NPTX.<br>0 <sub>B</sub> <b>INACTIVE</b> Interrupt is masked out<br>1 <sub>B</sub> <b>ACTIVE</b> Interrupt is activated                             |
| ANE   | 11   | ROLH | <b>Auto-Negotiation Error Interrupt Status</b><br>When active and masked in IMASK, the MDINT is activated upon detection of an auto-negotiation error.<br>0 <sub>B</sub> <b>INACTIVE</b> Interrupt is masked out<br>1 <sub>B</sub> <b>ACTIVE</b> Interrupt is activated   |

| Field | Bits | Type | Description  |
|-------|------|------|--|
| ANC   | 10   | ROLH | <b>Auto-Negotiation Complete Interrupt Status</b><br>When active and masked in IMASK, the MDINT is activated upon completion of the auto-negotiation process.<br>0 <sub>B</sub> <b>INACTIVE</b> Interrupt is masked out<br>1 <sub>B</sub> <b>ACTIVE</b> Interrupt is activated   |
| AMBF  | 9    | RW   | <b>MDIO Handling Fault</b><br>When active and masked in IMASK, MDINT is activated upon detection that the MDIO handling FIFO has overflowed and as such flushed and init by FW. This must indicate that one or more of the MDIO transactions before this event may be lost.<br>0 <sub>B</sub> <b>INACTIVE</b> Interrupt is masked out<br>1 <sub>B</sub> <b>ACTIVE</b> Interrupt is activated |
| LOR   | 8    | ROLH | <b>SyncE Lost Of Reference</b><br>When active and masked in IMASK, MDINT is activated upon detection that the SyncE reference clock is lost.<br>0 <sub>B</sub> <b>INACTIVE</b> Interrupt is masked out<br>1 <sub>B</sub> <b>ACTIVE</b> Interrupt is activated  |
| RESL  | 7:6  | ROLH | <b>Reserved</b><br>Write as zeros, ignore on read.   |
| ADSC  | 5    | ROLH | <b>Link Speed Auto-Downspeed Detect Interrupt Status</b><br>When active and masked in IMASK, the MDINT is activated upon detection of a link speed auto-downspeed event.<br>0 <sub>B</sub> <b>INACTIVE</b> Interrupt is masked out<br>1 <sub>B</sub> <b>ACTIVE</b> Interrupt is activated  |
| MDIPC | 4    | ROLH | <b>MDI Polarity Change Detect Interrupt Status</b><br>When active and masked in IMASK, the MDINT is activated upon detection of an MDI polarity change event.<br>0 <sub>B</sub> <b>INACTIVE</b> Interrupt is masked out<br>1 <sub>B</sub> <b>ACTIVE</b> Interrupt is activated   |
| MDIXC | 3    | ROLH | <b>MDIX Change Detect Interrupt Status</b><br>When active and masked in IMASK, the MDINT is activated upon detection of an MDI/MDIX cross-over change event.<br>0 <sub>B</sub> <b>INACTIVE</b> Interrupt is masked out<br>1 <sub>B</sub> <b>ACTIVE</b> Interrupt is activated  |
| DXMC  | 2    | ROLH | <b>Duplex Mode Change Interrupt Status</b><br>When active and masked in IMASK, the MDINT is activated upon detection of a full or half-duplex change.<br>0 <sub>B</sub> <b>INACTIVE</b> Interrupt is masked out<br>1 <sub>B</sub> <b>ACTIVE</b> Interrupt is activated   |
| LSPC  | 1    | ROLH | <b>Link Speed Change Interrupt Status</b><br>When active and masked in IMASK, the MDINT is activated upon detection of link speed change.<br>0 <sub>B</sub> <b>INACTIVE</b> Interrupt is masked out<br>1 <sub>B</sub> <b>ACTIVE</b> Interrupt is activated   |

| Field | Bits | Type | Description   |
|-------|------|------|---|
| LSTC  | 0    | ROLH | <b>Link State Change Interrupt Status</b><br>When active and masked in IMASK, the MDINT is activated upon detection of link status change.<br>0 <sub>B</sub> <b>INACTIVE</b> Interrupt is masked out<br>1 <sub>B</sub> <b>ACTIVE</b> Interrupt is activated |

**LED Control Register**

This register contains control bits to allow for direct access to the LEDs. A directly controlled LED must disable the integrated LED function as specified by the more sophisticated LED control registers in page LED.

| LED                  | Offset          | Reset Value       |               |               |               |
|----------------------|-----------------|-------------------|---------------|---------------|---------------|
| LED Control Register | 1B <sub>H</sub> | 0F00 <sub>H</sub> |               |               |               |
| 15                   | 12              | 11                | 10            | 9             | 8             |
|                      | <b>RESH</b>     | <b>LED3EN</b>     | <b>LED2EN</b> | <b>LED1EN</b> | <b>LED0EN</b> |
|                      | ro              | rw                | rw            | rw            | rw            |
| 7                    | 4               | 3                 | 2             | 1             | 0             |
|                      | <b>RESL</b>     | <b>LED3DA</b>     | <b>LED2DA</b> | <b>LED1DA</b> | <b>LED0DA</b> |
|                      | ro              | rw                | rw            | rw            | rw            |

| Field  | Bits  | Type | Description   |
|--------|-------|------|---|
| RESH   | 15:12 | RO   | <b>Reserved</b><br>Write as zero, ignored on read.  |
| LED3EN | 11    | RW   | <b>Enable the integrated function of LED3</b><br>Write a logic 0 to this bit to disable the pre-configured integrated function for this LED. The LED remains off unless directly accessed via LED3DA.<br>0 <sub>B</sub> <b>DISABLE</b> Disables the integrated LED function<br>1 <sub>B</sub> <b>ENABLE</b> Enables the integrated LED function |
| LED2EN | 10    | RW   | <b>Enable the integrated function of LED2</b><br>Write a logic 0 to this bit to disable the pre-configured integrated function for this LED. The LED remains off unless directly accessed via LED2DA.<br>0 <sub>B</sub> <b>DISABLE</b> Disables the integrated LED function<br>1 <sub>B</sub> <b>ENABLE</b> Enables the integrated LED function |
| LED1EN | 9     | RW   | <b>Enable the Integrated Function of LED1</b><br>Write a logic 0 to this bit to disable the pre-configured integrated function for this LED. The LED remains off unless directly accessed via LED1DA.<br>0 <sub>B</sub> <b>DISABLE</b> Disables the integrated LED function<br>1 <sub>B</sub> <b>ENABLE</b> Enables the integrated LED function |
| LED0EN | 8     | RW   | <b>Enable the Integrated Function of LED0</b><br>Write a logic 0 to this bit to disable the pre-configured integrated function for this LED. The LED remains off unless directly accessed via LED0DA.<br>0 <sub>B</sub> <b>DISABLE</b> Disables the integrated LED function<br>1 <sub>B</sub> <b>ENABLE</b> Enables the integrated LED function |

| Field  | Bits | Type | Description   |
|--------|------|------|---|
| RESL   | 7:4  | RO   | <b>Reserved</b><br>Write as zero, ignored on read.  |
| LED3DA | 3    | RW   | <b>Direct Access to LED3</b><br>Write a logic 1 to this bit to illuminate the LED.<br>LED3EN must be set to logic zero.<br>0 <sub>B</sub> <b>OFF</b> Switch off the LED<br>1 <sub>B</sub> <b>ON</b> Switch on the LED |
| LED2DA | 2    | RW   | <b>Direct Access to LED2</b><br>Write a logic 1 to this bit to illuminate the LED.<br>LED2EN must be set to logic zero.<br>0 <sub>B</sub> <b>OFF</b> Switch off the LED<br>1 <sub>B</sub> <b>ON</b> Switch on the LED |
| LED1DA | 1    | RW   | <b>Direct Access to LED1</b><br>Write a logic 1 to this bit to illuminate the LED.<br>LED1EN must be set to logic zero.<br>0 <sub>B</sub> <b>OFF</b> Switch off the LED<br>1 <sub>B</sub> <b>ON</b> Switch on the LED |
| LED0DA | 0    | RW   | <b>Direct Access to LED0</b><br>Write a logic 1 to this bit to illuminate the LED.<br>LED0EN must be set to logic zero.<br>0 <sub>B</sub> <b>OFF</b> Switch off the LED<br>1 <sub>B</sub> <b>ON</b> Switch on the LED |

**Test-Packet Generator Control**

This register controls the operation of the integrated Test-Packet Generator (TPG). This module is only used for testing purposes.

| TPGCTRL   | Offset                | Reset Value             |                 |             |              |             |   |   |              |  |             |                 |             |  |             |  |    |  |    |    |    |  |    |  |   |   |   |   |   |   |   |              |             |  |             |  |              |           |    |    |  |    |  |    |    |  |  |
|---|-----------------------|-------------------------|-----------------|-------------|--------------|-------------|---|---|--------------|--|-------------|-----------------|-------------|--|-------------|--|----|--|----|----|----|--|----|--|---|---|---|---|---|---|---|--------------|-------------|--|-------------|--|--------------|-----------|----|----|--|----|--|----|----|--|--|
| <b>Test-Packet Generator Control</b>  | <b>1C<sub>H</sub></b> | <b>0000<sub>H</sub></b> |                 |             |              |             |   |   |              |  |             |                 |             |  |             |  |    |  |    |    |    |  |    |  |   |   |   |   |   |   |   |              |             |  |             |  |              |           |    |    |  |    |  |    |    |  |  |
| <table border="1" style="width:100%; text-align:center;"> <tr> <td>15</td><td>14</td><td>13</td><td>12</td><td>11</td><td>10</td><td>9</td><td>8</td> </tr> <tr> <td colspan="2"><b>CHSEL</b></td> <td><b>MODE</b></td> <td><b>BURST4EN</b></td> <td colspan="2"><b>IPGL</b></td> <td colspan="2"><b>TYPE</b></td> </tr> <tr> <td colspan="2">rw</td> <td>rw</td> <td>rw</td> <td colspan="2">rw</td> <td colspan="2">rw</td> </tr> <tr> <td>7</td><td>6</td><td>4</td><td>3</td><td>2</td><td>1</td><td>0</td> </tr> <tr> <td><b>RESL1</b></td> <td colspan="2"><b>SIZE</b></td> <td colspan="2"><b>MOPT</b></td> <td><b>START</b></td> <td><b>EN</b></td> </tr> <tr> <td>ro</td> <td colspan="2">rw</td> <td colspan="2">rw</td> <td>rw</td> <td>rw</td> </tr> </table> | 15                    | 14                      | 13              | 12          | 11           | 10          | 9 | 8 | <b>CHSEL</b> |  | <b>MODE</b> | <b>BURST4EN</b> | <b>IPGL</b> |  | <b>TYPE</b> |  | rw |  | rw | rw | rw |  | rw |  | 7 | 6 | 4 | 3 | 2 | 1 | 0 | <b>RESL1</b> | <b>SIZE</b> |  | <b>MOPT</b> |  | <b>START</b> | <b>EN</b> | ro | rw |  | rw |  | rw | rw |  |  |
| 15  | 14                    | 13                      | 12              | 11          | 10           | 9           | 8 |   |              |  |             |                 |             |  |             |  |    |  |    |    |    |  |    |  |   |   |   |   |   |   |   |              |             |  |             |  |              |           |    |    |  |    |  |    |    |  |  |
| <b>CHSEL</b>  |                       | <b>MODE</b>             | <b>BURST4EN</b> | <b>IPGL</b> |              | <b>TYPE</b> |   |   |              |  |             |                 |             |  |             |  |    |  |    |    |    |  |    |  |   |   |   |   |   |   |   |              |             |  |             |  |              |           |    |    |  |    |  |    |    |  |  |
| rw  |                       | rw                      | rw              | rw          |              | rw          |   |   |              |  |             |                 |             |  |             |  |    |  |    |    |    |  |    |  |   |   |   |   |   |   |   |              |             |  |             |  |              |           |    |    |  |    |  |    |    |  |  |
| 7   | 6                     | 4                       | 3               | 2           | 1            | 0           |   |   |              |  |             |                 |             |  |             |  |    |  |    |    |    |  |    |  |   |   |   |   |   |   |   |              |             |  |             |  |              |           |    |    |  |    |  |    |    |  |  |
| <b>RESL1</b>  | <b>SIZE</b>           |                         | <b>MOPT</b>     |             | <b>START</b> | <b>EN</b>   |   |   |              |  |             |                 |             |  |             |  |    |  |    |    |    |  |    |  |   |   |   |   |   |   |   |              |             |  |             |  |              |           |    |    |  |    |  |    |    |  |  |
| ro  | rw                    |                         | rw              |             | rw           | rw          |   |   |              |  |             |                 |             |  |             |  |    |  |    |    |    |  |    |  |   |   |   |   |   |   |   |              |             |  |             |  |              |           |    |    |  |    |  |    |    |  |  |

| Field    | Bits  | Type | Description  |
|----------|-------|------|--|
| CHSEL    | 15:14 | RW   | <b>Channel Selection</b><br>There are 4 channels in the IP which can be selected for debug data dumping. This field is not used in case BURST4EN=1 && MOPT=1 (auto-channel burst).<br>00 <sub>B</sub> <b>CHA</b> Channel A is selected<br>01 <sub>B</sub> <b>CHB</b> Channel B is selected<br>10 <sub>B</sub> <b>CHC</b> Channel C is selected<br>11 <sub>B</sub> <b>CHD</b> Channel D is selected   |
| MODE     | 13    | RW   | <b>TPG Mode</b><br>Configures the packet generation mode .<br>0 <sub>B</sub> <b>CONTINUOUS</b> Send packets continuously<br>1 <sub>B</sub> <b>SINGLE</b> Send a single packet. Also used to send a single burst of 4 packets in debug dumping when selected.   |
| BURST4EN | 12    | RW   | <b>Burst of 4 Packets Enable</b><br>When Enabled, this indicates to the packet generator to auto-select based on MOPT the debug data configuration per packet in the burst of 4.<br>When MOPT=0, then the packets are generated capturing for the selected ASP channel, the polyphases 0,1,2,3 respectively.<br>When MOPT=1, then the packets are generated capturing for the selected DVC option, the channels A,B,C,D respectively.<br>This leads to a burst of 4 packets when MODE=SINGLE. In case MODE=1(continuous), then we get packets where every group of 4 packets are generated according to the MOPT selection.<br>0 <sub>B</sub> <b>DISABLE</b> Disable<br>1 <sub>B</sub> <b>ENABLE</b> Enable burst of 4 packet generation |
| IPGL     | 11:10 | RW   | <b>Inter-Packet Gap Length</b><br>Configures the length of the inter-packet gap in bit times.<br>00 <sub>B</sub> <b>BT48</b> Length is 48 bit times<br>01 <sub>B</sub> <b>BT96</b> Length is 96 bit times<br>10 <sub>B</sub> <b>BT960</b> Length is 960 bit times<br>11 <sub>B</sub> <b>BT9600</b> Length is 9600 bit times  |
| TYPE     | 9:8   | RW   | <b>Packet Data Type</b><br>Configures the packet data type to be either predefined, byte increment or random. When predefined, the content of the register TPGDATA is used repetitively.<br>00 <sub>B</sub> <b>RANDOM</b> Use random data as the packet content<br>01 <sub>B</sub> <b>BYTEINC</b> Use byte increment as the packet content<br>10 <sub>B</sub> <b>PREDEF</b> Use pre-defined content of the register TPGDATA<br>11 <sub>B</sub> <b>DBGDATA</b> Use Dbg data as packet content. Additional Configuration is taken from TPGDATA   |
| RESL1    | 7     | RO   | <b>Reserved</b><br>Write as zero, ignore on read.  |

| Field | Bits | Type | Description  |
|-------|------|------|--|
| SIZE  | 6:4  | RW   | <p><b>Packet Size</b><br/>Configures the size of the generated Ethernet packets in bytes. The size includes DA, SA, length/type, payload and FCS.</p> <p>000<sub>B</sub> <b>L64</b> Packet length is 64 bytes.<br/>           001<sub>B</sub> <b>L2048</b> Packet length is 2048 bytes (jumbo frames).<br/>           010<sub>B</sub> <b>L256</b> Packet length is 256 bytes.<br/>           011<sub>B</sub> <b>L4096</b> Packet length is 4096 bytes (jumbo frames).<br/>           100<sub>B</sub> <b>L1024</b> Packet length is 1024 bytes.<br/>           101<sub>B</sub> <b>L1518</b> Packet length is 1518 bytes.<br/>           110<sub>B</sub> <b>L9000</b> Packet length is 9000 bytes (jumbo frames).<br/>           111<sub>B</sub> <b>RANDOM</b> Packet length is randomized between upper sizes without jumbo frames.</p> |
| MOPT  | 3:2  | RW   | <p><b>Mux Option</b><br/>Additional Mux Selection Options depending on the value of DVC in TPGDATA[3:0].</p> <p>00<sub>B</sub> <b>MOPT0</b> BURST4EN=1: auto-polyphase selected, BURST4EN=0 &amp;&amp; DVC=0b1001: DBG SYNC Data Gen, otherwise sub-DVC-mode selection<br/>           01<sub>B</sub> <b>MOPT1</b> BURST4EN=1: auto-channel selected, BURST4EN=0 &amp;&amp; DVC=0b1001: DBG Trace Data, otherwise sub-DVC-mode selection<br/>           10<sub>B</sub> <b>MOPT2</b> sub-DVC-mode selection<br/>           11<sub>B</sub> <b>MOPT3</b> sub-DVC-mode selection</p>  |
| START | 1    | RW   | <p><b>Start or Stop TPG Data Generation.</b><br/>Starts the TPG data generation. Depending on the MODE, the TPG sends only 1 single packet or chunks of 10,000 packets until stopped.</p> <p>0<sub>B</sub> <b>STOP</b> Stops the TPG data generation<br/>           1<sub>B</sub> <b>START</b> Starts the TPG data generation</p>  |
| EN    | 0    | RW   | <p><b>Enable the TPG</b><br/>Enables the TPG for data generation.</p> <p>0<sub>B</sub> <b>DISABLE</b> Disables the TPG<br/>           1<sub>B</sub> <b>ENABLE</b> Enables the TPG</p>  |

**Test-Packet Generator Data**

Specifies the payload data to be used when sending a non-random data packet. All payload data bytes are sent with this value.

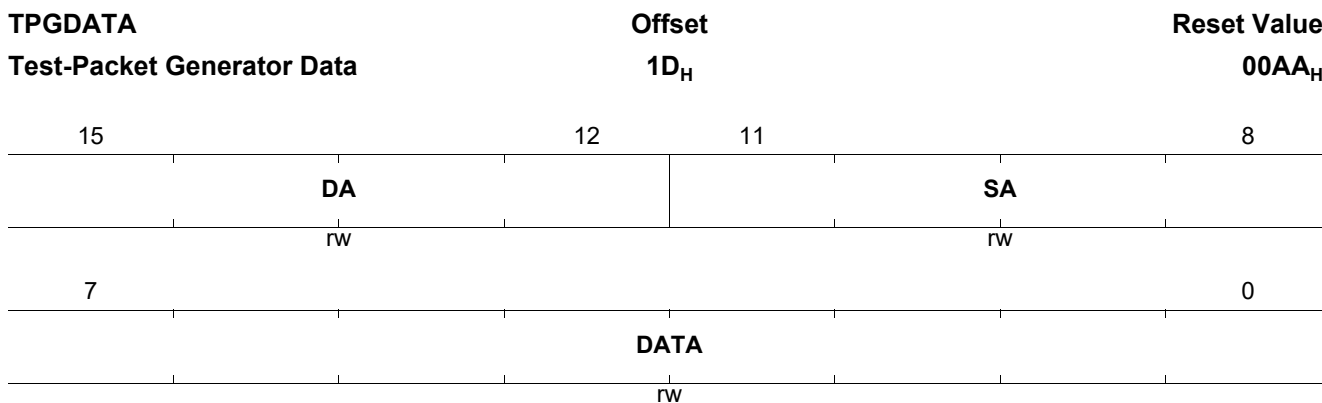

| Field | Bits  | Type | Description  |
|-------|-------|------|--|
| DA    | 15:12 | RW   | <b>Destination Address</b><br>Configures the destination address nibble. The Source Address builds up to 00-03-19-FF-FF-F[DA].   |
| SA    | 11:8  | RW   | <b>Source Address</b><br>Configures the source address nibble. The source address builds up to 00-03-19-FF-FF-F[SA].   |
| DATA  | 7:0   | RW   | <b>Data Byte to be Transmitted</b><br>This is the content of the payload bytes in the frame in case it is selected to send constant data. When it is selected to send debug data, this byte has additional configuration as seen in the constants listed here. The bit masks are listed here. Refer to the related section for more details on the configuration.<br>00001111 <sub>B</sub> <b>DVC</b> Select the debug data to be dump<br>00010000 <sub>B</sub> <b>RESERVED</b> Reserved<br>01100000 <sub>B</sub> <b>PREC2</b> For reduce precision, select the options with bits [6:5]<br>10000000 <sub>B</sub> <b>PREC</b> select whether to take full precision('1') of reduce precision '0' at bit 7 |



**Firmware Version Register**

This register contains the version of the PHY firmware.

| FWV                       |    | Offset          | Reset Value       |
|---------------------------|----|-----------------|-------------------|
| Firmware Version Register |    | 1E <sub>H</sub> | 8304 <sub>H</sub> |
| 15                        | 14 |                 | 8                 |
| <b>REL</b>                |    | <b>MAJOR</b>    |                   |
| ro                        |    | ro              |                   |
| 7                         |    |                 | 0                 |
|                           |    | <b>MINOR</b>    |                   |
|                           |    | ro              |                   |

| Field | Bits | Type | Description  |
|-------|------|------|--|
| REL   | 15   | RO   | <b>Release Indication</b><br>This parameter indicates either a test or a release version.<br>0 <sub>B</sub> <b>TEST</b> Indicates a test version<br>1 <sub>B</sub> <b>RELEASE</b> Indicates a released version |
| MAJOR | 14:8 | RO   | <b>Major Version Number</b><br>Specifies the main version release number of the firmware.  |
| MINOR | 7:0  | RO   | <b>Minor Version Number</b><br>Specifies the sub-version release number of the firmware.   |

**Reserved**

Reserved.

| RES1F    |  | Offset          | Reset Value       |
|----------|--|-----------------|-------------------|
| Reserved |  | 1F <sub>H</sub> | 0000 <sub>H</sub> |
| 15       |  |                 | 8                 |
|          |  | <b>RES</b>      |                   |
|          |  | ro              |                   |
| 7        |  |                 | 0                 |
|          |  | <b>RES</b>      |                   |
|          |  | ro              |                   |

| Field | Bits | Type | Description  |
|-------|------|------|--|
| RES   | 15:0 | RO   | <b>Reserved</b><br>Write as zero, ignored on read. |

#### 4.4 PHY MMD Registers

This section defines all the registers required to operate the MMD\_REGISTERS module.<sup>1)</sup>

**Table 62 Registers Address Space**

| Module        | Base Address        | End Address          | Note |
|---------------|---------------------|----------------------|------|
| MMD_REGISTERS | 000000 <sub>H</sub> | 1FFFFFF <sub>H</sub> |      |

**Table 63 Registers Overview**

| Register Short Name  | Register Long Name                                       | Offset Address       | Reset Value       |
|--|--|----------------------|-------------------|
| <b>PHY MMD Registers, PMAPMD: Standard PMAPMD Registers for MMD=0x01</b>         |  |                      |                   |
| <b>TIMESYNC_CAP</b>  | PMAPMD TimeSync Capability Indication                    | 01.1800 <sub>H</sub> | 0000 <sub>H</sub> |
| <b>PHY MMD Registers, EEE: Standard EEE Registers for MMD=0x03</b>               |  |                      |                   |
| <b>EEE_CTRL1</b>   | EEE Control Register 1                                   | 03.0000 <sub>H</sub> | 0000 <sub>H</sub> |
| <b>EEE_STAT1</b>   | EEE Status Register 1                                    | 03.0001 <sub>H</sub> | 0000 <sub>H</sub> |
| <b>EEE_CAP</b>   | EEE Capability Register                                  | 03.0014 <sub>H</sub> | 0006 <sub>H</sub> |
| <b>EEE_WAKERR</b>  | EEE Status Register 1                                    | 03.0016 <sub>H</sub> | 0000 <sub>H</sub> |
| <b>PHY MMD Registers, ANEG: Standard Auto-Negotiation Registers for MMD=0x07</b> |  |                      |                   |
| <b>EEE_AN_ADV</b>  | EEE Auto-Negotiation Advertisement Register              | 07.003C <sub>H</sub> | 0000 <sub>H</sub> |
| <b>EEE_AN_LPADV</b>  | EEE Auto-Negotiation Link-Partner Advertisement Register | 07.003D <sub>H</sub> | 0000 <sub>H</sub> |
| <b>PHY MMD Registers, INTERNAL: Internal Address Space (MMD=0x1F)</b>            |  |                      |                   |
| <b>LEDCH</b>   | LED Configuration  | 1F.01E0 <sub>H</sub> | 00C5 <sub>H</sub> |
| <b>LEDCL</b>   | LED Configuration  | 1F.01E1 <sub>H</sub> | 0067 <sub>H</sub> |
| <b>LED0H</b>   | Configuration for LED Pin 0                              | 1F.01E2 <sub>H</sub> | 0070 <sub>H</sub> |
| <b>LED1H</b>   | Configuration for LED Pin 1                              | 1F.01E4 <sub>H</sub> | 0020 <sub>H</sub> |
| <b>LED2H</b>   | Configuration for LED Pin 2                              | 1F.01E6 <sub>H</sub> | 0040 <sub>H</sub> |
| <b>LED3H</b>   | Configuration for LED Pin 3                              | 1F.01E8 <sub>H</sub> | 0040 <sub>H</sub> |
| <b>LED0L</b>   | Configuration for LED Pin 0                              | 1F.01E3 <sub>H</sub> | 0003 <sub>H</sub> |
| <b>LED1L</b>   | Configuration for LED Pin 1                              | 1F.01E5 <sub>H</sub> | 0000 <sub>H</sub> |
| <b>LED2L</b>   | Configuration for LED Pin 2                              | 1F.01E7 <sub>H</sub> | 0000 <sub>H</sub> |
| <b>LED3L</b>   | Configuration for LED Pin 3                              | 1F.01E9 <sub>H</sub> | 0020 <sub>H</sub> |
| <b>EEE_RXERR_LINK_FA_IL_H</b>  | High Byte of the EEE Link-Fail Counter                   | 1F.01EA <sub>H</sub> | 0000 <sub>H</sub> |
| <b>EEE_RXERR_LINK_FA_IL_L</b>  | Low Byte of the EEE Link-Fail Counter                    | 1F.01EB <sub>H</sub> | 0000 <sub>H</sub> |
| <b>WOLCTRL</b>   | Wake-On-LAN Control Register                             | 1F.0781 <sub>H</sub> | 0000 <sub>H</sub> |
| <b>WOLAD0</b>  | Wake-On-LAN Address Byte 0                               | 1F.0783 <sub>H</sub> | 0000 <sub>H</sub> |
| <b>WOLAD1</b>  | Wake-On-LAN Address Byte 1                               | 1F.0784 <sub>H</sub> | 0000 <sub>H</sub> |
| <b>WOLAD2</b>  | Wake-On-LAN Address Byte 2                               | 1F.0785 <sub>H</sub> | 0000 <sub>H</sub> |

1) Generated by REFIGE v1.4 - Beta Release XIV

**Table 63 Registers Overview (cont'd)**

| Register Short Name | Register Long Name                     | Offset Address       | Reset Value       |
|---------------------|--|----------------------|-------------------|
| <b>WOLAD3</b>       | Wake-On-LAN Address Byte 3             | 1F.0786 <sub>H</sub> | 0000 <sub>H</sub> |
| <b>WOLAD4</b>       | Wake-On-LAN Address Byte 4             | 1F.0787 <sub>H</sub> | 0000 <sub>H</sub> |
| <b>WOLAD5</b>       | Wake-On-LAN Address Byte 5             | 1F.0788 <sub>H</sub> | 0000 <sub>H</sub> |
| <b>WOLPW0</b>       | Wake-On-LAN SecureON Password Byte 0   | 1F.0789 <sub>H</sub> | 0000 <sub>H</sub> |
| <b>WOLPW1</b>       | Wake-On-LAN SecureON Password Byte 1   | 1F.078A <sub>H</sub> | 0000 <sub>H</sub> |
| <b>WOLPW2</b>       | Wake-On-LAN SecureON Password Byte 2   | 1F.078B <sub>H</sub> | 0000 <sub>H</sub> |
| <b>WOLPW3</b>       | Wake-On-LAN SecureON Password Byte 3   | 1F.078C <sub>H</sub> | 0000 <sub>H</sub> |
| <b>WOLPW4</b>       | Wake-On-LAN SecureON Password Byte 4   | 1F.078D <sub>H</sub> | 0000 <sub>H</sub> |
| <b>WOLPW5</b>       | Wake-On-LAN SecureON Password Byte 5   | 1F.078E <sub>H</sub> | 0000 <sub>H</sub> |
| <b>PD_CTL</b>       | Configuration for Synchronous Ethernet | 1F.07FE <sub>H</sub> | 0000 <sub>H</sub> |

The register is addressed wordwise.

**Table 64 Register Access Types**

| Mode                               | Symbol | Internal Hardware Configuration |          |             |
|------------------------------------|--------|---------------------------------|----------|-------------|
|                                    |        | Type                            | Behavior | Arbitration |
| Status Register, Latch-High        | ROLH   | WOR                             | AUTO_PDI | CLROR       |
| Status Register, Latch-Low         | ROLL   | WOR                             | AUTO_PDI | CLROR       |
| Status Register, Self-Clearing     | ROSC   | WOR                             | AUTO_PDI | CLROR       |
| Read-Write Register                | RW     | RWR                             | AUTO_PDI | -           |
| Read-Write Register, Self-Clearing | RWSC   | RWR                             | AUTO_PDI | CLROR       |
| Status Register                    | RO     | WOR                             | AUTO_PDI | -           |

#### 4.4.1 PMAPMD: Standard PMAPMD Registers for MMD=0x01

This section describe the registers for support of IEEE 802.3BF indication for TimeSync (a.k.a SyncT interface in this IP).

##### PMAPMD TimeSync Capability Indication

PMAPMD TimeSync Capability indication Register. This IP does not support providing data path delay information. It is provided to enhance compatibility

| TIMESYNC_CAP                          | Offset               | Reset Value       |
|---------------------------------------|----------------------|-------------------|
| PMAPMD TimeSync Capability Indication | 01.1800 <sub>H</sub> | 0000 <sub>H</sub> |
| 15                                    |                      | 8                 |
| Res                                   |                      |                   |
| 7                                     | 2                    | 1 0               |
|                                       | Res                  | TXDEL RXDEL       |
|                                       |                      | ro ro             |

| Field | Bits | Type | Description  |
|-------|------|------|--|
| TXDEL | 1    | RO   | <b>Transmit Data Path Delay Information</b><br>PHY indicates whether it is capable of providing the minimum and maximum data path delay information.<br>0 <sub>B</sub> <b>NONE</b> PHY do not have this capability<br>1 <sub>B</sub> <b>CAPABLE</b> min and max TX data path delay available |
| RXDEL | 0    | RO   | <b>Receive Data Path Delay Information</b><br>PHY indicates whether it is capable of providing the minimum and maximum data path delay information.<br>0 <sub>B</sub> <b>NONE</b> PHY do not have this capability<br>1 <sub>B</sub> <b>CAPABLE</b> min and max RX data path delay available  |

#### 4.4.2 EEE: Standard EEE Registers for MMD=0x03

This section describes the EEE registers for MMD device 0x03.

##### EEE Control Register 1

EEE Control Register 1.

| EEE_CTRL1<br>EEE Control Register 1 | Offset<br>03.0000 <sub>H</sub> | Reset Value<br>0000 <sub>H</sub> |
|-------------------------------------|--------------------------------|----------------------------------|
| 15                                  | 11                             | 10                               |
| Res                                 | RXCKST                         | Res                              |
|                                     | rw                             |                                  |
| 7                                   |                                | 0                                |
| Res                                 |                                |                                  |

| Field  | Bits | Type | Description   |
|--------|------|------|---|
| RXCKST | 10   | RW   | <b>Receive Clock Stoppable</b><br>The MAC can set this bit to active to allow the PHY to stop the clocking during the LPI_MODE.<br>0 <sub>B</sub> <b>DISABLE</b> The PHY must not stop the xMII clock during LPI_MODE<br>1 <sub>B</sub> <b>ENABLE</b> The PHY can stop the xMII clock during LPI_MODE |

##### EEE Status Register 1

EEE Status Register 1.

| EEE_STAT1<br>EEE Status Register 1 | Offset<br>03.0001 <sub>H</sub> | Reset Value<br>0000 <sub>H</sub> |
|------------------------------------|--------------------------------|----------------------------------|
| 15                                 | 12                             | 11                               |
| Res                                | TXLPI_RCVD                     | RXLPI_RCVD                       |
|                                    | rolh                           | rolh                             |
| 7                                  | 6                              | 5                                |
| Res                                | TXCKST                         | Res                              |
|                                    | ro                             |                                  |
| 8                                  |                                | 0                                |
| TXLPI_IND                          |                                | RXLPI_IND                        |
|                                    |                                | ro                               |

| Field      | Bits | Type | Description   |
|------------|------|------|---|
| TXLPI_RCVD | 11   | ROLH | <b>TXLPI Received</b><br>0 <sub>B</sub> <b>INACTIVE</b> LPI has not been received<br>1 <sub>B</sub> <b>ACTIVE</b> LPI has been received |

**Registers**

| Field      | Bits | Type | Description   |
|------------|------|------|---|
| RXLPI_RCVD | 10   | ROLH | <b>RXLPI Received</b><br>0 <sub>B</sub> <b>INACTIVE</b> LPI has not been received<br>1 <sub>B</sub> <b>ACTIVE</b> LPI has been received   |
| TXLPI_IND  | 9    | RO   | <b>TXLPI Indication</b><br>0 <sub>B</sub> <b>INACTIVE</b> LPI is currently inactive<br>1 <sub>B</sub> <b>ACTIVE</b> LPI is currently active   |
| RXLPI_IND  | 8    | RO   | <b>RXLPI Indication</b><br>0 <sub>B</sub> <b>INACTIVE</b> LPI is currently inactive<br>1 <sub>B</sub> <b>ACTIVE</b> LPI is currently active   |
| TXCKST     | 6    | RO   | <b>Transmit Clock Stoppable</b><br>Indicate whether PHY is able to accept a stopped transmit clock during LPI_MODE. MAC may choose to stop the clocking during LPI_MODE when this bit is set to active.<br>0 <sub>B</sub> <b>DISABLE</b> The PHY is not able to accept stopped transmit clocks (default)<br>1 <sub>B</sub> <b>ENABLE</b> The PHY is able to accept a stopped transmit clock during LPI_MODE |

**EEE Capability Register**

This register is used to indicate the capability of the PCS to support EEE functions for each PHY type.

| EEE_CAP                        | Offset                     |                 |                 |           |            |            |     | Reset Value             |
|--------------------------------|----------------------------|-----------------|-----------------|-----------|------------|------------|-----|-------------------------|
| <b>EEE Capability Register</b> | <b>03.0014<sub>H</sub></b> |                 |                 |           |            |            |     | <b>0006<sub>H</sub></b> |
| 15                             |                            |                 |                 |           |            |            |     | 8                       |
| Res                            |                            |                 |                 |           |            |            |     |                         |
| 7                              | 6                          | 5               | 4               | 3         | 2          | 1          | 0   |                         |
| Res                            | EEE_10GBKR                 | EEE_10GBKX<br>4 | EEE_1000BK<br>X | EEE_10GBT | EEE_1000BT | EEE_100BTX | Res |                         |
|                                | ro                         | ro              | ro              | ro        | ro         | ro         |     |                         |

| Field           | Bits | Type | Description   |
|-----------------|------|------|---|
| EEE_10GBKR      | 6    | RO   | <b>Support of 10GBASE-KR EEE</b><br>0 <sub>B</sub> <b>DISABLED</b> This PHY mode is not supported for EEE<br>1 <sub>B</sub> <b>ENABLE</b> This PHY mode is supported for EEE  |
| EEE_10GBKX<br>4 | 5    | RO   | <b>Support of 10GBASE-KX4 EEE</b><br>0 <sub>B</sub> <b>DISABLED</b> This PHY mode is not supported for EEE<br>1 <sub>B</sub> <b>ENABLE</b> This PHY mode is supported for EEE |
| EEE_1000BK<br>X | 4    | RO   | <b>Support of 1000BASE-KX EEE</b><br>0 <sub>B</sub> <b>DISABLED</b> This PHY mode is not supported for EEE<br>1 <sub>B</sub> <b>ENABLE</b> This PHY mode is supported for EEE |

**Registers**

| Field      | Bits | Type | Description  |
|------------|------|------|--|
| EEE_10GBT  | 3    | RO   | <b>Support of 10GBASE-T EEE</b><br>0 <sub>B</sub> <b>DISABLED</b> This PHY mode is not supported for EEE<br>1 <sub>B</sub> <b>ENABLE</b> This PHY mode is supported for EEE  |
| EEE_1000BT | 2    | RO   | <b>Support of 1000BASE-T EEE</b><br>0 <sub>B</sub> <b>DISABLED</b> This PHY mode is not supported for EEE<br>1 <sub>B</sub> <b>ENABLE</b> This PHY mode is supported for EEE |
| EEE_100BTX | 1    | RO   | <b>Support of 100BASE-TX EEE</b><br>0 <sub>B</sub> <b>DISABLED</b> This PHY mode is not supported for EEE<br>1 <sub>B</sub> <b>ENABLE</b> This PHY mode is supported for EEE |

**EEE Status Register 1**

Not Specified

| EEE_WAKERR            | Offset               | Reset Value       |
|-----------------------|----------------------|-------------------|
| EEE Status Register 1 | 03.0016 <sub>H</sub> | 0000 <sub>H</sub> |
| 15                    |                      | 8                 |
|                       | ERRCNT               |                   |
|                       | ro                   |                   |
| 7                     |                      | 0                 |
|                       | ERRCNT               |                   |
|                       | ro                   |                   |

| Field  | Bits | Type | Description  |
|--------|------|------|--|
| ERRCNT | 15:0 | RO   | <b>EEE Wake Error Counter</b><br>This register is used by PHY types that support EEE to count wake time faults where the PHY fails to complete its normal wake sequence within the time required for the specific PHY type. The definition of the fault event to be counted is defined for each PHY and may occur during a refresh or a wake-up as defined by the PHY. This 16-bit counter is reset to all zeroes when the EEE wake error counter is read by the management function or upon execution of the PCS reset. It is held at all ones in case of overflow. |

### 4.4.3 ANEG: Standard Auto-Negotiation Registers for MMD=0x07

This register file contains the auto-negotiation registers for MMD device 0x07 (only supporting EEE specifics).

#### EEE Auto-Negotiation Advertisement Register

This register defines the EEE advertisement sent in the unformatted next page following an EEE technology message code as defined in 28C.12. The 11 bits (7.60.10 to 7.60.0) in the EEE advertisement register correspond to the bits in the unformatted next page. For PHYs that negotiate extended next-page support, the 11 bits (7.60.10 to 7.60.0) in the EEE advertisement register correspond to bits U10 to U0 respectively of the extended next-page unformatted code field.

| EEE_AN_ADV                                  | Offset               | Reset Value       |
|---|----------------------|-------------------|
| EEE Auto-Negotiation Advertisement Register | 07.003C <sub>H</sub> | 0000 <sub>H</sub> |
| 15  |                      | 8                 |
| Res   |                      |                   |
| 7   | 6                    | 5                 |
| 4   | 3                    | 2                 |
| 1   | 0                    |                   |
| Res   | EEE_10GBKR           | EEE_10GBKX<br>4   |
|   | EEE_1000BK<br>X      | EEE_10GBT         |
|   | EEE_1000BT           | EEE_100BTX        |
|   | Res                  |                   |
|   | ro                   | ro                |
|   | ro                   | ro                |
|   | rw                   | rw                |
|   | rw                   |                   |

| Field           | Bits | Type | Description   |
|-----------------|------|------|---|
| EEE_10GBKR      | 6    | RO   | <b>Support of 10GBASE-KR EEE</b><br>0 <sub>B</sub> <b>DISABLED</b> This PHY mode is not supported for EEE<br>1 <sub>B</sub> <b>ENABLE</b> This PHY mode is supported for EEE  |
| EEE_10GBKX<br>4 | 5    | RO   | <b>Support of 10GBASE-KX4 EEE</b><br>0 <sub>B</sub> <b>DISABLED</b> This PHY mode is not supported for EEE<br>1 <sub>B</sub> <b>ENABLE</b> This PHY mode is supported for EEE |
| EEE_1000BK<br>X | 4    | RO   | <b>Support of 1000BASE-KX EEE</b><br>0 <sub>B</sub> <b>DISABLED</b> This PHY mode is not supported for EEE<br>1 <sub>B</sub> <b>ENABLE</b> This PHY mode is supported for EEE |
| EEE_10GBT       | 3    | RO   | <b>Support of 10GBASE-T EEE</b><br>0 <sub>B</sub> <b>DISABLED</b> This PHY mode is not supported for EEE<br>1 <sub>B</sub> <b>ENABLE</b> This PHY mode is supported for EEE   |
| EEE_1000BT      | 2    | RW   | <b>Support of 1000BASE-T EEE</b><br>0 <sub>B</sub> <b>DISABLED</b> This PHY mode is not supported for EEE<br>1 <sub>B</sub> <b>ENABLE</b> This PHY mode is supported for EEE  |
| EEE_100BTX      | 1    | RW   | <b>Support of 100BASE-TX EEE</b><br>0 <sub>B</sub> <b>DISABLED</b> This PHY mode is not supported for EEE<br>1 <sub>B</sub> <b>ENABLE</b> This PHY mode is supported for EEE  |



**EEE Auto-Negotiation Link-Partner Advertisement Register**

All of the bits in the EEE LP advertisement register are read only. A write operation to the EEE LP advertisement register has no effect. After the AN process has been completed, this register reflects the contents of the link partner's EEE advertisement register. The definitions are the same as for the EEE AN advertisement register.

|   |                            |                         |
|---|----------------------------|-------------------------|
| <b>EEE_AN_LPADV</b>   | <b>Offset</b>              | <b>Reset Value</b>      |
| <b>EEE Auto-Negotiation Link-Partner Advertisement Register</b> | <b>07.003D<sub>H</sub></b> | <b>0000<sub>H</sub></b> |

|     |  |            |  |                 |  |                 |   |           |  |            |  |            |  |     |  |
|-----|--|------------|--|-----------------|--|-----------------|---|-----------|--|------------|--|------------|--|-----|--|
| 15  |  |            |  |                 |  |                 | 8 |           |  |            |  |            |  |     |  |
| Res |  |            |  |                 |  |                 |   |           |  |            |  |            |  |     |  |
|     |  |            |  |                 |  |                 |   |           |  |            |  |            |  |     |  |
| 7   |  | 6          |  | 5               |  | 4               |   | 3         |  | 2          |  | 1          |  | 0   |  |
| Res |  | EEE_10GBKR |  | EEE_10GBKX<br>4 |  | EEE_1000BK<br>X |   | EEE_10GBT |  | EEE_1000BT |  | EEE_100BTX |  | Res |  |
| ro  |  | ro         |  | ro              |  | ro              |   | ro        |  | ro         |  | ro         |  | ro  |  |

| Field           | Bits | Type | Description   |
|-----------------|------|------|---|
| EEE_10GBKR      | 6    | RO   | <b>Support of 10GBASE-KR EEE</b><br>0 <sub>B</sub> <b>DISABLED</b> This PHY mode is not supported for EEE<br>1 <sub>B</sub> <b>ENABLE</b> This PHY mode is supported for EEE  |
| EEE_10GBKX<br>4 | 5    | RO   | <b>Support of 10GBASE-KX4 EEE</b><br>0 <sub>B</sub> <b>DISABLED</b> This PHY mode is not supported for EEE<br>1 <sub>B</sub> <b>ENABLE</b> This PHY mode is supported for EEE |
| EEE_1000BK<br>X | 4    | RO   | <b>Support of 1000BASE-KX EEE</b><br>0 <sub>B</sub> <b>DISABLED</b> This PHY mode is not supported for EEE<br>1 <sub>B</sub> <b>ENABLE</b> This PHY mode is supported for EEE |
| EEE_10GBT       | 3    | RO   | <b>Support of 10GBASE-T EEE</b><br>0 <sub>B</sub> <b>DISABLED</b> This PHY mode is not supported for EEE<br>1 <sub>B</sub> <b>ENABLE</b> This PHY mode is supported for EEE   |
| EEE_1000BT      | 2    | RO   | <b>Support of 1000BASE-T EEE</b><br>0 <sub>B</sub> <b>DISABLED</b> This PHY mode is not supported for EEE<br>1 <sub>B</sub> <b>ENABLE</b> This PHY mode is supported for EEE  |
| EEE_100BTX      | 1    | RO   | <b>Support of 100BASE-TX EEE</b><br>0 <sub>B</sub> <b>DISABLED</b> This PHY mode is not supported for EEE<br>1 <sub>B</sub> <b>ENABLE</b> This PHY mode is supported for EEE  |

#### 4.4.4 INTERNAL: Internal Address Space (MMD=0x1F)

This register file contains the PHY internal address space (MMD=0x1F).

##### LED Configuration

This register must be used to configure the complex functions of the LED behavior. Complex functions are of a higher priority than direct LED functions as of registers MMD.INTERNAL.LEDxH/L. When the PHY enters a state defined to activate complex LED functions, all LEDs are controlled according to the type of the complex function.

| LEDCH             | Offset               | Reset Value       |
|-------------------|----------------------|-------------------|
| LED Configuration | 1F.01E0 <sub>H</sub> | 00C5 <sub>H</sub> |
| 15                |                      | 8                 |
| Res               |                      |                   |
| 7                 | 6                    | 5                 |
| 4                 | 3                    | 2                 |
| 0                 |                      |                   |
| FBF               | SBF                  | Res               |
| NACS              |                      |                   |
| rw                | rw                   | rw                |

| Field | Bits | Type | Description  |
|-------|------|------|--|
| FBF   | 7:6  | RW   | <b>Fast Blink Frequency</b><br>This register must be used to configure the fast-blinking frequency. This setting implicitly defines the pulse-stretching width.<br>00 <sub>B</sub> <b>F02HZ</b> 2 Hz blinking frequency<br>01 <sub>B</sub> <b>F04HZ</b> 4 Hz blinking frequency<br>10 <sub>B</sub> <b>F08HZ</b> 8 Hz blinking frequency<br>11 <sub>B</sub> <b>F16HZ</b> 16 Hz blinking frequency |
| SBF   | 5:4  | RW   | <b>Slow Blink Frequency</b><br>This register must be used to configure the slow-blinking frequency.<br>00 <sub>B</sub> <b>F02HZ</b> 2 Hz blinking frequency<br>01 <sub>B</sub> <b>F04HZ</b> 4 Hz blinking frequency<br>10 <sub>B</sub> <b>F08HZ</b> 8 Hz blinking frequency<br>11 <sub>B</sub> <b>F16HZ</b> 16 Hz blinking frequency   |

| Field | Bits | Type | Description  |
|-------|------|------|--|
| NACS  | 2:0  | RW   | <b>Inverse of SCAN Function</b><br>This configuration defines in which state the "complex SCAN" must be activated. The complex SCAN performs running off which turns back and forth between the first and last LED. The speed is dependent on the MMD.INTERNAL.LEDCH.FBF setting.<br>000 <sub>B</sub> <b>NONE</b> No Function<br>001 <sub>B</sub> <b>LINK</b> Complex function enabled when link is up<br>010 <sub>B</sub> <b>PDOWN</b> Complex function enabled when device is powered-down<br>011 <sub>B</sub> <b>EEE</b> Complex function enabled when device is in EEE mode<br>100 <sub>B</sub> <b>ANEG</b> Complex function enabled when auto-negotiation is running<br>101 <sub>B</sub> <b>ABIST</b> Complex function enabled when analog self-test is running<br>110 <sub>B</sub> <b>CDIAG</b> Complex function enabled when cable diagnostics are running<br>111 <sub>B</sub> <b>TEST</b> Complex function enabled when test mode is running |

**LED Configuration**

The register must be used to configure the complex functions of the LED behavior. Complex functions are of a higher priority than direct LED functions as of registers MMD.INTERNAL.LEDxH/L. When the PHY enters a state defined to activate complex LED functions all LEDs are controlled according to the type of the complex function.

| LEDCL             | Offset               | Reset Value       |
|-------------------|----------------------|-------------------|
| LED Configuration | 1F.01E1 <sub>H</sub> | 0067 <sub>H</sub> |
| 15                |                      | 8                 |
| Res               |                      |                   |
| 7                 | 6                    | 4                 |
| 3                 | 2                    | 0                 |
| Res               | SCAN                 | Res               |
|                   | rw                   | CBLINK            |
|                   |                      | rw                |

| Field  | Bits | Type | Description   |
|--------|------|------|---|
| SCAN   | 6:4  | RW   | <p><b>Complex SCAN Configuration</b></p> <p>This configuration defines in which state the "complex SCAN" must be activated. The complex SCAN performs running on which turns back and forth between the first and last LED. The speed is dependent on the MMD.INTERNAL.LEDCH.FBF setting.</p> <p>000<sub>B</sub> <b>NONE</b> No Function<br/>           001<sub>B</sub> <b>LINK</b> Complex function enabled when link is up<br/>           010<sub>B</sub> <b>PDOWN</b> Complex function enabled when device is powered-down<br/>           011<sub>B</sub> <b>EEE</b> Complex function enabled when device is in EEE mode<br/>           100<sub>B</sub> <b>ANEG</b> Complex function enabled when auto-negotiation is running<br/>           101<sub>B</sub> <b>ABIST</b> Complex function enabled when analog self-test is running<br/>           110<sub>B</sub> <b>CDIAG</b> Complex function enabled when cable diagnostics are running<br/>           111<sub>B</sub> <b>TEST</b> Complex function enabled when test mode is running</p>  |
| CBLINK | 2:0  | RW   | <p><b>Complex Blinking Configuration</b></p> <p>This configuration defines in which state the "complex blinking" must be activated. The complex blinking performs a blinking at the fast-blinking frequency on all LEDs simultaneously. This function can be used to indicate a special mode of the PHY such as cable-diagnostics or test. The speed is dependent on the MMD.INTERNAL.LEDCH.FBF setting.</p> <p>000<sub>B</sub> <b>NONE</b> No Function<br/>           001<sub>B</sub> <b>LINK</b> Complex function enabled when link is up<br/>           010<sub>B</sub> <b>PDOWN</b> Complex function enabled when device is powered-down<br/>           011<sub>B</sub> <b>EEE</b> Complex function enabled when device is in EEE mode<br/>           100<sub>B</sub> <b>ANEG</b> Complex function enabled when auto-negotiation is running<br/>           101<sub>B</sub> <b>ABIST</b> Complex function enabled when analog self-test is running<br/>           110<sub>B</sub> <b>CDIAG</b> Complex function enabled when cable diagnostics are running<br/>           111<sub>B</sub> <b>TEST</b> Complex function enabled when test mode is running</p> |

**Configuration for LED Pin 0**

This register configures the behavior of the LED depending on pre-defined states or events the PHY has entered into or raised. Since more than one event/state can be active at the same time, more than one function might apply simultaneously. The priority from highest to lowest is given by the order PULSE, BLINKS, BLINKF, CON.

| LED0H                       | Offset               | Reset Value       |
|-----------------------------|----------------------|-------------------|
| Configuration for LED Pin 0 | 1F.01E2 <sub>H</sub> | 0070 <sub>H</sub> |
| 15                          |                      | 8                 |
| Res                         |                      |                   |
| 7                           | 4                    | 3                 |
| CON                         |                      | BLINKF            |
| rw                          |                      | rw                |

| Field | Bits | Type | Description  |
|-------|------|------|--|
| CON   | 7:4  | RW   | <p><b>Constant On Configuration</b><br/>The Constant-ON field selects in which PHY states the LED is constantly on.</p> <p>0000<sub>B</sub><b>NONE</b> LED does not light up constantly<br/>           0001<sub>B</sub><b>LINK10</b> LED is on when link is 10 Mbps<br/>           0010<sub>B</sub><b>LINK100</b> LED is on when link is 100 Mbps<br/>           0011<sub>B</sub><b>LINK10X</b> LED is on when link is 10/100 Mbps<br/>           0100<sub>B</sub><b>LINK1000</b> LED is on when link is 1000 Mbps<br/>           0101<sub>B</sub><b>LINK10_0</b> LED is on when link is 10/1000 Mbps<br/>           0110<sub>B</sub><b>LINK100X</b> LED is on when link is 100/1000 Mbps<br/>           0111<sub>B</sub><b>LINK10XX</b> LED is on when link is 10/100/1000 Mbps<br/>           1000<sub>B</sub><b>PDOWN</b> LED is on when device is powered-down<br/>           1001<sub>B</sub><b>EEE</b> LED is on when device is in EEE mode<br/>           1010<sub>B</sub><b>ANEG</b> LED is on when auto-negotiation is running<br/>           1011<sub>B</sub><b>ABIST</b> LED is on when analog self-test is running<br/>           1100<sub>B</sub><b>CDIAG</b> LED is on when cable diagnostics are running<br/>           1101<sub>B</sub><b>COPPER</b> LED is on when the COPPER interface is selected<br/>           1110<sub>B</sub><b>FIBER</b> LED is on when the FIBER or an interface other than copper is selected<br/>           1111<sub>B</sub><b>RESERVED</b> Reserved for future use</p> |

| Field  | Bits | Type | Description  |
|--------|------|------|--|
| BLINKF | 3:0  | RW   | <b>Fast Blinking Configuration</b><br>The Blink-F Field selects in which PHY states the LED blinks with the pre-defined fast frequency.<br><br>0000 <sub>B</sub> <b>NONE</b> No Blinking<br>0001 <sub>B</sub> <b>LINK10</b> Blink when link is 10 Mbps<br>0010 <sub>B</sub> <b>LINK100</b> Blink when link is 100 Mbps<br>0011 <sub>B</sub> <b>LINK10X</b> Blink when link is 10/100 Mbps<br>0100 <sub>B</sub> <b>LINK1000</b> Blink when link is 1000 Mbps<br>0101 <sub>B</sub> <b>LINK10_0</b> Blink when link is 10/1000 Mbps<br>0110 <sub>B</sub> <b>LINK100X</b> Blink when link is 100/1000 Mbps<br>0111 <sub>B</sub> <b>LINK10XX</b> Blink when link is 10/100/1000 Mbps<br>1000 <sub>B</sub> <b>PDOWN</b> Blink when device is powered-down<br>1001 <sub>B</sub> <b>EEE</b> Blink when device is in EEE mode<br>1010 <sub>B</sub> <b>ANEG</b> Blink when auto-negotiation is running<br>1011 <sub>B</sub> <b>ABIST</b> Blink when analog self-test is running<br>1100 <sub>B</sub> <b>CDIAG</b> Blink when cable diagnostics are running |

**Similar Registers**

The following registers are identical to the Register [LED0H](#) defined above.

**Table 65 Similar Registers**

| Register Short Name | Register Long Name          | Offset Address       | Reset Value       |
|---------------------|-----------------------------|----------------------|-------------------|
| LED1H               | Configuration for LED Pin 1 | 1F.01E4 <sub>H</sub> | 0020 <sub>H</sub> |
| LED2H               | Configuration for LED Pin 2 | 1F.01E6 <sub>H</sub> | 0040 <sub>H</sub> |
| LED3H               | Configuration for LED Pin 3 | 1F.01E8 <sub>H</sub> | 0040 <sub>H</sub> |

**Configuration for LED Pin 0**

This register configures the behavior of the LED depending on pre-defined states or events the PHY has entered into or raised. Since more than one event or state can be active at the same time, more than one function might apply simultaneously. The priority from highest to lowest is given by the order PULSE, BLINKS, BLINKF, CON.

| LED0L                       | Offset               | Reset Value       |
|-----------------------------|----------------------|-------------------|
| Configuration for LED Pin 0 | 1F.01E3 <sub>H</sub> | 0003 <sub>H</sub> |
| 15                          |                      | 8                 |
| Res                         |                      |                   |
| 7                           | 4                    | 3                 |
| BLINKS                      |                      | PULSE             |
| rw                          |                      | rw                |

| Field  | Bits | Type | Description   |
|--------|------|------|---|
| BLINKS | 7:4  | RW   | <p><b>Slow Blinking Configuration</b></p> <p>The Blink-S field selects in which PHY states the LED blinks with the pre-defined slow frequency.</p> <p>0000<sub>B</sub><b>NONE</b> No Blinking<br/>           0001<sub>B</sub><b>LINK10</b> Blink when link is 10 Mbps<br/>           0010<sub>B</sub><b>LINK100</b> Blink when link is 100 Mbps<br/>           0011<sub>B</sub><b>LINK10X</b> Blink when link is 10/100 Mbps<br/>           0100<sub>B</sub><b>LINK1000</b> Blink when link is 1000 Mbps<br/>           0101<sub>B</sub><b>LINK10_0</b> Blink when link is 10/1000 Mbps<br/>           0110<sub>B</sub><b>LINK100X</b> Blink when link is 100/1000 Mbps<br/>           0111<sub>B</sub><b>LINK10XX</b> Blink when link is 10/100/1000 Mbps<br/>           1000<sub>B</sub><b>PDOWN</b> Blink when device is powered-down<br/>           1001<sub>B</sub><b>EEE</b> Blink when device is in EEE mode<br/>           1010<sub>B</sub><b>ANEG</b> Blink when auto-negotiation is running<br/>           1011<sub>B</sub><b>ABIST</b> Blink when analog self-test is running<br/>           1100<sub>B</sub><b>CDIAG</b> Blink when cable diagnostics are running</p> |
| PULSE  | 3:0  | RW   | <p><b>Pulsing Configuration</b></p> <p>The pulse field is a mask field by which certain events can be combined, e.g. TXACT RXACT, to generate a pulse on the LED in case such an event has been detected.</p> <p>0000<sub>B</sub><b>NONE</b> No pulsing<br/>           0001<sub>B</sub><b>TXACT</b> Transmit activity<br/>           0010<sub>B</sub><b>RXACT</b> Receive activity<br/>           0100<sub>B</sub><b>COL</b> Collision<br/>           1000<sub>B</sub><b>RES</b> Reserved</p>   |

**Similar Registers**

The following registers are identical to the Register [LED0L](#) defined above.

**Table 66 Similar Registers**

| Register Short Name | Register Long Name          | Offset Address       | Reset Value       |
|---------------------|-----------------------------|----------------------|-------------------|
| LED1L               | Configuration for LED Pin 1 | 1F.01E5 <sub>H</sub> | 0000 <sub>H</sub> |
| LED2L               | Configuration for LED Pin 2 | 1F.01E7 <sub>H</sub> | 0000 <sub>H</sub> |
| LED3L               | Configuration for LED Pin 3 | 1F.01E9 <sub>H</sub> | 0020 <sub>H</sub> |

**High Byte of the EEE Link-Fail Counter**

High Byte of the EEE Link-Fail Counter.

| EEE_RXERR_LINK_FAIL_H                  | Offset               | Reset Value       |
|--|----------------------|-------------------|
| High Byte of the EEE Link-Fail Counter | 1F.01EA <sub>H</sub> | 0000 <sub>H</sub> |
| 15                                     |                      | 8                 |
|  | Res                  |                   |
| 7                                      |                      | 0                 |
|  | VAL                  |                   |
|  | ro                   |                   |

| Field | Bits | Type | Description  |
|-------|------|------|--|
| VAL   | 7:0  | RO   | <b>VAL</b><br>High byte of the EEE_RXERR_LINK_FAIL counter. A read access to the low byte also clears the high byte of this counter. |

**Low Byte of the EEE Link-Fail Counter**

Low Byte of the EEE Link-Fail Counter.

| EEE_RXERR_LINK_FAIL_L                 | Offset               | Reset Value       |
|---------------------------------------|----------------------|-------------------|
| Low Byte of the EEE Link-Fail Counter | 1F.01EB <sub>H</sub> | 0000 <sub>H</sub> |
| 15                                    |                      | 8                 |
|                                       | Res                  |                   |
| 7                                     |                      | 0                 |
|                                       | VAL                  |                   |
|                                       | ro                   |                   |

| Field | Bits | Type | Description  |
|-------|------|------|--|
| VAL   | 7:0  | RO   | <b>VAL</b><br>Low byte of the EEE_RXERR_LINK_FAIL counter. A read access to this byte also clears the high byte of this counter. |



**Wake-On-LAN Control Register**

Wake-On-LAN Control Register.

| WOLCTRL                      | Offset               | Reset Value       |
|------------------------------|----------------------|-------------------|
| Wake-On-LAN Control Register | 1F.0781 <sub>H</sub> | 0000 <sub>H</sub> |
| 15                           |                      | 8                 |
| Res                          |                      |                   |
| 7                            | 3                    | 2 1 0             |
|                              | Res                  | SPWD_EN RES EN    |
|                              |                      | rw ro rw          |

| Field   | Bits | Type | Description  |
|---------|------|------|--|
| SPWD_EN | 2    | RW   | <b>Secure-ON Password Enable</b><br>When enabled, checks for the Secure-ON password after the 16 MAC address repetitions.<br>0 <sub>B</sub> <b>DISABLED</b> Secure-On password check is disabled<br>1 <sub>B</sub> <b>ENABLED</b> Secure-On password check is enabled  |
| RES     | 1    | RO   | <b>Reserved</b><br>Must always be written to zero!   |
| EN      | 0    | RW   | <b>Wake-On-LAN Enable</b><br>When Wake-On-LAN is enabled, the PHY scans for the configured magic packet and indicates its reception via the register bit ISTAT.WOL, and optionally also via interrupt.<br>0 <sub>B</sub> <b>DISABLED</b> Wake-On-LAN functionality is disabled<br>1 <sub>B</sub> <b>ENABLED</b> Wake-On-LAN functionality is enabled |

**Wake-On-LAN Address Byte 0**

Wake-On-LAN Address Byte 0.

| WOLAD0                     | Offset               | Reset Value       |
|----------------------------|----------------------|-------------------|
| Wake-On-LAN Address Byte 0 | 1F.0783 <sub>H</sub> | 0000 <sub>H</sub> |
| 15                         |                      | 8                 |
|                            | Res                  |                   |
| 7                          |                      | 0                 |
|                            | AD0                  |                   |
|                            | rw                   |                   |

| Field | Bits | Type | Description  |
|-------|------|------|--|
| AD0   | 7:0  | RW   | <b>Address Byte 0</b><br>Defines byte 0 of the WOL-designated MAC address to which the PHY is sensitive. |

**Similar Registers**

The following registers are identical to the Register **WOLAD0** defined above.

**Table 67 Similar Registers**

| Register Short Name | Register Long Name         | Offset Address       | Reset Value       |
|---------------------|----------------------------|----------------------|-------------------|
| WOLAD1              | Wake-On-LAN Address Byte 1 | 1F.0784 <sub>H</sub> | 0000 <sub>H</sub> |
| WOLAD2              | Wake-On-LAN Address Byte 2 | 1F.0785 <sub>H</sub> | 0000 <sub>H</sub> |
| WOLAD3              | Wake-On-LAN Address Byte 3 | 1F.0786 <sub>H</sub> | 0000 <sub>H</sub> |
| WOLAD4              | Wake-On-LAN Address Byte 4 | 1F.0787 <sub>H</sub> | 0000 <sub>H</sub> |
| WOLAD5              | Wake-On-LAN Address Byte 5 | 1F.0788 <sub>H</sub> | 0000 <sub>H</sub> |

**Wake-On-LAN SecureON Password Byte 0**

Wake-On-LAN SecureON Password Byte 0.

| <b>WOLPW0</b>                               | <b>Offset</b>              | <b>Reset Value</b>      |
|---|----------------------------|-------------------------|
| <b>Wake-On-LAN SecureON Password Byte 0</b> | <b>1F.0789<sub>H</sub></b> | <b>0000<sub>H</sub></b> |
| 15  |                            | 8                       |
| <b>Res</b>                                  |                            |                         |
| 7   |                            | 0                       |
| <b>PW0</b>                                  |                            |                         |
| rw  |                            |                         |

| <b>Field</b> | <b>Bits</b> | <b>Type</b> | <b>Description</b>   |
|--------------|-------------|-------------|--|
| PW0          | 7:0         | RW          | <b>SecureON Password Byte 0</b><br>Defines byte 0 of the WOL-designated SecureON password to which the PHY is sensitive. |

**Similar Registers**

The following registers are identical to the Register **WOLPW0** defined above.

**Table 68 Similar Registers**

| <b>Register Short Name</b> | <b>Register Long Name</b>            | <b>Offset Address</b> | <b>Reset Value</b> |
|----------------------------|--------------------------------------|-----------------------|--------------------|
| WOLPW1                     | Wake-On-LAN SecureON Password Byte 1 | 1F.078A <sub>H</sub>  | 0000 <sub>H</sub>  |
| WOLPW2                     | Wake-On-LAN SecureON Password Byte 2 | 1F.078B <sub>H</sub>  | 0000 <sub>H</sub>  |
| WOLPW3                     | Wake-On-LAN SecureON Password Byte 3 | 1F.078C <sub>H</sub>  | 0000 <sub>H</sub>  |
| WOLPW4                     | Wake-On-LAN SecureON Password Byte 4 | 1F.078D <sub>H</sub>  | 0000 <sub>H</sub>  |
| WOLPW5                     | Wake-On-LAN SecureON Password Byte 5 | 1F.078E <sub>H</sub>  | 0000 <sub>H</sub>  |

**Configuration for Synchronous Ethernet**

This register allow management configuration of the SyncE clocking reference

| PD_CTL                                 | Offset               | Reset Value       |             |           |
|--|----------------------|-------------------|-------------|-----------|
| Configuration for Synchronous Ethernet | 1F.07FE <sub>H</sub> | 0000 <sub>H</sub> |             |           |
| 15                                     |                      | 8                 |             |           |
| Res                                    |                      |                   |             |           |
| 7                                      | 4                    | 3                 |             |           |
|  | 2                    | 1                 |             |           |
|  |                      | 0                 |             |           |
|  | <b>THR</b>           | <b>CLKSEL</b>     | <b>HOLD</b> | <b>EN</b> |
|  | rw                   | rw                | rw          | rw        |

| Field  | Bits | Type | Description   |
|--------|------|------|---|
| THR    | 7:4  | RW   | <b>THR</b><br>Control the Threshold for detection of Lost of Reference clock.   |
| CLKSEL | 3:2  | RW   | <b>CLKSEL</b><br>This enable management selection of the type of reference clock we are receiving<br>00 <sub>B</sub> <b>AN1</b> Reference clock is 8 kHz. Special request for AN application<br>01 <sub>B</sub> <b>EEC1</b> Reference clock is 2.048 MHz according to EEC-Option 1<br>10 <sub>B</sub> <b>EEC2</b> Reference clock is 1.544 MHz according to EEC-Option 2<br>11 <sub>B</sub> <b>AN2</b> Reserved |
| HOLD   | 1    | RW   | <b>HOLD</b><br>Force the SyncE into HOLD over mode. This is the mode we enter when we detect Lost of reference. To hold the adapted Frequency so that we are able to sustain the reference clock generation within error of 4.6ppm.<br>0 <sub>B</sub> <b>NORM</b> HW control of the entry/exit of Hold-Over mode<br>1 <sub>B</sub> <b>FHOLD</b> Force Hold Over mode  |
| EN     | 0    | RW   | <b>EN</b><br>Enable Synchronous Ethernet Support<br>0 <sub>B</sub> <b>DISABLE</b> Normal Ethernet operation<br>1 <sub>B</sub> <b>ENABLE</b> SyncE is enabled  |

## 5 Electrical Characteristics

This chapter defines the electrical characteristics to which the Gigabit Ethernet Switch device conforms.

*Note: This chapter is subject to change.*

### 5.1 Absolute Maximum Ratings

**Table 69** shows the absolute maximum ratings for the Gigabit Ethernet Switch.

**Attention: Stresses above the maximum values listed in this table may cause permanent damage to the device. Exposure to absolute maximum rating conditions for extended periods may affect device reliability. Maximum ratings are absolute ratings; exceeding only one of these values may cause irreversible damage to the device.**

**Table 69 Absolute Limit Ratings**

| Parameter  | Symbol        | Values |      |               | Unit | Note / Test Condition                    |
|--|---------------|--------|------|---------------|------|--|
|  |               | Min.   | Typ. | Max.          |      |  |
| Storage Temperature Limits   | $T_{STG}$     | -55.0  | –    | 125.0         | °C   | –  |
| Moisture Level 3 Temperature Limits                                      | $T_{ML3}$     | –      | –    | 260.0         | °C   | According to IPS J-STD 020               |
| DC Voltage Limits on VDDP Pins   | $V_{DDP}$     | -0.5   | –    | +3.6          | V    | –  |
| DC Voltage Limits on VDDH Pins   | $V_{DDH}$     | -0.5   | –    | +3.6          | V    | –  |
| DC Voltage Limits on VDDA Pins   | $V_{DDA}$     | -0.5   | –    | +3.6          | V    | –  |
| DC Voltage Limits on VDDR Pins   | $V_{DDR}$     | -0.5   | –    | +3.6          | V    | –  |
| DC Voltage Limits on VDDL Pins   | $V_{DDL}$     | -0.5   | –    | +1.26         | V    | –  |
| DC Voltage Limits on VDDS Pins   | $V_{DDS}$     | -0.5   | –    | +1.26         | V    | –  |
| DC Voltage Limits on VDD Pins  | $V_{DD}$      | -0.5   | –    | +1.26         | V    | –  |
| DC Voltage Limits on Any Other Pins <sup>1)</sup> With Respect to Ground | $V_{DC}$      | -0.5   | –    | $V_{DDx}+0.5$ | V    | Unless specified otherwise               |
| ESD HBM Robustness   | $V_{ESD,HBM}$ | –      | –    | 1000.0        | V    | According to ANSI/ESDA/JEDEC JS-001-2014 |
| ESD CDM Robustness   | $V_{ESD,CDM}$ | –      | –    | 250.0         | V    | According to JEDEC JESD22-C101           |

1) This means any pin which is not a supply pin out of one of the domains:  $V_{DDP}$ ,  $V_{DDA}$ ,  $V_{DDH}$ ,  $V_{DDR}$ ,  $V_{DDL}$ ,  $V_{DD}$ .

## 5.2 Operating Range

**Table 70** defines the limit values of voltages and temperature which may be applied to guarantee proper operation of the Gigabit Ethernet Switch.

**Table 70 Operating Range**

| Parameter                                 | Symbol    | Values |      |               | Unit | Note / Test Condition  |
|---|-----------|--------|------|---------------|------|--|
|   |           | Min.   | Typ. | Max.          |      |  |
| Ambient Temperature Under Bias            | $T_A$     | -40.0  | –    | 85.0          | °C   | Thermal solution must ensure that $T_j$ remains within operating range and never exceeds maximum absolute ratings. |
| Junction Temperature                      | $T_j$     | –      | –    | 125.0         | °C   |  |
| Pad Supply Voltage                        | $V_{DDP}$ | 3.20   | 3.30 | 3.39          | V    | 3.3 V supply; $\pm 3\%$  |
| High Supply Voltage                       | $V_{DDH}$ | 3.20   | 3.30 | 3.39          | V    | 3.3 V supply; $\pm 3\%$  |
| XO High Supply Voltage                    | $V_{DDA}$ | 3.20   | 3.30 | 3.39          | V    | 3.3 V supply; $\pm 3\%$  |
| RGMII PAD Supply Voltage                  | $V_{DDR}$ | 3.20   | 3.30 | 3.39          | V    | 3.3 V supply; $\pm 3\%$  |
|   |           | 2.43   | 2.50 | 2.57          | V    | 2.5 V supply; $\pm 3\%$  |
| Low Supply Voltage                        | $V_{DDL}$ | 1.07   | 1.07 | 1.13          | V    | 1.1 V supply; $\pm 3\%$  |
| SGMII Low Supply Voltage                  | $V_{DDS}$ | 1.07   | 1.07 | 1.13          | V    | 1.1 V supply; $\pm 3\%$  |
| Core Supply Voltage                       | $V_{DD}$  | 1.07   | 1.07 | 1.13          | V    | 1.1 V supply; $\pm 3\%$  |
| Digital Input Voltage (Except RGMII Pins) | $V_{ID}$  | -0.30  | –    | $V_{DDP}+0.3$ | V    | –  |
| Digital Input Voltage (RGMII Pins)        | $V_{ID}$  | 0.00   | –    | $V_{DDR}$     | V    | –  |
| XTAL1 Input Voltage                       | $V_{ID}$  | -0.30  | –    | $V_{DDA}+0.3$ | V    | –  |
| Ground                                    | $V_{SS}$  | 0.00   | 0.00 | 0.00          | V    | –  |

**Attention: Operations above the max. values listed here for extended periods can adversely affect long-term reliability of the device.**

### 5.3 Power Consumption

**Attention:** The Reset Request Register (**RST\_REQ**) bits 2 and 3 must always be written as '1'.

**Table 71 Power Consumption**

| Parameter   | Symbol            | Values |      |      | Unit | Note / Test Condition  |
|---|-------------------|--------|------|------|------|--|
|   |                   | Min.   | Typ. | Max. |      |  |
| <b>MAX POWER CASE: 2-GPHY-ports 1G link+traffic, 100m cable; SGMII+ traffic, RGMII traffic</b>            |                   |        |      |      |      |  |
|   | $I_{DDH}$         | –      | 160  | 180  | mA   | $V_{DDH} = 3.3\text{ V}, T_A = 25\text{ }^\circ\text{C}$         |
|   | $I_{DDL}$         | –      | 240  | 260  | mA   | $V_{DDL} = 1.1\text{ V}, T_A = 25\text{ }^\circ\text{C}$         |
|   | $I_{DD/DDS}$      | –      | 460  | 510  | mA   | $V_{DD/DDS} = 1.1\text{ V}, T_A = 25\text{ }^\circ\text{C}$      |
|   | $I_{DDP/DDR/DDA}$ | –      | 7    | 10   | mA   | $V_{DDP/DDR/DDA} = 3.3\text{ V}, T_A = 25\text{ }^\circ\text{C}$ |
| <b>10m POWER CASE: 2-GPHY-ports 1G link+traffic, 10m cable; SGMII+ traffic, RGMII traffic</b>             |                   |        |      |      |      |  |
|   | $I_{DDH}$         | –      | 160  | 180  | mA   | $V_{DDH} = 3.3\text{ V}, T_A = 25\text{ }^\circ\text{C}$         |
|   | $I_{DDL}$         | –      | 220  | 250  | mA   | $V_{DDL} = 1.1\text{ V}, T_A = 25\text{ }^\circ\text{C}$         |
|   | $I_{DD/DDS}$      | –      | 420  | 480  | mA   | $V_{DD/DDS} = 1.1\text{ V}, T_A = 25\text{ }^\circ\text{C}$      |
|   | $I_{DDP/DDR/DDA}$ | –      | 7    | 10   | mA   | $V_{DDP/DDR/DDA} = 3.3\text{ V}, T_A = 25\text{ }^\circ\text{C}$ |
| <b>100BASE-T POWER CASE: 2-GPHY-ports 100Mbps link+traffic, 100m cable; SGMII+ traffic, RGMII traffic</b> |                   |        |      |      |      |  |
|   | $I_{DDH}$         | –      | 88   | 100  | mA   | $V_{DDH} = 3.3\text{ V}, T_A = 25\text{ }^\circ\text{C}$         |
|   | $I_{DDL}$         | –      | 130  | 150  | mA   | $V_{DDL} = 1.1\text{ V}, T_A = 25\text{ }^\circ\text{C}$         |
|   | $I_{DD/DDS}$      | –      | 240  | 260  | mA   | $V_{DD/DDS} = 1.1\text{ V}, T_A = 25\text{ }^\circ\text{C}$      |
|   | $I_{DDP/DDR/DDA}$ | –      | 7    | 10   | mA   | $V_{DDP/DDR/DDA} = 3.3\text{ V}, T_A = 25\text{ }^\circ\text{C}$ |
| <b>EEE NO-TRAFFIC POWER CASE: 2-GPHY-ports 1G link no-traffic, SGMII+ IDLE, RGMII IDLE</b>                |                   |        |      |      |      |  |
|   | $I_{DDH}$         | –      | 60   | 75   | mA   | $V_{DDH} = 3.3\text{ V}, T_A = 25\text{ }^\circ\text{C}$         |
|   | $I_{DDL}$         | –      | 110  | 125  | mA   | $V_{DDL} = 1.1\text{ V}, T_A = 25\text{ }^\circ\text{C}$         |
|   | $I_{DD/DDS}$      | –      | 280  | 310  | mA   | $V_{DD/DDS} = 1.1\text{ V}, T_A = 25\text{ }^\circ\text{C}$      |
|   | $I_{DDP/DDR/DDA}$ | –      | 7    | 10   | mA   | $V_{DDP/DDR/DDA} = 3.3\text{ V}, T_A = 25\text{ }^\circ\text{C}$ |
| <b>NO-LINK POWER CASE: 2-GPHY-ports no-link+traffic, SGMII+ IDLE, RGMII IDLE</b>                          |                   |        |      |      |      |  |
|   | $I_{DDH}$         | –      | 55   | 60   | mA   | $V_{DDH} = 3.3\text{ V}, T_A = 25\text{ }^\circ\text{C}$         |
|   | $I_{DDL}$         | –      | 80   | 90   | mA   | $V_{DDL} = 1.1\text{ V}, T_A = 25\text{ }^\circ\text{C}$         |
|   | $I_{DD/DDS}$      | –      | 230  | 259  | mA   | $V_{DD/DDS} = 1.1\text{ V}, T_A = 25\text{ }^\circ\text{C}$      |
|   | $I_{DDP/DDR/DDA}$ | –      | 7    | 10   | mA   | $V_{DDP/DDR/DDA} = 3.3\text{ V}, T_A = 25\text{ }^\circ\text{C}$ |
| <b>RESET POWER CASE: 2-GPHY-ports Reset, SGMII+ Reset, RGMII Reset</b>                                    |                   |        |      |      |      |  |
|   | $I_{DDH}$         | –      | 23   | 30   | mA   | $V_{DDH} = 3.3\text{ V}, T_A = 25\text{ }^\circ\text{C}$         |
|   | $I_{DDL}$         | –      | 7    | 10   | mA   | $V_{DDL} = 1.1\text{ V}, T_A = 25\text{ }^\circ\text{C}$         |
|   | $I_{DD/DDS}$      | –      | 10   | 15   | mA   | $V_{DD/DDS} = 1.1\text{ V}, T_A = 25\text{ }^\circ\text{C}$      |
|   | $I_{DDP/DDR/DDA}$ | –      | 1    | 3    | mA   | $V_{DDP/DDR/DDA} = 3.3\text{ V}, T_A = 25\text{ }^\circ\text{C}$ |

## 5.4 DC Characteristics

The following sections investigate the DC characteristics of the Gigabit Ethernet Switch external interfaces.

### 5.4.1 Digital Interfaces

This section defines the DC characteristics of the digital interfaces.

#### 5.4.1.1 GPIO Interfaces

This section defines the DC characteristics of the GPIO Interface comprised of the following interfaces.

- MDIO
- SPI
- UART
- Interrupts
- Clock Outputs
- General Purpose IO
- LED
- JTAG

**Table 72** summarizes the DC characteristics for  $V_{DDP}=3.3$  V.

**Table 72 DC Characteristics of the GPIO Interfaces (VDDP=3.3V)**

| Parameter           | Symbol   | Values              |      |                     | Unit | Note / Test Condition    |
|---------------------|----------|---------------------|------|---------------------|------|--------------------------|
|                     |          | Min.                | Typ. | Max.                |      |                          |
| Input High Voltage  | $V_{IH}$ | $0.7 \cdot V_{DDP}$ | –    | $V_{DDP}+0.3$       | V    | –                        |
| Input Low Voltage   | $V_{IL}$ | –0.3                | –    | $0.3 \cdot V_{DDP}$ | V    | –                        |
| Output High Voltage | $V_{OH}$ | $V_{DDP}-0.4$       | –    | –                   | V    | $I_{OH}= 2, 4, 8, 12$ mA |
| Output Low Voltage  | $V_{OL}$ | –                   | –    | 0.4                 | V    | $I_{OL}= 2, 4, 8, 12$ mA |

#### 5.4.1.2 RGMII Transmit Interface

This section defines the DC characteristics of the RGMII transmit Interface. **Table 73** summarizes the DC characteristics valid for  $V_{DDR}=2.5$  V and  $V_{DDR}=3.3$  V.

**Table 73 DC Characteristics of the Transmit RGMII Interface**

| Parameter           | Symbol   | Values |      |               | Unit | Note / Test Condition |
|---------------------|----------|--------|------|---------------|------|-----------------------|
|                     |          | Min.   | Typ. | Max.          |      |                       |
| Output High Voltage | $V_{OH}$ | 2.1    | –    | $V_{DDR}+0.3$ | V    | 5 pF                  |
| Output Low Voltage  | $V_{OL}$ | 0      | –    | 0.5           | V    | 5 pF                  |



### 5.4.1.3 RGMII Receive Interface

This section defines the DC characteristics of the RGMII receive Interface. [Table 74](#) summarizes the DC characteristics valid for  $V_{\text{DDR}}=2.5\text{ V}$  and  $V_{\text{DDR}}=3.3\text{ V}$ .

**Table 74 DC Characteristics of the Receive RGMII Interface**

| Parameter          | Symbol          | Values |      |      | Unit | Note / Test Condition |
|--------------------|-----------------|--------|------|------|------|-----------------------|
|                    |                 | Min.   | Typ. | Max. |      |                       |
| Input High Voltage | $V_{\text{IH}}$ | 1.7    | –    | –    | V    | –                     |
| Input Low Voltage  | $V_{\text{IL}}$ |        | –    | 0.7  | V    | –                     |

## 5.5 AC Characteristics

The following sections describe the AC characteristics of the external interfaces. The load capacitors are according to the specific interface standard. All non-specified interfaces use 30 pF as assumed loading.

### 5.5.1 Reset

Gigabit Ethernet Switch supports an asynchronous hardware reset HRSTN. **Table 75** lists the timing requirements on the HRSTN pin to the GSW125. **Figure 47** depicts the signal sequence waveforms illustrating the timings.

It is recommended that the voltage 3.3 V powers up before voltage 1.1 V. Voltage 1.1 V must never be higher than voltage 3.3 V ramp. Voltage 1.1 V must power up within  $t_{up}$  after 3.3 V powers up. After the power-supply settling time, all primary input signals to the GSW125 must be defined. In particular, this is valid for the device reset HRSTN. This reset must be held for a  $t_{reset}$  time. After releasing the reset, the integrated PLL locks on the reference clock and the device boots up.

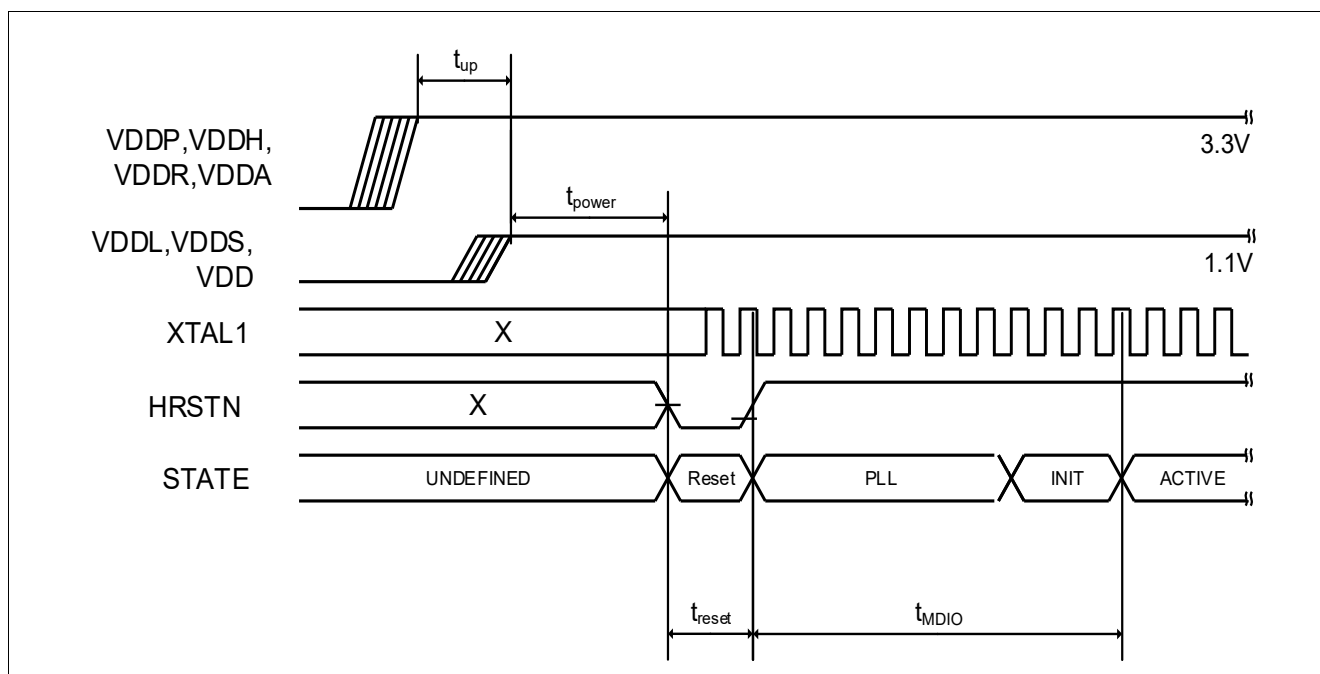

**Figure 47** Timing Diagram for the GSW125 Reset Sequence

**Table 75** AC Characteristics of the HRSTN Pin

| Parameter                             | Symbol      | Values |      |       | Unit | Note / Test Condition |
|---------------------------------------|-------------|--------|------|-------|------|-----------------------|
|                                       |             | Min.   | Typ. | Max.  |      |                       |
| Power Supply Sequence Time            | $t_{up}$    | –      | –    | 100.0 | ms   | –                     |
| Power Supply Settling Time            | $t_{power}$ | –      | –    | 50.0  | ms   | –                     |
| Reset Time                            | $t_{reset}$ | 200.0  | –    | –     | ms   | –                     |
| First MDIO Access after Reset Release | $t_{MDIO}$  | 300.0  | –    | –     | ms   | –                     |

## 5.5.2 Power Supply

**Table 76** lists the AC characteristics of the power supplies.

**Table 76 AC Characteristics of the Power Supply**

| Parameter                   | Symbol     | Values |      |       | Unit | Note / Test Condition |
|-----------------------------|------------|--------|------|-------|------|-----------------------|
|                             |            | Min.   | Typ. | Max.  |      |                       |
| Power Supply Ripple on VDDL | $R_{VDDL}$ | –      | –    | 30.0  | mV   | Peak value            |
| Power Supply Ripple on VDDS | $R_{VDDL}$ | –      | –    | 30.0  | mV   | Peak value            |
| Power Supply Ripple on VDD  | $R_{VDD}$  | –      | –    | 30.0  | mV   | Peak value            |
| Power Supply Ripple on VDDP | $R_{VDDP}$ | –      | –    | 100.0 | mV   | Peak value            |
| Power Supply Ripple on VDDH | $R_{VDDH}$ | –      | –    | 30.0  | mV   | Peak value            |
| Power Supply Ripple on VDDA | $R_{VDDH}$ | –      | –    | 30.0  | mV   | Peak value            |
| Power Supply Ripple on VDDR | $R_{VDDR}$ | –      | –    | 100.0 | mV   | Peak value            |

## 5.5.3 Input Clock

**Table 77** lists the input clock requirements when not using a crystal, i.e. when an external reference clock is injected into the XTAL1 pin of the Gigabit Ethernet Switch, e.g. nominal frequency, frequency deviation, duty cycle and signal characteristics. When a crystal is applied to generate the reference clock using the integrated XO, the clock requirements stated here are explicitly met as long as the specification for the crystal is satisfied.

**Table 77 AC Characteristics of Input Clock on XTAL1 pin**

| Parameter                   | Symbol      | Values |      |           | Unit | Note / Test Condition |
|-----------------------------|-------------|--------|------|-----------|------|-----------------------|
|                             |             | Min.   | Typ. | Max.      |      |                       |
| Frequency with 25 MHz Input | $f_{clk25}$ | –      | 25.0 | –         | MHz  | –                     |
| Frequency with 40 MHz Input | $f_{clk40}$ | –      | 40.0 | –         | MHz  | –                     |
| Frequency Deviation         |             | -50.0  | –    | +50.0     | ppm  | –                     |
| Duty Cycle                  |             | 45.0   | 50.0 | 55.0      | %    | –                     |
| XTAL1 Input Swing           |             | 0.9    | -    | $V_{DDA}$ | V    | –                     |
| Rise/Fall-Times             |             | –      | –    | 2.0       | ns   | -                     |

## 5.5.4 Output Clock

**Table 78** lists the output clock requirements on the GPC pin from the Gigabit Ethernet Switch, e.g. nominal frequency, frequency deviation, duty cycle and signal characteristics.

**Table 78 AC Characteristics of Output Clock on GPC pin**

| Parameter           | Symbol | Values |      |       | Unit | Note / Test Condition |
|---------------------|--------|--------|------|-------|------|-----------------------|
|                     |        | Min.   | Typ. | Max.  |      |                       |
| Frequency Deviation |        | -50.0  | –    | +50.0 | ppm  | –                     |
| Duty Cycle          |        | 45.0   | 50.0 | 55.0  | %    | –                     |
| Rise/Fall-Times     |        | –      | –    | 2.0   | ns   | 10 pF load            |

### 5.5.5 MDIO Interface

**Figure 48** shows a timing diagram of the MDIO interface for a clock cycle in the read-, write- and turnaround-modus, respectively. The timing measures are annotated. **Table 79** summarizes the defined absolute values.

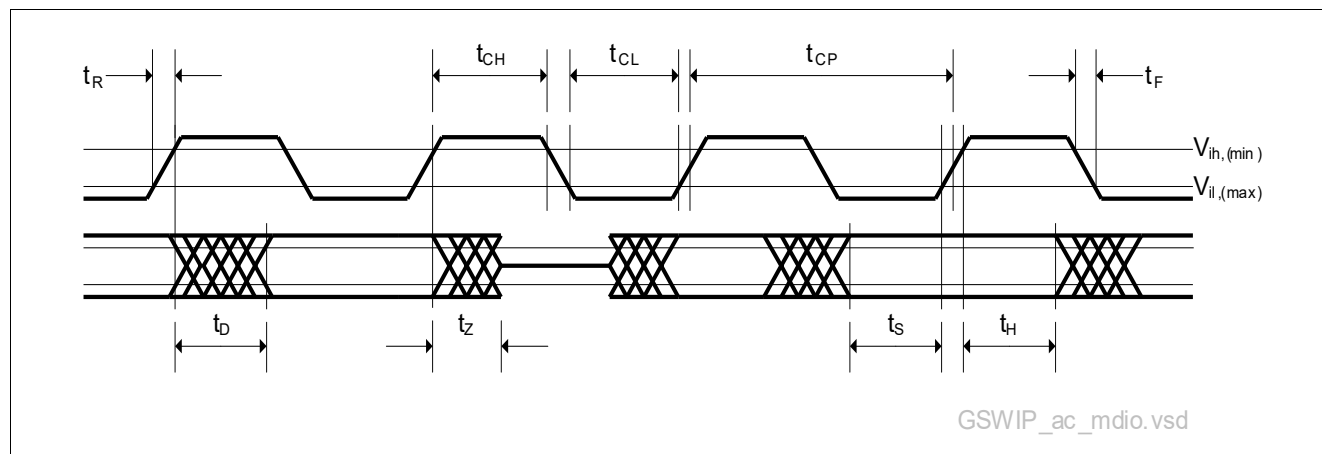

**Figure 48** Timing Diagram for the MDIO Interface

**Table 79** Timing Characteristics of the MDIO Interface

| Parameter                               | Symbol   | Values |       |             | Unit | Note / Test Condition   |
|---|----------|--------|-------|-------------|------|---|
|   |          | Min.   | Typ.  | Max.        |      |   |
| MDC High Time                           | $t_{CH}$ | 10.0   | –     | –           | ns   | Given timings are all subject to the MDC at the pin of the Gigabit Ethernet Switch. |
| MDC Low Time                            | $t_{CL}$ | 10.0   | –     | –           | ns   |   |
| MDC Clock Period                        | $t_{CP}$ | 58.8   | 400.0 | –           | ns   |   |
| MDC Clock Frequency <sup>1)</sup>       | $t_{CP}$ | –      | 2.5   | 17.0        | MHz  |   |
| MDC Rise Time                           | $t_R$    | –      | –     | 5.0         | ns   |   |
| MDC Fall Time                           | $t_F$    | –      | –     | 5.0         | ns   |   |
| MDIO Input Setup Time subject to ↑ MDC  | $t_S$    | 10.0   | –     | –           | ns   | Gigabit Ethernet Switch receive   |
| MDIO Input Hold Time subject to ↑ MDC   | $t_H$    | 0.0    | –     | –           | ns   | Gigabit Ethernet Switch receive   |
| MDIO Output Delay subject to ↑ MDC      | $t_D$    | 10.0   | –     | $t_{CP}-10$ | ns   | Gigabit Ethernet Switch transmit  |
| <b>Standard at 2.5 MHz</b>              |          |        |       |             |      |   |
| MDIO Output Delay subject to ↑ MDC      | $t_D$    | 0.0    | –     | 300.0       | ns   | PHY transmit  |
| MDIO Output Setup Time subject to ↑ MDC | $t_S$    | 10.0   | –     | –           | ns   | MAC transmit  |
| MDIO Output Hold Time subject to ↑ MDC  | $t_H$    | 10.0   | –     | –           | ns   | MAC transmit  |

1) MDC clock supports range of frequencies, up to 25 MHz. Default/typical frequency is 2.5 MHz.

### 5.5.6 SMDIO Interface

Figure 49 shows a timing diagram of the SMDIO interface for a clock cycle in the read-, write- and turnaround-modus, respectively. The timing measures are annotated. Table 80 summarizes the defined absolute values.

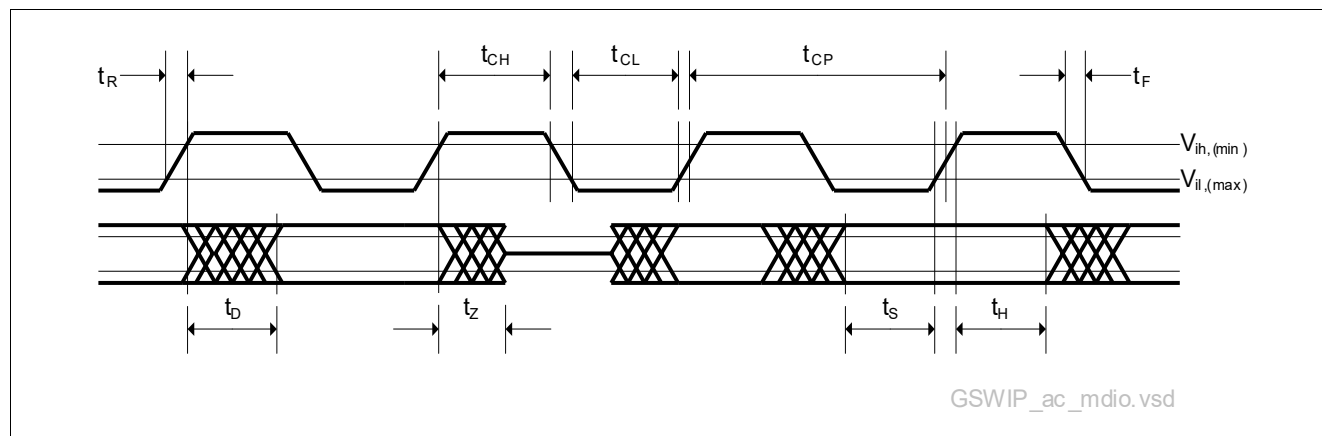

Figure 49 Timing Diagram for the SMDIO Interface

Table 80 Timing Characteristics of the SMDIO Interface

| Parameter                               | Symbol   | Values |       |       | Unit | Note / Test Condition   |
|---|----------|--------|-------|-------|------|---|
|   |          | Min.   | Typ.  | Max.  |      |   |
| MDC High Time                           | $t_{CH}$ | 10.0   | –     | –     | ns   | Given timings are all subject to the MDC at the pin of the Gigabit Ethernet Switch. |
| MDC Low Time                            | $t_{CL}$ | 10.0   | –     | –     | ns   |   |
| MDC Clock Period                        | $t_{CP}$ | 40.0   | 400.0 | –     | ns   |   |
| MDC Clock Frequency <sup>1)</sup>       | $t_{CP}$ | –      | 2.5   | 25.0  | MHz  |   |
| MDC Rise Time                           | $t_R$    | –      | –     | 5.0   | ns   |   |
| MDC Fall Time                           | $t_F$    | –      | –     | 5.0   | ns   |   |
| MDIO Input Setup Time subject to ↑ MDC  | $t_S$    | 10.0   | –     | –     | ns   | Gigabit Ethernet Switch receive   |
| MDIO Input Hold Time subject to ↑ MDC   | $t_H$    | 10.0   | –     | –     | ns   | Gigabit Ethernet Switch receive   |
| MDIO Output Delay Time subject to ↑ MDC | $t_D$    | 0.0    | –     | 10    | ns   | Gigabit Ethernet Switch transmit  |
| <b>Standard at 2.5 MHz</b>              |          |        |       |       |      |   |
| MDIO Output Delay subject to ↑ MDC      | $t_D$    | 0.0    | –     | 300.0 | ns   | PHY transmit  |
| MDIO Output Setup Time subject to ↑ MDC | $t_S$    | 10.0   | –     | –     | ns   | MAC transmit  |
| MDIO Output Hold Time subject to ↑ MDC  | $t_H$    | 10.0   | –     | –     | ns   | MAC transmit  |

1) MDC clock supports range of frequencies, up to 25 MHz. Default/typical frequency is 2.5 MHz.

### 5.5.7 RMI Interface Timing Characteristics

This section describes the AC characteristics of the RMI interface on the Gigabit Ethernet Switch.

This interface conforms to the RMI specification as defined by the RMI Consortium in [2]. **Figure 50** shows the timing diagram of the transmit RMI interface on the Gigabit Ethernet Switch. **Table 81** specifies the timing requirements at 100 Mbit/s.

The values provided in **Table 81** apply as setup and hold timings for all inputs (TXD[1:0], TX\_EN) and as output delay to all outputs (RXD[1:0], CRS\_DV, and RX\_ER) of this interface.

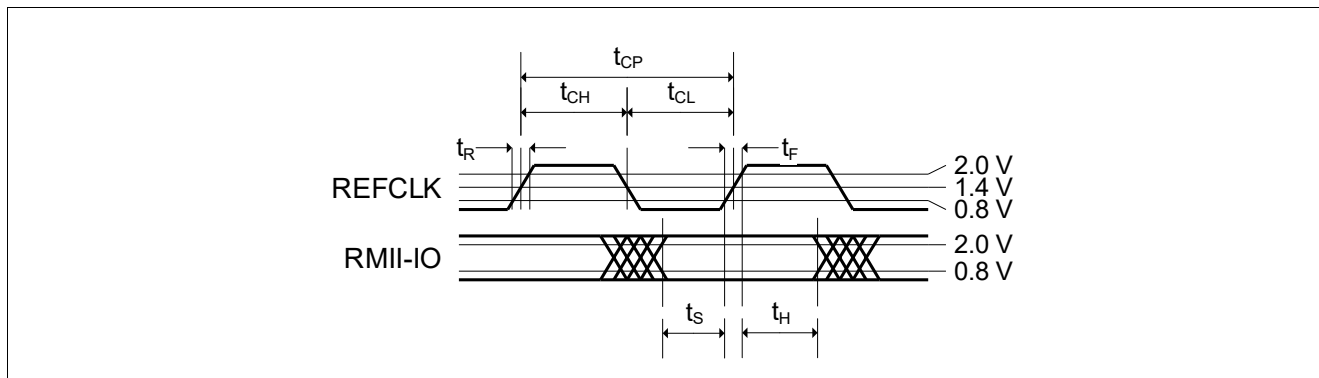

**Figure 50** Transmit/Receive Timing Diagram of the RMI

**Table 81** Timing Characteristics of the RMI at 100 Mbit/s

| Parameter                                      | Symbol              | Values           |       |                  | Unit | Note / Test Condition |
|--|---------------------|------------------|-------|------------------|------|-----------------------|
|  |                     | Min.             | Typ.  | Max.             |      |                       |
| Reference Clock Period                         | $t_{CP}$            | 19.999           | 20.00 | 20.001           | ns   | ±50 ppm               |
| Reference Clock Frequency                      | $F_{REF}$           | 50.00<br>-50 ppm | 50.00 | 50.00<br>+50 ppm | MHz  | ±50 ppm               |
| Reference Clock High Time                      | $t_{CH}$            | 7.00             | 10.00 | 13.00            | ns   | –                     |
| Reference Clock Low Time                       | $t_{CL}$            | 7.00             | 10.00 | 13.00            | ns   | –                     |
| Reference Clock Duty Cycle                     | $D = t_{CH}/t_{CL}$ | 35.00            | 50.00 | 65.00            | %    | –                     |
| Rise Time (Clock and Data)                     | $t_R$               | 1.00             | –     | 5.00             | ns   | –                     |
| Fall Time (Clock and Data)                     | $t_F$               | 1.00             | –     | 5.00             | ns   | –                     |
| Setup Time/Output Delay<br>Subject to ↑ REFCLK | $t_S$               | 4.00             | –     | –                | ns   | –                     |
| Hold Time/Output Delay<br>Subject to ↑ REFCLK  | $t_H$               | 2.00             | –     | –                | ns   | –                     |

### 5.5.8 RGMII Interface Timing Characteristics

The following sections investigate the timing characteristics of the xMII interfaces.

#### 5.5.8.1 RGMII Interface

This section investigates the timing characteristics of the RGMII interface at the Gigabit Ethernet Switch. Unless no HSTL voltages are supported, this interface is conform to the RGMII specification v1.3 and v2.0. The RGMII interface can operate at speeds of 10 Mbps, 100 Mbps and 1000 Mbps.

#### Timing Characteristics

**Figure 51** shows the timing diagram of the RGMII interface at the Gigabit Ethernet Switch. **Table 82** characterizes the timing requirements. The setup and hold times are subject to the internal version of the TX\_CLK/RX\_CLK which is the external clock delayed by the integrated delay and adjustable in steps of 0.5 ns via PCDU register configuration. When the integrated delay is not used, e.g. because its implemented externally by PCB wire delays, it must be set to zero in which case all the timings are related directly to the TX\_CLK/RX\_CLK at the pin.

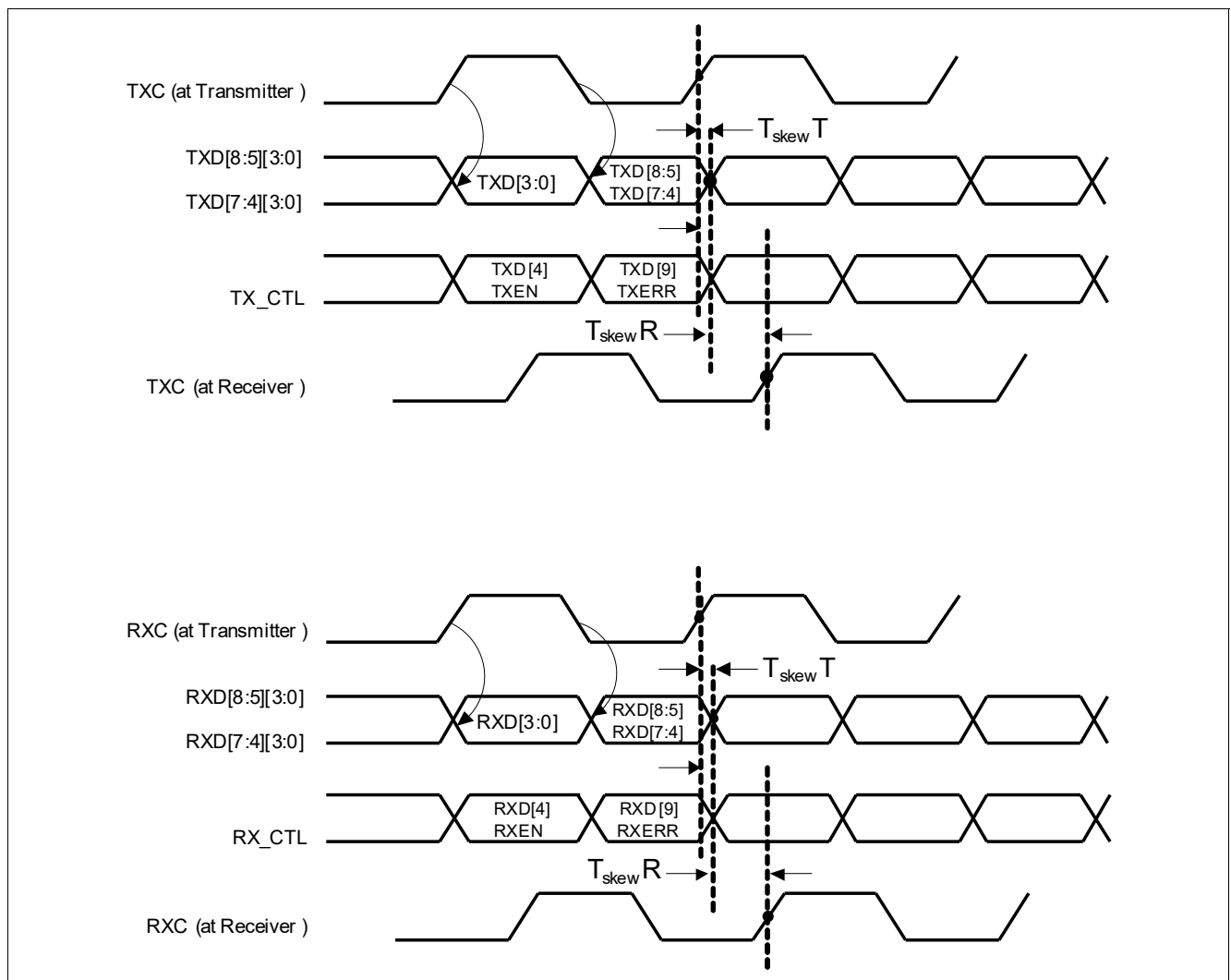

**Figure 51** Timing Diagram of the RGMII

**Table 82 Timing Characteristics of the RGMII**

| Parameter                         | Symbol                   | Values |       |         | Unit | Note / Test Condition    |
|-----------------------------------|--------------------------|--------|-------|---------|------|--------------------------|
|                                   |                          | Min.   | Typ.  | Max.    |      |                          |
| Clock Frequency (RX_CLK/TX_CLK)   | $f_{CLK}$                | -50ppm | 125.0 | + 50ppm | MHz  | For 1000 Mbps speed.     |
|                                   |                          | -50ppm | 25.0  | + 50ppm | MHz  | For 100 Mbps speed.      |
|                                   |                          | -50ppm | 2.5   | + 50ppm | MHz  | For 10 Mbps speed.       |
| Clock Period (RX_CLK/TX_CLK)      | $t_{CP}$                 | 7.2    | 8.0   | 8.8     | ns   | For 1000 Mbps speed.     |
|                                   |                          | 36.0   | 40.0  | 44.0    | ns   | For 100 Mbps speed.      |
|                                   |                          | 360.0  | 400.0 | 440.0   | ns   | For 10 Mbps speed.       |
| Duty Cycle <sup>1)</sup>          | $t_H/t_{CP}, t_L/t_{CP}$ | 45.0   | 50.0  | 55.0    | %    | Speed independent        |
| Clock Rise Time (RX_CLK/TX_CLK)   | $t_R$                    | –      | –     | 750.0   | ps   | 20% → 80%                |
| Clock Fall Time (RX_CLK/TX_CLK)   | $t_F$                    | –      | –     | 750.0   | ps   | 80% → 20%                |
| Clock to Data Skew at Transmitter | $t_{SkewT}$              | -0.5   | 0.0   | 0.5     | ns   |                          |
| Clock to Data Skew at Receiver    | $t_{SkewR}$              | 1      | 1.8   | 2.6     | ns   |                          |
| Integrated Receive Clock Delay    | $t_{ID}$                 | 0.0    | k*0.5 | 3.5     | ns   | Adjustable via registers |

1) Duty Cycle may be stretched/shrunk during speed changes. Such an even last no longer than three  $t_{CP}$  at lowest speed.

### 5.5.8.2 SGMII Interface

This section describes the AC characteristics of the SGMII Interface on the GSW125. This interface conforms to the CEI-6G-SR Specification, as defined in [1]. The SGMII interface can operate at 3.125 Gbaud (maximum). The maximum net data-rate is 2500 Mbps.

#### 5.5.8.2.1 Transmit Timing Characteristics

Figure 52 shows the timing diagram of the transmit SGMII interface at the GSW125. Table 83 specifies the timing requirements.

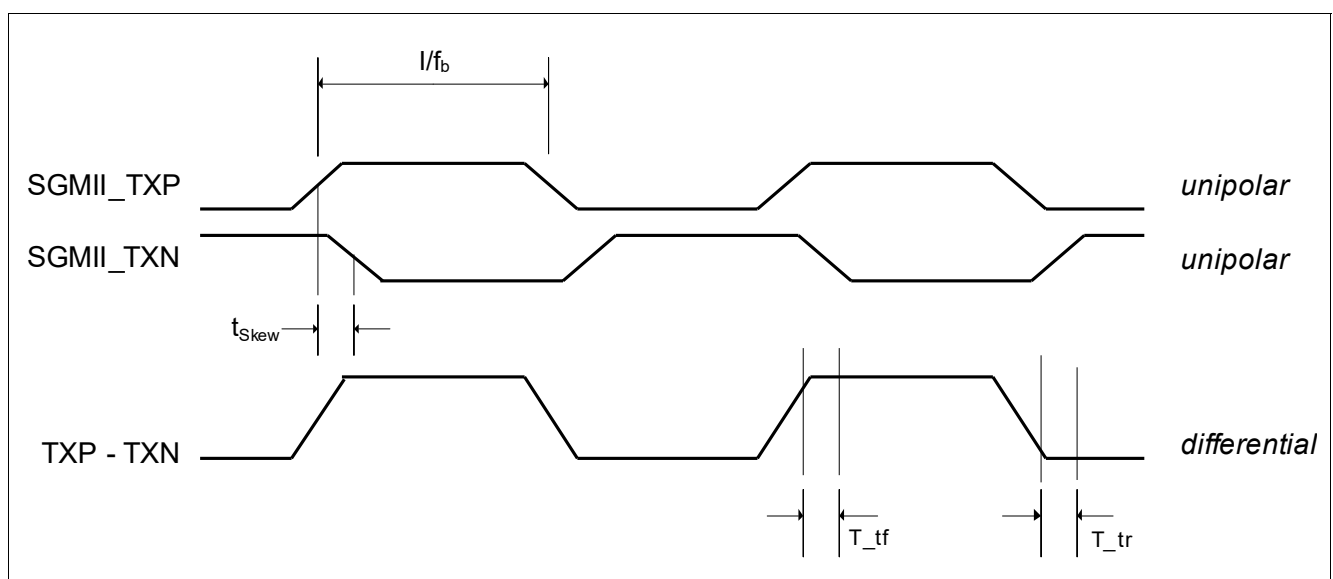
**Figure 52 Transmit Timing Diagram of the SGMII (Shows Alternating Data Sequence)**



**Table 83 Transmit Timing Characteristics of the SGMII**

| Parameter                       | Symbol     | Values   |       |           | Unit             | Note / Test Condition        |
|---------------------------------|------------|----------|-------|-----------|------------------|------------------------------|
|                                 |            | Min.     | Typ.  | Max.      |                  |                              |
| Transmit Baud Rate              | $f_b$      | -100 ppm | $f_b$ | + 100 ppm | Mbaud            | $f_b = 1.25/2.5/3.125$ Gbaud |
| Differential Transmit Rise Time | $T_{tr}$   | 30 ps    | –     | 0.25 UI   | –                | 20% → 80% <sup>1)</sup>      |
| Differential Transmit Fall Time | $T_{rf}$   | 30 ps    | –     | 0.25 UI   | –                | 80% → 20%                    |
| Output Timing Jitter            | $T_{TJ}$   | –        | –     | 0.30      | UI <sub>pp</sub> | 2)                           |
| Time Skew Between Pairs         | $t_{skew}$ | –        | –     | 15        | ps               | –                            |
| Output Differential Voltage     | $V_{OD}$   | 400      | –     | 1600      | mV               | Peak-peak amplitude          |
| Output Impedance (Differential) | $R_O$      | 80       | 100   | 120       | $\Omega$         | –                            |

1)  $UI = 1/f_b$

2) Refer to [1] for details.

### 5.5.8.2.2 Receive Timing Characteristics

Figure 53 shows the timing diagram of the receive SGMII interface on the GSW125. Table 84 specifies the timing requirements.

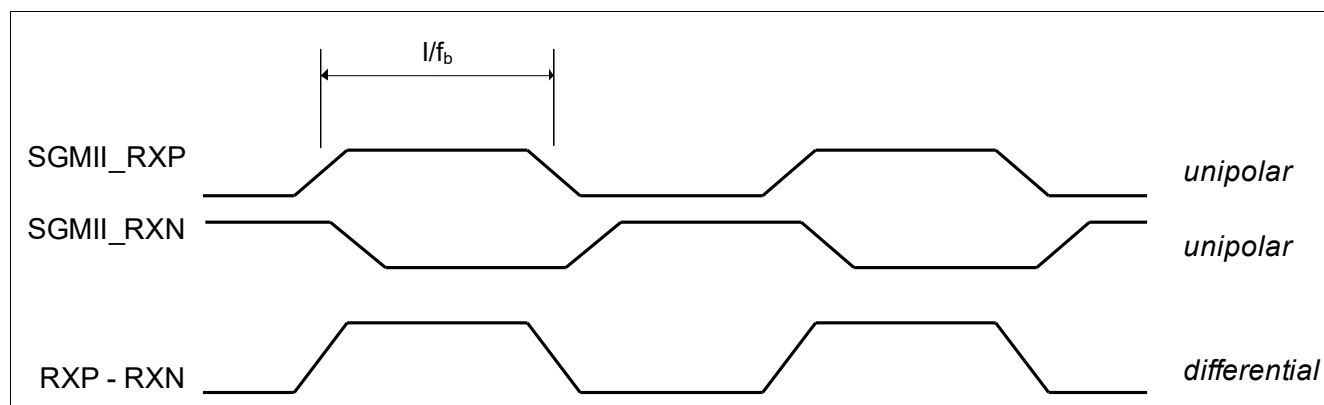
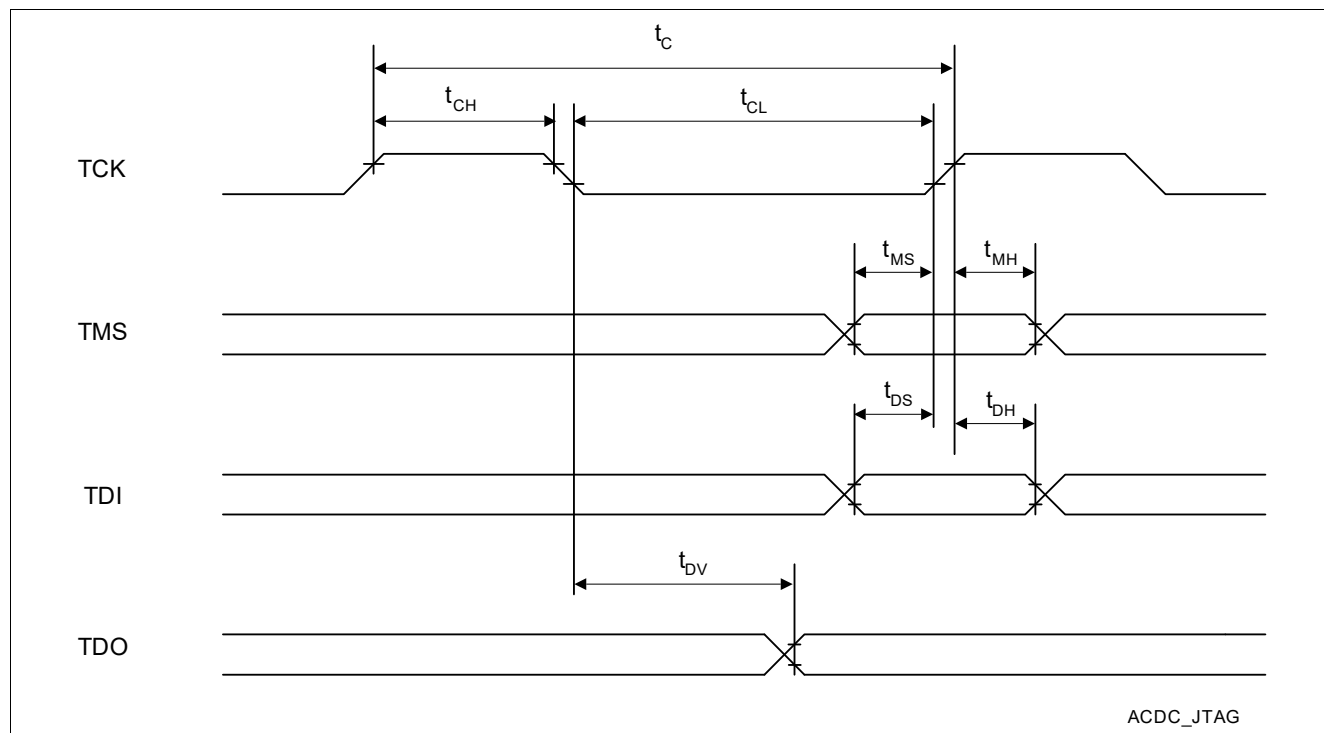

**Figure 53 Receive Timing Diagram of the SGMII (Alternating Data Input Sequence)**
**Table 84 Receive Timing Characteristics of the SGMII**

| Parameter                      | Symbol   | Values   |       |           | Unit                           | Note / Test Condition |
|--------------------------------|----------|----------|-------|-----------|--------------------------------|-----------------------|
|                                |          | Min.     | Typ.  | Max.      |                                |                       |
| Receive Baud Rate              | $f_b$    | -100 ppm | $f_b$ | + 100 ppm | Mbaud                          | $f_b = 1.25$ Gbaud    |
| Receive Data Jitter Tolerance  | $R_{TJ}$ | –        | –     | 0.6       | UI <sub>pp</sub> <sup>1)</sup> | –                     |
| Input Differential Voltage     | $V_{ID}$ | 200      | –     | 1600      | mV                             | peak-peak amplitude   |
| Input Impedance (Differential) | $R_I$    | 80       | 100   | 120       | $\Omega$                       | –                     |

1) Refer to [1] for details.

### 5.5.9 Test Interface

The test interface is used for boundary scan.



**Figure 54 Test Interface Timing**

[Table 85](#) and [Table 86](#) describe the timing values.

**Table 85 Test Interface Clock**

| Parameter        | Symbol   | Values |      |      | Unit | Note / Test Condition |
|------------------|----------|--------|------|------|------|-----------------------|
|                  |          | Min.   | Typ. | Max. |      |                       |
| TCK Clock Period | $t_C$    | 100    | –    | –    | ns   | –                     |
| TCK High Time    | $t_{CH}$ | 40     | –    | –    | ns   | –                     |
| TCK Low Time     | $t_{CL}$ | 40     | –    | –    | ns   | –                     |

**Table 86 JTAG Timing**

| Parameter                         | Symbol   | Values |      |      | Unit | Note / Test Condition |
|-----------------------------------|----------|--------|------|------|------|-----------------------|
|                                   |          | Min.   | Typ. | Max. |      |                       |
| TMS Setup Time                    | $t_{MS}$ | 40     | –    | –    | ns   | –                     |
| TMS Hold Time                     | $t_{MH}$ | 40     | –    | –    | ns   | –                     |
| TDI Setup Time                    | $t_{DS}$ | 40     | –    | –    | ns   | –                     |
| TDI Hold Time                     | $t_{DH}$ | 40     | –    | –    | ns   | –                     |
| Hold: $\overline{TRST}$ After TCK | $t_{HD}$ | 10     | –    | –    | ns   | –                     |
| TDO Valid Delay                   | $t_{DV}$ | –      | –    | 60   | ns   | –                     |

### 5.5.10 Crystal Specification

In the reference design, the crystal is attached to the Gigabit Ethernet Switch SoC and must follow the specifications found in [Table 87](#).

**Table 87** Specification of the Crystal

| Parameter                   | Symbol      | Values |      |      | Unit     | Note / Test Condition   |
|-----------------------------|-------------|--------|------|------|----------|---|
|                             |             | Min.   | Typ. | Max. |          |   |
| Frequency with 25 MHz Input | $f_{clk25}$ | –      | 25.0 | –    | MHz      | –   |
| Frequency with 40 MHz Input | $f_{clk40}$ | –      | 40.0 | –    | MHz      | –   |
| Total Frequency Stability   | –           | -50    | –    | +50  | ppm      | Refer to sum of all effects: eg. general tolerance, aging, temperature dependency |
| Series Resonant Resistance  | –           | –      | –    | 40   | $\Omega$ | –   |
| Drive Level                 | –           | 0.08   | 0.10 | 0.2  | mW       | –   |
| Load Capacitance            | $C_L$       | 16     | -    | 30   | pF       | –   |
| Shunt Capacitance           | $C_0$       | –      | -    | 7    | pF       | –   |

### 5.5.11 Transformers (Magnetics)

GSW125 supports both types of common mode choke on the PHY side or Line side transformer configuration. [Figure 55](#) and [Figure 56](#) show these configurations.

*Note: Refer to the electrical isolation requirement before using the Integrated MagJacks transformer.*

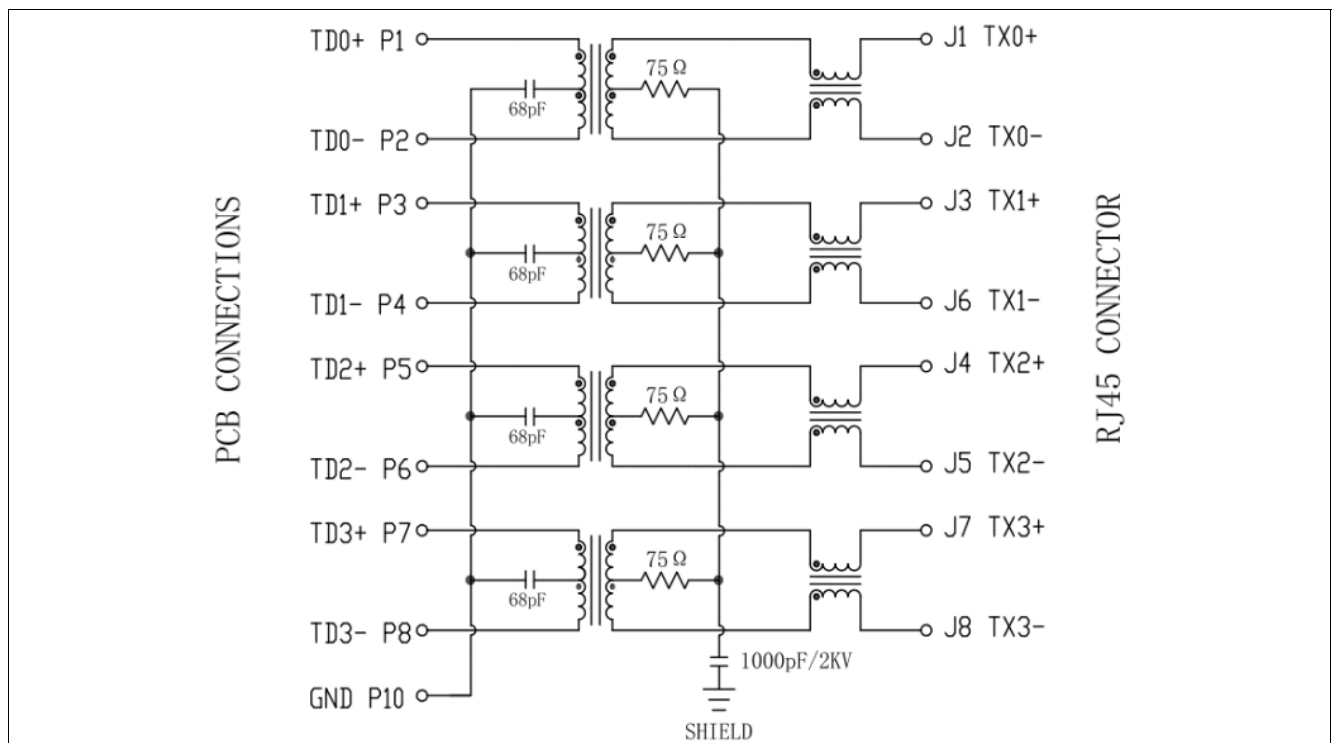

**Figure 55** Schematic of a Transformer with CMC on Line

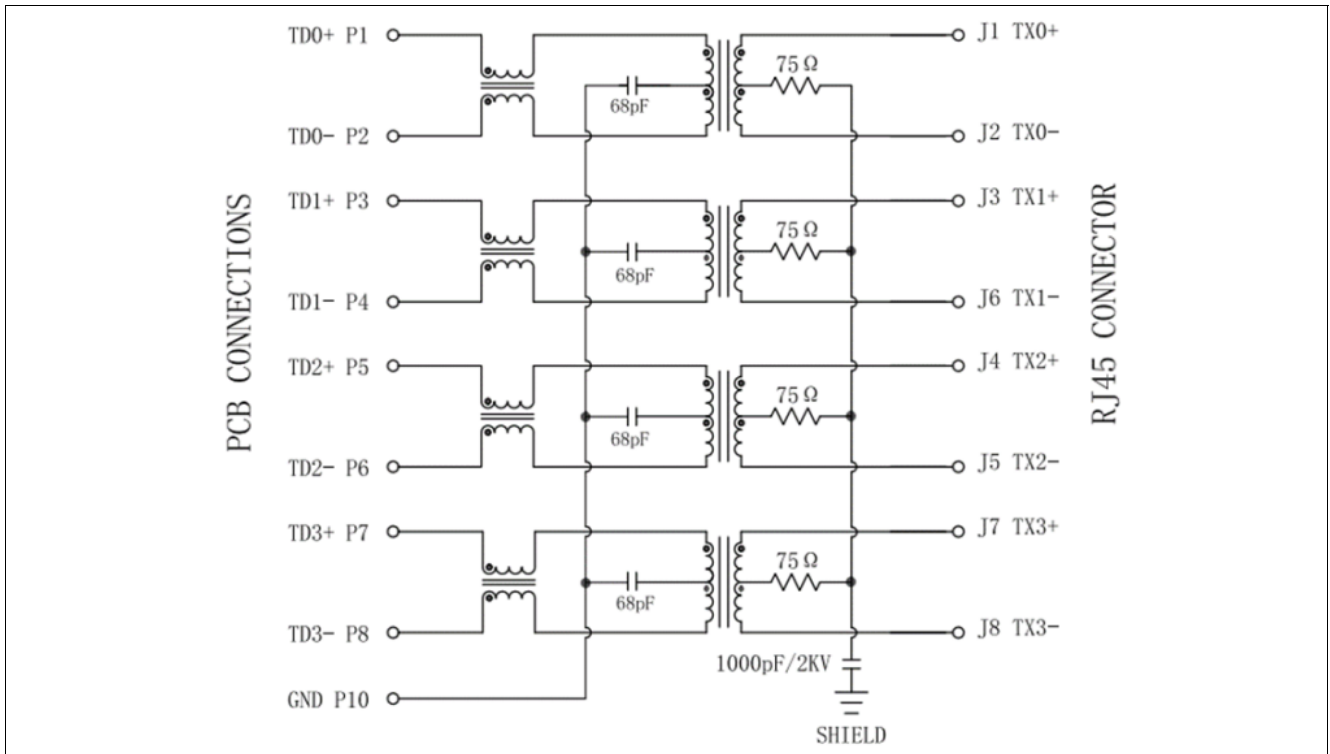

Figure 56 Schematic of a Transformer with CMC on PHY Side

Table 88 specifies the electrical characteristics of the supported transformer devices. The listed specifications guarantee proper operation according to IEEE 802.3.

Table 88 Electrical Characteristics for Supported Transformers (Magnetics)

| Parameter                             | Symbol | Values |      |      | Unit | Note / Test Condition |
|---------------------------------------|--------|--------|------|------|------|-----------------------|
|                                       |        | Min.   | Typ. | Max. |      |                       |
| Turns ratio                           | 1:tr   | 0.95   | 1.00 | 1.05 |      | ±5%                   |
| Differential-to-common-mode rejection | DCMR   | 43     | –    | –    | dB   | 30 MHz                |
|                                       |        | 37     | –    | –    | dB   | 60 MHz                |
|                                       |        | 33     | –    | –    | dB   | 100 MHz               |
| Crosstalk attenuation                 | CTA    | 45     | –    | –    | dB   | 30 MHz                |
|                                       |        | 40     | –    | –    | dB   | 60 MHz                |
|                                       |        | 35     | –    | –    | dB   | 100 MHz               |
| Insertion loss                        | IL     | –      | –    | 1    | dB   | 0.1 MHz ≤ f ≤ 100 MHz |
| Return loss                           | RL     | 18.0   | –    | –    | dB   | 1 MHz ≤ f ≤ 30 MHz    |
|                                       |        | 14.0   | –    | –    | dB   | 31 MHz ≤ f ≤ 40 MHz   |
|                                       |        | 13.0   | –    | –    | dB   | 41 MHz ≤ f ≤ 50 MHz   |
|                                       |        | 12.0   | –    | –    | dB   | 51 MHz ≤ f ≤ 80 MHz   |
|                                       |        | 10.0   | –    | –    | dB   | 81 MHz ≤ f ≤ 100 MHz  |

Note: These characteristics represent the bare minimum for achieving standard performance. Since the transformer significantly impacts the link performance, it is possible to increase the loop reach by selecting transformers with improved parameters.



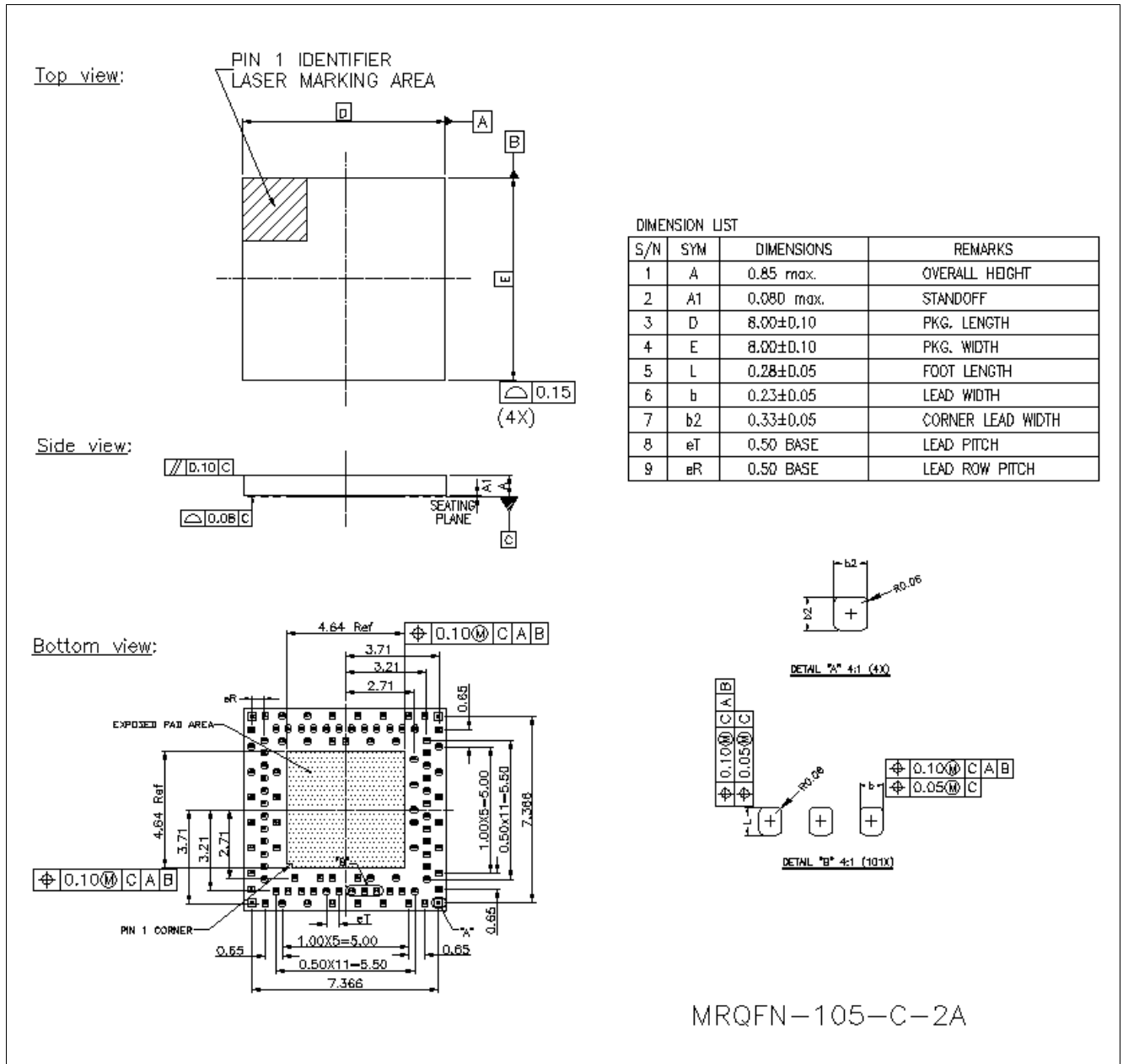

Figure 58 MRQFN 8 mm x 8 mm Package Dimensions

## 6.2 Chip Identification and Ordering Information

**Figure 59** shows an example of the marking pattern on the Gigabit Ethernet Switch (GSW125) device. The actual chip marking may differ slightly from the illustration.



**Figure 59** Example of Chip Marking

**Table 90** explains the chip marking information and **Table 91** provides chip ordering information.

**Table 90** Chip Marking Pattern

| Marking     | Description                                 |
|-------------|---|
| Text Line 1 | MaxLinear Logo                              |
| Text Line 2 | Product Name - See <a href="#">Table 91</a> |
| Text Line 3 | Wafer Lot Number                            |
| Text Line 4 | Date Code (YYWW) and Assembly Site Code (S) |

**Table 91** Product Naming

| Product Name | Ordering Code | Package      |
|--------------|---------------|--------------|
| GSW125       | GSW125-AQM-T  | PG-MRQFN-105 |

## **Standards References**

- [1] Common Electrical I/O (CEI) – Electrical and Jitter Interoperability agreements for 6G+ bps and 11G+ bps I/O (IA # OIF-CEI-02.0) 28th February 2005
- [2] RMI Consortium, RMI-Specification, Rev 1.2, 1997